Thank you for choosing SAIC MAXUS Automotive Co.,Ltd. May our products and services bring fresh joy to your life!

Please take time to read and understand this Handbook and other publications supplied with it. Thus you can familiarize yourself with the vehicle and enjoy a driving experience with comfort, safety as well as economy.

This Driver's Handbook will provide you with the information necessary for getting familiar with your vehicle, including how to drive the vehicle, how to carry out routine maintenance checks, and what to do in an emergency.

This Handbook contains the latest information upon the time of printing and all modifications, interpretations and explanations should be reserved by the company. Based on the consideration that the products will be upgraded or in any other way(s) modified constantly, the company reserves the right to apply these changes mentioned here before without notice when the Handbook has been hereby printed and published and will accept no liability.

This Handbook is an indispensable part of the vehicle. If you want to sell the vehicle, please remember to provide the new owner with this Handbook.

Special Announcement

Driver's Handbook and Warranty & Service Handbook specify the agreement between the company and the user on establishment and termination of rights and obligations concerning the quality warranty and after-sales service of product. Please be sure to read the Driver's Handbook and Warranty & Service Handbook carefully before using the product. If any damage is caused by misuse, neglect, incorrect operation or unauthorized refit, the user will have no right of claim, and any warranty request will be refused by SAIC MAXUS Automotive Co.,Ltd Service Dealer(hereinafter referred to as "Service Dealer").

Unauthorized re-production of this Handbook, whether electrically, physically or in any other way, and/or storing the Handbook in any inquiry system of any form or type shall not be permitted.

Wish you a pleasant driving!

SAIC MAXUS Automotive Co.,Ltd. Address: #2500, Jun Gong Road, Yang Pu District, Shanghai Postcode: 200438

SAIC MAXUS Automotive Co.,Ltd reserves the final right to interpret this Handbook

Contents

Perface	1	Rear side step	19
Introduction	1	Power cargo cover	20
About this handbook	1	Openable rear quarter	21
Precautions	2	Openable rear quarter window control	21
Dangerous substances.....	2	Openable rear quarter unlock to open.....	23
Children/Animals	2	Windows	24
Personal safety.....	2	Power windows	24
Cyber security	2	Power sunroof	26
Vehicle identification	3	Seats	28
Vehicle identification number (VIN)	3	Driver seat adjustment	28
Model and number of drive motor	3	Front occupant seat adjustment	32
VIN plate.....	4	Rear occupant seat adjustment.....	32
Instructions for using electric vehicle	5	Headrest.....	35
Ambient temperature for vehicle use.....	5	Occupant restraint system	36
Driving range	5	Sitting correctly	36
Equalizing charge.....	6	Seat belts	37
Instructions for recycling of high voltage battery packs	6	Seat belt pretensioner	43
High-voltage system.....	7	Airbag(s).....	43
Instructions when accident occurs	8	Child restraints (not available with the vehicle)	53
1 Before You Drive	9	Instruments and controls	62
Keys	10	Instrument cluster	63
Remote key with PEPS	10	High-voltage battery pack quantity meter	63
Extension/retraction of mechanical key portion of the remote key ("mechanical key portion" for short).....	11	Speedometer.....	63
Replace the battery in the remote key with PEPS.....	11	Power meter	63
Door locks	13	Message center.....	64
To protect your vehicle against theft.....	13	Alarm messages.....	66
Central door locking system	13	Maintenance interface reminder.....	67
Tailgate	18	Tire pressure monitoring system	67
		Warning lights and indicators	67

Contents

Direction indicator.....	67	FCW (Forward Collision Warning)/AEB (Automatic Emergency Braking) warning light	73
Headlamp low beam indicator	67	LDW (Lane Departure Warning)/LKA (Lane Keep Assist) /ELK (Emergency Lane Keeping) warning light.....	73
Headlamp high beam indicator.....	67	BSD (Blind Spot Detection)/LCA (Lane Change Assist) warning light	74
IHC (Intelligent High beam Control) indicator	67	ACC (Adaptive Cruise Control) indicators	74
Rear fog lamp indicator	68	ICA (Integrated Cruise Assist) indicators	74
Position lamp indicator	68	SLIF (Speed Limit Information Function) indicators	74
IMMO warning light	68	ISA (Intelligent Speed Limit Assist) indicators	75
TPMS warning light	68	Speed limit indicator	75
Battery charging indicator.....	68	Conditional speed limit indicator.....	75
READY indicator	68	Trailer indicator.....	75
Charging connection indicator.....	69	Driver status monitoring reminder indicator.....	75
Charging status indicator.....	69	Driver status monitor system malfunction indicator.....	76
Power system fault warning light.....	69	Driving mode indicators.....	76
Warning light of high-voltage battery pack for low electric quantity.....	69	Air suspension system indicator.....	76
Insulation fault warning light	69	Air suspension system MIL	77
Power-limit Indicator.....	69	All-terrain system MIL.....	77
Airbag warning light.....	69	CPD OFF indicator light	77
Front passenger airbag warning light	70	Interior discharge indicator	77
Front passenger airbag ON warning light.....	70	CCO (Crawl Control in Off-road) indicator.....	78
Front passenger airbag OFF warning light.....	70	Exterior lamp switch	78
Seat belt warning light.....	70	Combination lamp control switch.....	78
Brake system warning light	71	SOS E-call system switch.....	81
ABS (Anti-lock Braking System) warning light.....	71	Auxiliary fascia console switch.....	81
EBD (Electronic Brake Distribution) warning light	71	Air suspension system switch	81
ESC (Electronic Stability Control) indicator	72	All terrain system switch.....	82
ESC (Electronic Stability Control) OFF indicator.....	72	Switches on steering column and steering wheel	82
EPB (Electronic Parking Brake) indicator.....	72	Wiper and washer lever switches.....	83
EPB (Electronic Parking Brake) malfunction indicator	72		
AUTO HOLD indicator.....	72		
HDC (Hill Descent Control) indicator.....	73		
EPS (Electric Power Steering) system malfunction warning light	73		

Contents

High beam, turn signal lever switch.....	84	Start/stop vehicle.....	114
Instrument cluster selection and cruise switch.....	85	Power on vehicle.....	114
Voice control, bluetooth phone, steering wheel heating and custom settings switch.....	86	Start vehicle.....	114
Horn.....	88	Power off vehicle.....	114
Steering wheel adjustment.....	88	Automatic power off.....	115
Heating, ventilation and air conditioning (HVAC).....	89	Emergency power off.....	115
Front vents.....	89	PEPS system.....	115
Rear vents.....	90	Keyless unlocking.....	115
A/C control switch.....	91	Keyless locking.....	115
A/C operation and display interfaces on center console screen.....	93	Keyless start.....	116
Air conditioning operating tips.....	96	Backup starting.....	116
Rearview mirrors.....	96	Driving.....	117
Exterior rearview mirrors.....	96	Gear shift.....	118
Interior rearview mirrors.....	99	Gear.....	118
Interior equipment.....	102	Shift operation.....	119
Roof vanity lamp.....	102	Auto park (function of automatically returning to P gear).....	121
Multi-color atmosphere light.....	103	Charging requirement.....	121
USB ports.....	104	Requirements for charging equipment.....	122
12V power socket.....	105	Safety instructions for charging with residential electricity.....	122
Wireless charging system for mobile phone.....	105	Requirements for charging environment.....	124
Glove box.....	107	Influence of charging operation on special personnel.....	124
Storage box.....	107	Charging mode.....	125
Sun visor and vanity mirror.....	108	Fast charging.....	126
Vehicle tools.....	109	Slow charging.....	128
Safety hammer.....	109	Charging information.....	132
Entertainment system.....	110	Equalizing charge.....	132
System update (FOTA).....	112	Charging appointment.....	133
2 Starting and Driving.....	113	Charging time.....	133
Before Starting and Driving.....	114	Exterior discharge.....	134

Contents

Discharge requirements	134	Four-wheel drive system	157
Requirements for discharge environment	135	4WD mode switch	157
Discharge operation	135	Crawl control in off-road.....	158
Interior discharge	136	Parking assist system	160
Discharge requirements	136	Front and rear sensors	160
Requirements for discharge environment	137	Rear view camera	161
Discharge operation	137	360°/540° around view system	162
Low speed alarm module	138	Driver assistance system	164
Electric power steering system	139	Camera.....	164
Braking system	140	Radar.....	165
Service brake	140	FCW and AEB (Forward Collision Avoidance Assist)	166
ABS (Anti-lock Braking System).....	142	LDW (Lane Departure Warning).....	169
ESC (Electronic Stability Control).....	143	LKA (Lane Keeping Assist)	171
EPB (Electrical Parking Brake).....	145	ELK (Emergent Lane Keeping)	172
AUTO HOLD	147	ACC (Adaptive Cruise Control)	174
HDC (Hill Descent Control)	148	ICA (Integrated Cruise Assist).....	178
Warning lights.....	149	RCW (Rear Collision Warning).....	181
MCB (Multi Collision Brake)	149	Rear collision avoidance assist	182
Brake pedal sensing mode switching function	149	SLIF (Speed Limit Information Function).....	183
Air suspension system	150	ISA (Intelligent Speed Limit Assistance)	185
Air suspension system height setting	150	IHC (Intelligent High beam Control)	187
Easy loading.....	152	BSD and LCA (Blind Spot Assist).....	189
Vehicle scale	153	RCTA (Rear Cross Traffic Alert).....	191
Welcome mode	153	DOW (Door Open Warning)	192
Camp mode.....	153	Driver state monitoring.....	194
Maintenance mode.....	154	CPD (Child Presence Detection).....	195
Towing mode	154	Tires	196
ATS (All Terrain System).....	154	Winter tires	196
ATS mode switch.....	155	Anti-skid chain	197

Contents

Loading	198	Fuse replacement	222
Load carrying.....	198	Driver compartment fuse box	222
Hazardous loads	198	Front compartment fuse box	225
Load restraint	198	Battery fuse box	228
Cargo box rail/rope hook.....	199	Fuse replacement.....	229
Roof rack and load device.....	200	Bulb replacement	230
Trailer towing	201	4 Maintenance and Service	231
Instructions of trailer towing.....	201	Regular maintenance	232
Trailer control module.....	203	Owner's check	232
Recommended towing weight	204	Daily checks	232
Installation of trailer device.....	205	Weekly checks or check before a long journey	232
Maintenance.....	207	Harsh conditions.....	233
3 Emergency Troubleshooting	209	Front compartment hood	233
Emergency Door Opening or Closing	210	Open front compartment hood	233
Emergency door opening inside the vehicle.....	210	Close front compartment hood	235
Manually unlock and lock the driver door	210	Front compartment hood emergency opening	236
Manually lock the front occupant door and rear doors	211	Front compartment	237
Hazard warning lamp	212	Coolant	238
Warning triangle	212	Check and refill.....	238
Wheel replacement	213	Brake fluid	239
Jack.....	213	Check and refill.....	240
Spare tire.....	213	Washer fluid	240
Replacing tire	215	Check and refill.....	240
Towing a vehicle	218	Wiper blades	241
Towing hitch.....	218	Inspection	241
Towing	219	Replacement of windshield wiper blade	242
Jump start	220	Maintenance	242
Battery disconnection.....	220	Seat belts	243
Jump start.....	220		

Contents

Inspection	243	Wheels and tires	262
Maintenance and service	243	Wheel alignment parameters	263
Battery	244		
Duration of storing the vehicle.....	245		
Operating in winter	245		
Charging the battery with ground equipment	245		
Removing the battery	246		
Replacing the battery	246		
Installing the battery	247		
High voltage battery pack.....	247		
Instructions and restricted conditions	247		
Tires	249		
Tire pressure	249		
Wear indicator	250		
Tire check and rotation	251		
Other maintenance	251		
Vehicle wash	251		
Seat and trim	252		
Door seals	252		
Window glass	252		
Exterior trimming	252		
Anti-corrosion of vehicle	252		
5 General Technical Parameters	255		
Major vehicle dimension parameters	256		
Vehicle weight parameters	257		
Dynamic performance parameters	258		
Main parameters of drive motor	259		
Chassis technical parameters	260		
Recommended fluids.....	261		

Preface

Introduction

About this handbook

This Handbook applies to eTERRON 9 series of pure electric multi-purpose truck.

Caution

IMPORTANT: The information contained in this Handbook is designed to cover more than one model option and variant, and therefore some of the items mentioned here may not apply to your vehicle.

The applicable executive enterprise standard is Q31/011000019C032.

The drawings contained in this Handbook are illustrations for references only.

Indicative information

Warning



This symbol indicates that: In order to avoid the possibility of personal injury or injury to others, relevant procedures must be followed strictly and precisely.

Caution

Caution

Relevant procedures must be followed to avoid the possibility of vehicle damage.

Note

Note: *This is suggestive description which is useful for you.*

Environmental protection



Everyone is obliged to protect the environment. This symbol intends to remind you to pay attention to environmental protection.

Arrows



It represents the described object.



It represents its direction of motion.

See

The contents are referred by the "Section" title.

Preface

Precautions

Dangerous substances

 Many liquids and other substances used in motor vehicles are poisonous and should under no circumstances be consumed and should, so far as possible, be kept away from open wounds. These substances among others include battery acid, coolant, brake fluid, washer fluid, lubricants, refrigerant and various adhesives. Always read carefully the instructions printed on the labels or stamped on components and obey them implicitly. These instructions are for the sake of your health and personal safety. Please treat them with prudence.

For your safety, observe instructions contained in this Handbook.

Children/Animals

 Accidents and injury may be caused by unsupervised children or animals operating controls and switches fitted to your vehicle, or playing with equipment or goods being transported in it.

In order to prevent the accident or personal injury caused by a child or animal, do not leave the child or animal in the vehicle without adult supervision. Also they can become suffocated in hot weather conditions.

Personal safety

 Seat belts are fitted to all seats in your vehicle to reduce the possibility of personal injury in the event of an accident. It is required that all passengers wear a seat belt. In addition, your vehicle has been installed with supplementary restraint system (SRS) comprising an airbag and a seat belt pre-tensioner, providing extra protection for the driver and front passenger.

Please see “Occupant restraint system” in Before You Drive section. Misuse of an air bag can result in injury.

Cyber security

Perform restoration of factory settings and deletion of private data on the entertainment system head unit before vehicle transaction, user change, and vehicle scrapping.

Vehicle identification

When communicating with Our Service Dealer, you should provide the vehicle identification number.

Vehicle identification number (VIN)

Vehicle identification number (VIN) on the vehicle:

- On the right front girder of vehicle, near the rectangular exposed area of the front wheel housing liner (seal position).
- On the VIN plate on the right B pillar.
- On the windshield lower cross member at the left lower corner of the windshield through where the VIN can be seen easily.

This vehicle is equipped with an OBD data link connector, which is located at the lower side of the left instrument cluster. You can contact Our Service Dealer to read VIN information from the electronic control unit of the vehicle with the special device from our company.

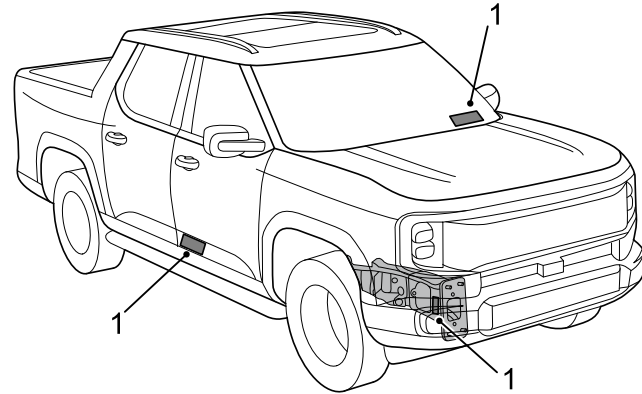

1 Vehicle identification number (VIN)

Model and number of drive motor

The model and number of drive motor are carved on the housing of the drive motor.

Preface

VIN plate

VIN plate may contain the following information, please refer to the actual vehicle.

- The manufacture's company name
- The whole vehicle type-approval number
- VIN
- The technically permissible maximum laden mass
- The technically permissible maximum mass of the combination
- The technically permissible maximum mass on each axle listed in order from front to rear

Location of VIN plate

VIN plate (1) is located at front lower side of right B pillar.

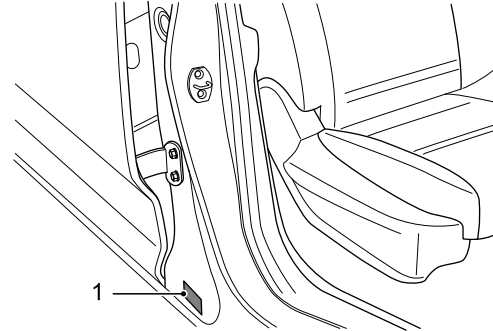

Instructions for using electric vehicle

Ambient temperature for vehicle use

The working performance of the high voltage battery pack in the power system of the vehicle is related to ambient temperature, so it is recommended to use the vehicle at the ambient temperature from -15°C to 45°C, to ensure the vehicle in the best working status and extend the life of the high-voltage battery pack. High or low temperature will affect the performance of the high-voltage battery pack and the vehicle. The working temperature range of the power battery is -30°C to 60°C, and the battery cannot work normally beyond the working temperature range. In the cold weather, it is recommended to store the vehicle in a warm house or park it nearby the charging pile for heating the battery by the connector before use, to avoid affecting traveling.

Driving range

The driving range depends on the available battery level, vehicle age (current battery life), weather, temperature, road conditions, driving habits, etc. Please note:

- The driving range is related to the discharging depth. To avoid affecting the performance of the high voltage battery pack due to high discharging depth, it is recommended that you promptly charge the vehicle after the high voltage battery pack battery level low warning lamp on the instrument cluster in the vehicle gives an alarm.
- The actual driving range of the vehicle is reduced with the increase of the vehicle age.
- The use of A/C will reduce the driving range.
- At different vehicle speeds, the driving ranges are different.
- During the vehicle use at low temperature, the driving range may be reduced due to the temperature characteristics of the battery.
- At extreme temperature and low battery level, the powerless acceleration and power insufficient may occur due to the battery characteristics. The vehicle driving range may be increased by the following methods:
 - Regularly maintain the vehicle.
 - Keep appropriate tire pressure.
 - Minimize the use of the vehicle under high and cold temperature.
 - After using the vehicle in the winter, do not park the vehicle for a long time, and charge it as soon as possible.
 - Remove unnecessary objects to reduce the vehicle load.
 - If necessary, turn off the A/C and other high-power electrical appliances or adjust the heating or cooling temperature to reduce the energy consumed by the high-power electrical appliances and increase the driving range.
 - At high vehicle speed, close the vehicle windows to reduce the air resistance and electricity consumption.

Preface

- Keep the vehicle speed steady.
- In acceleration, step on the accelerator pedal as gently as possible.
- In deceleration, release the accelerator pedal, do not step or gently step the brake pedal, then the energy recycling system will increase the driving range of your vehicle as much as possible.

The standard or dynamic driving range modes may be changed by using the switch on the central control screen, with different values of the driving range, and the latter varies according to your driving habits.

Equalizing charge

Equalizing charging means that during the charging process, under the action of the battery management system, the voltage of each cell is basically the same, so as to ensure the overall performance of the high-voltage battery pack. Therefore, it is recommended to charge the vehicle at least once a month with a slow full charge of less than 25% of its battery capacity to improve battery performance and lifespan.

Instructions for recycling of high voltage battery packs

The high voltage battery pack is installed at the position of motor-vehicle chassis. It contains many lithium battery cells. Arbitrary disposal may cause pollution and hazard to the environment. It is prohibited to disassemble and discard without approval. It will be disposed by professional institution. Be sure to dispose of according to the following information or requirements. Details about recycling and disposal of high voltage battery packs can be obtained through consulting Our Service Dealer.

- Requirements for personnel: be disassembled by the professional personnel with qualifications.
- High voltage safety: make the insulation safety protection before uncovering or disassembling because the battery pack contains the lithium battery pack, high voltage harness, and other high voltage components.
- Transportation: the high voltage pack is the class 9 dangerous goods and must be transported by the vehicle with the class 9 dangerous goods transportation qualifications.
- Storage: the removed high voltage pack shall be stored in a normal temperature and dry environment and kept away from inflammables, heat sources, and water.
- Internal composition: the high voltage pack is composed of lithium battery (pack), circuit board, wires, metal case, and other components.

Preface

It is recommended that you deliver the waste high voltage battery pack produced due to vehicle scrap or other reasons to our designated recycling services for disposal. Details about maintenance, recycling and disposal of high voltage battery packs can be obtained through consulting Our Service Dealer.

Note: The waste high voltage battery pack shall be delivered to other organizations or individuals. If environmental pollution or an safety accident results from the high voltage battery pack removed and disassembled without permission, the owner of the high voltage battery pack shall take the corresponding responsibilities.

High-voltage system



High-voltage system on vehicle includes AC and DC high voltage power (can reach over 380V). High-voltage power is very dangerous and may cause serious injury such as burning, electric shock and even death.

- It is prohibited to contact high-voltage cables and its connectors to avoid personal injury.
- Parts with orange labels are parts of high-voltage system. These parts are equipped with warning label of high-voltage system. Requirements on warning label of high-voltage system must be abided by.
- It is prohibited that non-professional repair personnel contact, disassemble or install any components of high-voltage system without approval.

Instructions when accident occurs



- Keep the vehicle at P gear, turn off the vehicle power.
- If cables on the vehicle are exposed or damaged, it is prohibited to contact any cable to prevent electric shock.
- In case of fire, personnel shall immediately leave the vehicle and use ammonium carbonate salt fire extinguisher to put out the fire or use lots of water to put out the fire. It is strictly prohibited that any person contacts or enters the burning vehicle during the rescue period. After fire has been put out, continuous observation is required. Professional personnel will remove the vehicle to spacious area after confirming power battery does not have abnormal sound and smoke. Professional personnel will confirm battery state before vehicle transfer.
- If the vehicle is collided, the vehicle shall not be re-started. In addition, the negative battery cable will be disconnected when rescuing.
- When vehicle is completely or partially immersed into water, personnel will turn off the vehicle and timely escape. The negative battery cable will be disconnected before transporting vehicle that has been refloated. If there is not bubble or abnormal sound when refloating, refloating operation can

be conducted; if there is bubble or abnormal sound, operation can be conducted when there is not bubble or abnormal sound.

- After accident has been disposed, please contact Our Service Dealer.

Before You Drive

- 10 Keys
 - 13 Door locks
 - 21 Openable rear quarter
 - 24 Windows
 - 28 Seats
 - 36 Occupant restraint system
 - 62 Instruments and controls
 - 63 Instrument cluster
 - 67 Warning lights and indicators
 - 78 Exterior lamp switch
 - 81 SOS E-call system switch
 - 81 Auxiliary fascia console switch
 - 82 Switches on steering column and steering wheel
 - 89 Heating, ventilation and air conditioning (HVAC)
 - 96 Rearview mirrors
 - 102 Interior equipment
 - 110 Entertainment system
 - 112 System update (FOTA)
-

Before You Drive

Keys

The vehicle is equipped 2 remote keys with passive entry passive start system (hereinafter referred to as PEPS).

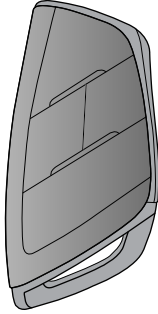

Note: *If a key is lost, you must provide the key number on the plastic plate attached with the key, and the Our Service Dealer will provide the replacement. To ensure safety, you are recommended to keep the plastic plate attached with key properly.*

Note: *For the sake of safety, the key has been electronically coded with the immobilizer system and can be used with the system in the matching way only. Special procedures shall be followed to manufacture a same key with the lost one. Any uncoded key cannot start the vehicle but can lock/unlock doors.*

Remote key with PEPS

The remote key is a control component of central door locking system of a vehicle, which can be used for locking/unlocking all doors.

Note: *The remote key has been electronically coded with the locking/unlocking system and can be used with the system in the matching way only. Special procedures shall be followed to manufacture a same remote key with the lost one. Our Service Dealer will be pleased to assist you.*

See "Central door locking system" in this section for more details about the remote key.

Caution
The immobilizer system can accept 4 coded keys at most (for remote keys with PEPS).

Before You Drive

Extension/retraction of mechanical key portion of the remote key ("mechanical key portion" for short)

Press the release button on the remote key with PEPS, and pull the mechanical key portion from the key body.

To retract the mechanical key portion, directly insert it into the body of remote key with PEPS.

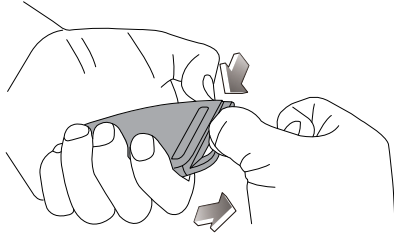

! This product includes coin/button batteries. If the coin/button battery is swallowed, it may cause severe internal burns in just 2 hours and may lead to death. Keep new and used batteries away from children. If the battery cover is not securely closed, please stop using the product and keep it away from children. If you believe that the battery may be swallowed or in any part of your body, please seek medical attention immediately.

Replace the battery in the remote key with PEPS

! Batteries may present the risk of fire, explosion and burning. Never charge the battery. Properly dispose the used battery. Keep the battery out of reach of children.

! **WARNING: Do not ingest the battery, chemical Burn Hazard.**

This product contains coin/button cell battery. If the coin/button cell battery is swallowed, it can cause severe internal burns in just 2 hours and can lead to death. Keep new and used batteries away from children. If the battery compartment does not close securely, stop using the product and keep it away from children. If you think batteries might have been swallowed or placed inside any part of the body, seek immediate medical attention.

WARNING



To replace the battery, following procedures must be observed:

- 1 Press the release button on the remote key with PEPS.

Before You Drive

- 2 Pull the mechanical key portion out of the key body.
- 3 Pry off the upper and lower panels of the body; the circuit board may fall off from the upper panel assembly when prying off them, and reinstall them.

Caution

Do not damage the circuit board when prying off the upper and lower panels.

- 4 Remove the used battery from the lower panel assembly and install a new one.

Note: It is recommended to use a CR2032 battery.

Caution

Pay attention to the positive and negative electrodes of battery.

- 5 Refit the upper and lower panels of the battery body, and press their circumference to ensure they are clamped in place.

Caution

Do not ignore the waterproof shim and circuit board onto the upper panel of the key body.

- 6 Press the mechanical key portion into the key body.

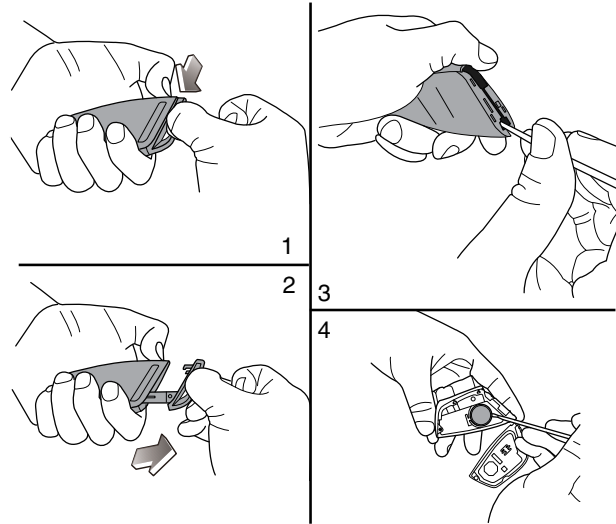

Caution

It is complicated to replace the battery in the remote key with PEPS. In order to prevent the key from being damaged due to misassembly or misoperation, you are recommended to have the battery replaced by Our Service Dealer.

Door locks

To protect your vehicle against theft



When leaving the vehicle with occupants inside, even briefly, always carry the key and power off the vehicle, particularly if children are left in the vehicle. They could otherwise start the vehicle or operate electrical equipment at the risk of causing an accident.

Close all windows before leaving the vehicle. Ensure all doors and front compartment hood are fully closed before locking.

Lock/unlock

You may lock/unlock all doors from outside by using the remote key with PEPS.

All doors can be locked/unlocked from the inside using central lock switch. All doors can be automatically locked according to the vehicle speed. See "Central door locking system" in this section.

Note: When all doors are successfully locked by using the remote key with PEPS, all turn signals will flash once, and the horn will sound once to indicate successful locking. When all doors are successfully unlocked with the remote key, all turn signals will flash twice to indicate successful unlocking.

Central door locking system

Using the mechanical key portion

All doors can be locked/unlocked by manually locking/unlocking the driver door using the mechanical key portion from the outside.

To lock, turn the mechanical key portion clockwise.

To unlock, turn the mechanical key portion counterclockwise.

Using the remote key with PEPS

All doors can be locked/unlocked through the central door locking system using the buttons on the remote key with PEPS.

Note: All doors must be fully closed for the system to operate correctly.

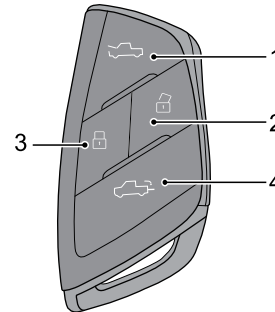

Before You Drive

- 1 Front compartment hood unlock and lock button
- 2 Central unlocking button (short press)/window down (long press)/panoramic sunroof opening (long press) button



Note: For the functions of window down (long press) and panoramic sunroof opening (long press), please refer to your vehicle's actual configuration.

- 3 Central locking button (short press)/window up (long press)/panoramic sunroof closing (long press)

Note: For the functions of window up (long press) and sunroof closing (long press), please refer to your vehicle's actual configuration.

- 4 Tailgate unlock button

Front compartment hood unlock and lock button

Long press the button (1)  to open and close the front compartment hood. During opening and closing, short press the button (1)  to stop the front compartment hood movement, and long press the button (1)  again to reverse the front compartment hood movement.

All doors unlocking

Short press the button (2)  to unlock all doors.

Note: If no door is opened within 30 seconds, all doors will be automatically locked again.

Panoramic sunroof opening

Keep pressing the button (2)  after unlocking; if the panoramic sunroof is closed, the sunshade will be opened to the half-open position first, and then the panoramic sunroof glass will be opened to a comfortable position. The maximum time for long press is 15 seconds.

Note: For the function of panoramic sunroof opening by long pressing the button (2) , please refer to your vehicle's actual configuration.

All doors locking

Short press the button (3)  to lock all doors, provided that all doors have been closed.

Note: All turn signals flashing once represents the confirmation for locking; if the driver door is not closed, the lock motor will not operate; if any door other than the driver door or the front compartment hood is not fully closed, the lock motor will operate, and there will be no audible alarm. Please close all doors and the front compartment hood before pressing the button (3) .

Panoramic sunroof closing

Keep pressing the button (3)  after locking; if the panoramic sunroof is open, the panoramic sunroof glass will automatically close. The maximum time for long press is 15 seconds. If the

Before You Drive

sunroof glass and guide rail suffer from snow or dirt, they should be cleaned immediately before long pressing the button (3) .

Note: For the function of panoramic sunroof closing by long pressing the button (3) , please refer to your vehicle's actual configuration.

Tailgate unlock button

Long press the button (4)  to unlock the tailgate. After unlocking the tailgate, it can automatically and slowly open to the maximum angle.

Using the micro switch

PEPS system allows you to lock or unlock the doors without taking the remote key with PEPS out of your pocket, wallet, or suitcase.

Unlock with the remote key with PEPS

As long as there is a legitimate remote key with PEPS existing within 1 meter around the vehicle, short press the micro door switch on the door handle, and the door will be unlocked.

Note: The key supports anti keyless entry system attacks. After the key stops moving for 1 minute, the key does not support this function and needs to be shaken to restore the function.

Lock with the remote key with PEPS

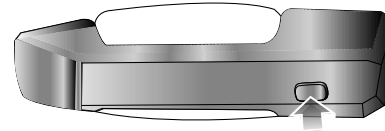

After powering off, leaving the vehicle and closing the door, long press the micro door switch on the door handle with your thumb to lock the door, without pressing the lock button on the remote key with PEPS, but the prerequisite is that all doors are closed.



Note: The key supports anti keyless entry system attacks. After the key stops moving for 1 minute, the key does not support this function and needs to be shaken to restore the function.

Caution

After unlocking, the door needs to be opened within 5s. If the door cannot be opened after 5s, you can press the micro door switch on the door handle again or pull the outer door handle to open the door. Press the inner/outer door switch for 8 consecutive times within 10s to perform the electric release operation, and the inner/outer electric release function will be deactivated for 15s.

Before You Drive

Using the central lock switch

All doors can be unlocked or locked from the inside using the switch. Press the unlocking button (1)  to unlock all doors. Press the locking button (2)  to lock all doors.

Note: *If driver door is not closed, the lock motor will not operate. If the driver door is closed and any other door is not closed, the lock motor will operate.*



In the locked state of the vehicle, press the interior door switch twice on the door to open the current door. In the unlocked state of the vehicle, press the interior door switch once on the door to open the current door.

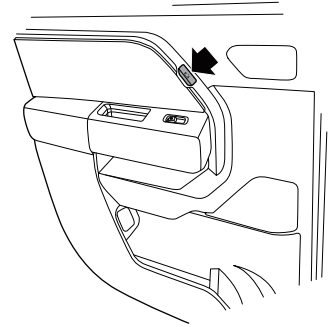

Note: *During the driving, all doors shall be fully closed and all door locks shall be enabled, so as to avoid accidental opening of doors. When the vehicle is in a non-stationary state, please do not actively touch the inner/outer door switch of the vehicle, so as to avoid damage to the personnel and the vehicle when opening the door.*

Caution

After unlocking, the door needs to be opened within 5s. If the door cannot be opened after 5s, you can press the micro door switch on the door handle again or pull the outer door handle to open the door. Press the inner/outer door switch for 8 consecutive times within 10s to perform the electric release operation, and the inner/outer electric release function will be deactivated for 15s.

Before You Drive

Emergency door opening inside the vehicle

Open the emergency door pull ring cover located below the vehicle door, pull the pull ring once to open the door.

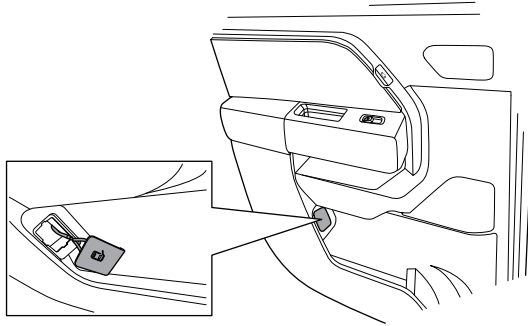

Caution

When the child lock is in the locked state, both the door opening switch and the emergency door pull ring cannot open the door from the inside.

Locking according to the vehicle speed

When the vehicle speed exceeds 8 km/h, all doors can be locked automatically under this function.

Note: When the vehicle is powered off, the doors will automatically unlock.

Electronic child safety door lock

Caution

When children are sitting in the rear seats, please use electronic child safety door locks.

The electronic child safety door lock control switch is located on the central control screen and can respectively control the opening and closing of the child safety door locks on the left and right rear doors. Set up in the central control screen: Settings ->Vehicle ->Doors & Window ->Left child lock/Right child lock.

Caution

When the electronic child safety door lock is in the locked state, Neither the inner door switch nor the interior emergency cable can open the door from inside. In this case, the door can be opened by operating the outer handle from outside.

Before You Drive

Tailgate

After unlocking the vehicle, short press the tailgate switch on the left upper end of the tailgate to unlock it. After unlocking the tailgate, it can automatically and slowly open to the maximum angle. When closing, flip the tailgate into the lock.

When the vehicle is locked, the opening of the tailgate can be realized through the following paths:

- 1 Unlock the vehicle first, and then open the tailgate according to the methods mentioned above.
- 2 Or open the tailgate by long pressing the tailgate unlock button on the key.

Tailgate switch without air suspension system

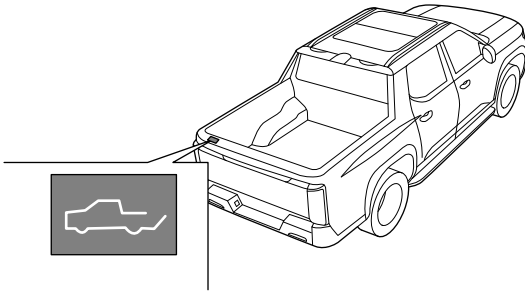

Tailgate switch for configuring air suspension system

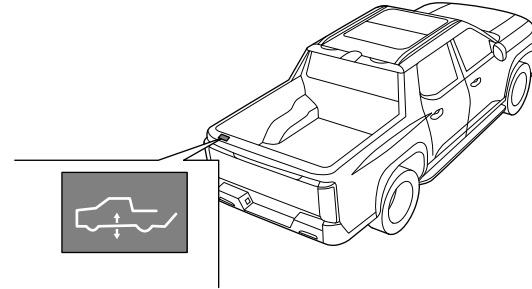

Note: The tailgate switch can activate the air suspension easy loading function, please see "Air suspension system" in the Starting and Driving section.

Note: During the driving, the tailgate shall be fully closed, so as to avoid accidental opening of tailgate.

Before You Drive

Rear side step

Note: It applies to vehicles configured with the rear side step.

The rear side step is located under the left rear bumper of the vehicle.

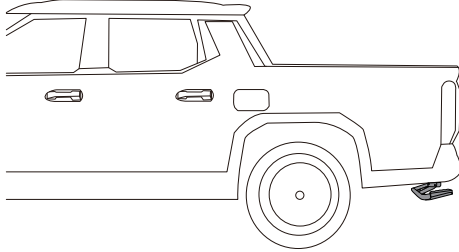

Step on the side features of the step from the side and rear of the vehicle, and step down towards the rear of the vehicle to extend the step.

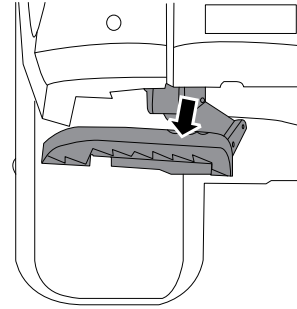
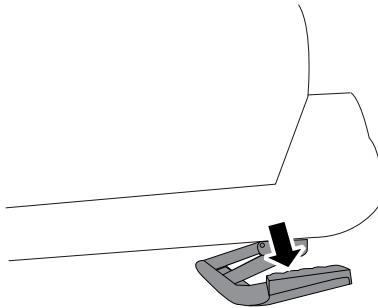

Push the edge of the step toward the front of the vehicle from the rear side of the vehicle to retract the step.

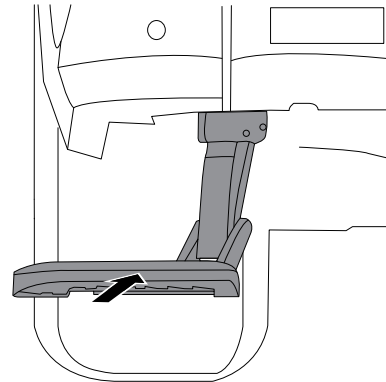

! The rear side step needs to be retracted after use.
Avoid scuffing while the vehicle is in motion.

Before You Drive

Power cargo cover

Note: It applies to vehicles configured with the power cargo cover.

When the vehicle is unlocked and the speed is not greater than 3km/h, you can control the opening/closing of the power cargo cover with the tailgate switch (1).

Short press the switch (1) to control the power cargo cover to open/close automatically to the limit position. During the movement of the power cargo cover, pressing the switch (1) will stop the roller shutter from moving. Pressing the switch (1) again will cause the roller shutter to move in the opposite direction.

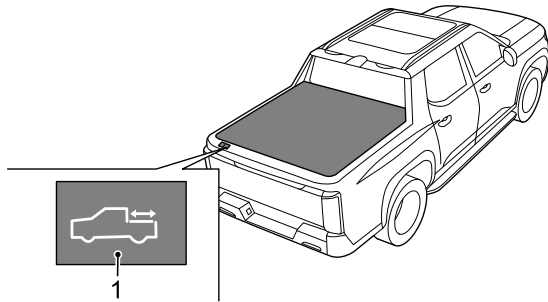

When the power cargo cover is open, the LED lamp in the power cargo cover will come on, then go out after there is no action for consecutive 5 minutes. When the switch is operated again to perform the opening or closing action, the LED light will come on. When the power cargo cover is fully closed, the LED lamp

goes out. When the vehicle is locked or powered off, the LED lamp goes out immediately whether the power cargo cover is open or not.

When the vehicle has been inactive for a long time and has entered the dormant state, pressing the switch (1) can activate the vehicle and achieve the purpose of operating the power cargo cover.

Caution

When the power cargo cover is in motion, it will stop moving when an obstacle is encountered, if you need to resume, remove the obstacle and operate the switch (1) again. Do not press the switch repeatedly in a short period of time (more than 8 times in 30 seconds), it will trigger the anti-play protection of the power cargo cover, the power cargo cover will stop working, and will resume after there is no action in 30 seconds.

Caution

The surface of the power cargo cover should not be maliciously stepped on or stored with heavy objects. Poor use may cause damage to the internal mechanism, abnormal operation, and reduce the service life.

Self-learning of the power cargo cover

If there is a power outage or other abnormal situation during the use of the vehicle, resulting in the power cargo cover not responding or unable to switch in place when pressing the switch (1), you can try to perform self-learning of the power cargo cover to restore its function. The method is as follows: reconnect the power supply, long press the switch (1) until the rolling shutter moves to the end in the closing direction, and then release the hand. At this time, you can complete one self-learning.

Openable rear quarter

Note: It applies to vehicles configured with the openable rear quarter.

1

Openable rear quarter window control

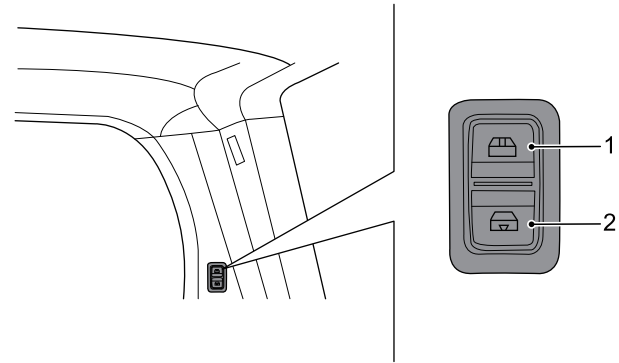

- 1 Rear quarter window closing button
- 2 Rear quarter window opening button

Press the button (1) to close the corresponding rear quarter window, and press the button (2) to open the corresponding rear quarter window.

Note: The rear quarter windows can be operated only when the vehicle is powered on.

Before You Drive

Note: *Please correctly operate the windows to avoid danger. The driver shall instruct passengers how to use rear quarter windows and tell them safety precautions.*

Rear quarter window auto up/down function

"One-touch" down

Short press the rear quarter window opening button (2), the rear quarter window will be lowered by one-touch, and the window is automatically lowered and opened. During the lowering of the rear quarter window, operate the button again to stop the window lowering.

"One-touch" Up and "Anti-pinch"

Short press the rear quarter window closing button (1), the rear quarter window will be raised by one-touch, and the window is automatically raised and closed. During the raising of the rear quarter window, operate the button again to stop the window raising.

The "anti-pinch" function is a safety feature, which enables the rear quarter window to stop raising when it senses an obstacle. If this occurs, the rear quarter window will be automatically lowered a certain distance so that the obstacle can be removed.

Rear quarter window Tap up/down function

"Tap" down: long press the rear quarter window opening button (2), the rear quarter window will be lowered, release the button, and the window stops moving.

"Tap" up: long press the rear quarter window closing button (1), the rear quarter window will be raised, release the button, and the window stops moving.

Rear quarter window control on center console screen

The up/down and closing of the rear quarter window can be controlled with the rear quarter window buttons on the center console screen. Set on the center console screen: Settings->Vehicle->Door & window lock->Rear quarter window, you can perform "fully open", "pause" and "fully close" operations for the rear quarter window.

Before You Drive

Openable rear quarter unlock to open

Fold down the rear occupant seats before opening the rear quarter, see "Rear occupant seat adjustment" in this section for the folding and adjustment methods of the rear occupant seats.

! It is prohibited to open the rear quarter while the vehicle is in motion. It is prohibited to allow any person to stay on the rear quarter while the vehicle is in motion. It is prohibited to allow any person to enter or exit the cargo area through the opened rear quarter while the vehicle is in motion.

Caution

After the rear quarter is fully opened, the maximum load on it must not exceed 120kg.

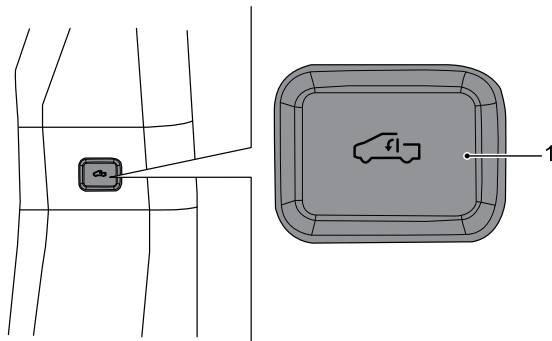

Short press the rear quarter unlock button (1), the rear quarter window will be automatically lowered to the fully open position, and the rear quarter will be unlocked.

Note: After the rear quarter is unlocked, please pull the rear quarter to the open position as soon as possible. If the rear quarter is not opened within 5 seconds, the rear quarter lock will be locked automatically, if you still need to open the rear quarter, you must press the rear quarter unlock button (1) again.

Rear quarter unlocking control on center console screen

The rear quarter can be unlocked with the rear quarter opening button on the center console screen. Set on the center console screen: Settings->Vehicle->Door & window lock-> Rear quarter opening, you can perform "unlock" operation for the rear quarter.

Emergency unlocking of the rear quarter

The rear quarter is equipped with the emergency unlocking function. When the rear quarter cannot be opened by the rear quarter unlocking button, the emergency unlocking paddle of the rear quarter can be pivoted to the right with a driver or a screwdriver to realize the emergency unlocking.

Before You Drive

Windows

! It is dangerous to leave children, incapacitated adults or pets on the vehicle with windows closed. They may faint out due to high temperature, or suffer permanent injury or even death due to heat stroke. Do not leave children, incapacitated adults or pets on the vehicle with the windows closed, especially in the warm or hot weather.

Power windows

! Always take care when operating the power window. There is a risk of injury, especially for children. Please pay close attention when closing the window. Ensure that no objects are stuck in it while the window is moving.

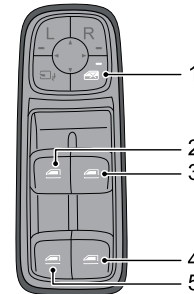
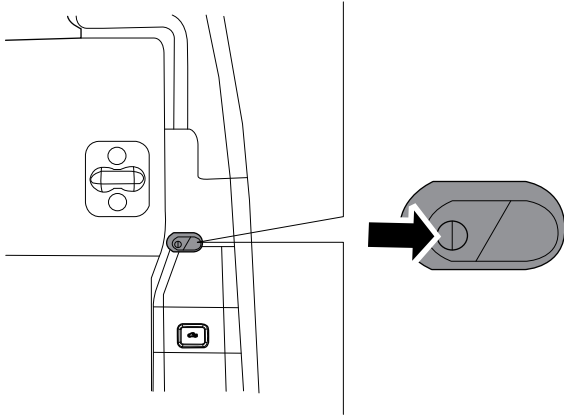

- 1 Rear window disable switch
- 2 Left front door window control switch
- 3 Right front door window control switch
- 4 Right rear door window control switch
- 5 Left rear door window control switch

Press the switches (2) to (5) , to lower the window glass; lift the switch, to move the window glass up. Release the switch, and the window stops working (except for "One-button" mode).

Note: The front door and rear door windows can also be controlled by using the window switch on each door. If the rear window disable switch on driver door is activated, the window control switch on the rear door does not work.

Rear window disable switch

Press the switch (1)  to disable the window control (the indicator on the switch illuminates at this time), and press the switch again to resume the control.

Note: When a child sits on the rear seat, the disable function shall be enabled.

Note: The power window can operate only when the vehicle is powered on. Please operate the windows correctly to avoid danger, and the driver should provide guidance on usage of windows and safety precautions.

Automatic up/down function of window

"One-button" down

Window control switches (2) to (5)  have two positions, short press to the second position, and the window automatically opens. During the window glass down process, operate the switch again to stop the window glass moving down.

"One-button" up and "Anti-pinch"

The left front door window has "One-button" up function; briefly lift the window control switch (2)  to the second position, and the window glass automatically moves up to close; operate the switch again to stop the movement of window glass at any time.

"Anti-pinch" function is a kind of safety function, which can allow the window glass to stop moving up when obstacles are sensed. If this situation occurs, the window glass will automatically moves down to take out obstacles.

The right front door window and rear door window of some models also have "One-button" up and "Anti-pinch" functions, whose operation methods are the same as those of left front window.

Resume the automatic up/down function

If the vehicle battery cable is re-connected after the disconnection, or the battery was drained once, or the anti-pinch function has been enabled for 3 consecutive times at the same position when the window glass moves up, the automatic

Before You Drive

up/down function may not work, it must be re-learned to restore the function. Close all doors, pull up the window up/down switch, until the window is fully closed, hold the switch for about several seconds after the window is fully closed; then press the window up/down switch until the window is fully open, hold the switch for about several seconds after the window is fully open, the automatic up/down function will be recovered.

Power sunroof

Note: *It applies to vehicles configured with the power sunroof.*

Instructions



Do not allow occupants to extend any part of their bodies out of the sunroof while driving - to avoid injuries caused by flying objects or tree branches.

- Do not open the sunroof in rainy day. When the vehicle speed is more than 120km/h, it's better not to open the sunroof.
- Remove the accumulated water from the sunroof glass before opening the sunroof, otherwise water drop may slide off when the sunroof is opened. Use cleaner like alcohol to clean the glass.
- After operation on the sunroof is completed, please release the sunroof operation switch in time, otherwise it may cause failure.
- To ensure normal operation of sunroof, please clean the sunroof frequently and go to Our Service Dealer for sunroof maintenance according to the maintenance requirements.



When operating the sunroof, be sure to keep persons in the vehicle safe, especially children; do not put any part of body or objects into the sunroof, to prevent being pinched by the sunroof.

Note: The power window can operate only when the vehicle is powered on.

Operation method of sunroof

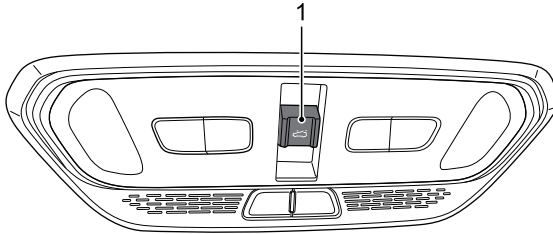

Press the sunroof opening button (1) once, and the sunroof will be lifted to the position for ventilation.

The sunroof will be opened manually when the button (1) is pushed toward the rear of the vehicle by one gear; the sunroof will slide to the fully open position when the button (1) is pushed toward the rear of the vehicle by two gears.

The sunroof will be closed manually when the button (1) is pushed toward the front of the vehicle by one gear; the sunroof will slide to the fully closed position when the button (1) is pushed toward the front of the vehicle by two gears.

During the automatic operation, the button (1) can be pressed once, to make the sunroof stop at the required position.

The sunshade opening switch (2) and closing switch (3) have jog and automatic functions, which can easily control the opening and closing process of the sunshade. Short press the switch (2) or (3) to open or close the sunshade in jog mode; long press the switch (2) or (3) to automatically open or close the sunshade.

Sunroof initialization

With the sunroof glass fully open and the sunshade fully open, press and hold the button (1) for more than 10 seconds toward the front of the vehicle, at this time, the sunroof glass and the sunshade will move toward the opening direction, then move toward the closing direction after reaching a certain position. Continue to press and hold the button (1) until the sunroof glass and the sunshade are fully closed, then release the switch again, thus the initialization operation of the sunroof has been completed.

Note: During the initialization process, if you inadvertently release the button (1), resulting in the loss of automatic opening and closing function of the sunroof, just repeat the initialization operation and it will return to normal after completion. If repeated operations still fail to restore the sunroof, please contact Our Service Dealer for service.

Before You Drive

Seats

Driver seat adjustment

! Do not adjust the driver seat while the vehicle is in motion. If you do at that time, the vehicle may be out of control and cause an accident.

Manually adjusted driver seat

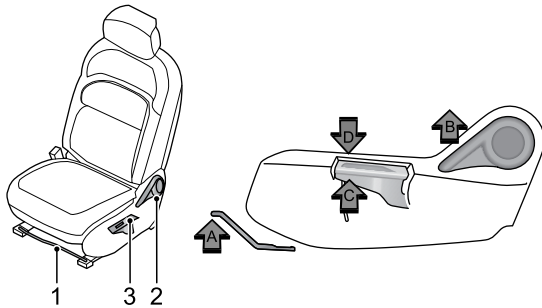

Forward/backward sliding

When the adjuster (1) is pushed up (arrow A), the track will be unlocked, and the seat can be moved forward and backward. When the seat slides to the desired position, release the adjuster (1) to stop the seat sliding.

Rake adjustment of backrest

! Do not recline the seat excessively as the seat belt provides maximum protection only when the angle between the backrest and the upright position is near 25°.

When the angle adjustment armrest (2) is pushed up (arrow B), the backrest is unlocked and can tilt forward and backward. When the seat backrest tilts to the desired position, release the angle adjustment armrest (2) to stop the backrest tilting.

Cushion height adjustment

When the front end of the height adjustment armrest (3) is pushed up (arrow C), the cushion will move upward. When the cushion rises to the desired position, release the height adjustment armrest (3) to stop the cushion movement.

When the front end of the height adjustment armrest (3) is pushed down (arrow D), the cushion will move downward. When the cushion falls to the desired position, release the height adjustment armrest (3) to stop the cushion movement.

Electrically adjustable driver seat (type 1)

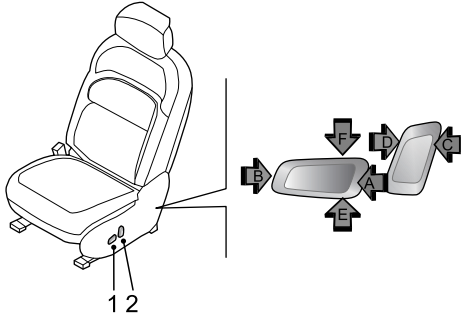

Caution

The seat can be freely adjusted whether the vehicle is powered on or not. But the electrical adjustment will consume the battery power of the vehicle and may drain the battery.

Forward/backward sliding

When the button (1) is toggled forward (arrow A), the seat will move forward. When the seat slides to the desired position, release the button (1) and the seat will stop sliding.

When the button (1) is toggled backward (arrow B), the seat will move backward. When the seat slides to the desired position, release the button (1) and the seat will stop sliding.

Cushion height adjustment

When the rear end of button (1) is toggled upward (arrow E), the seat cushion will move upward. When the seat cushion reaches the desired position, release the button (1) and the cushion will stop moving.

When the rear end of button (1) is toggled downward (arrow F), the seat cushion will move downward. When the seat cushion reaches the desired position, release the button (1) and the cushion will stop moving.

Backrest tilt adjustment

! The tilt angle of the seat should not be too large. The seat belt can provide maximum protection only when the backrest of the seat is approximately 25° from the vertical direction.

When the button (2) is twisted forward (arrow C), the backrest will rotate forward. When the backrest is rotated to the desired position, release the button (2) and the backrest will stop rotating.

When the button (2) is twisted backward (arrow D), the backrest will rotate backward. When the backrest is rotated to the desired position, release the button (2) and the backrest will stop rotating.

Before You Drive

Electrically adjustable driver seat (type 2)

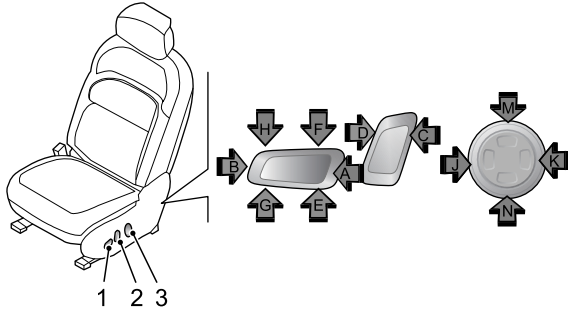

Caution

The seat can be freely adjusted whether the vehicle is powered on or not. But the electrical adjustment will consume the battery power of the vehicle and may drain the battery.

Forward/backward sliding

When the button (1) is toggled forward (arrow A), the seat will move forward. When the seat slides to the desired position, release the button (1) and the seat will stop sliding.

When the button (1) is toggled backward (arrow B), the seat will move backward. When the seat slides to the desired position, release the button (1) and the seat will stop sliding.

Cushion height adjustment

When the rear end of button (1) is toggled upward (arrow E), the seat cushion will move upward. When the seat cushion reaches the desired position, release the button (1) and the cushion will stop moving.

When the rear end of button (1) is toggled downward (arrow F), the seat cushion will move downward. When the seat cushion reaches the desired position, release the button (1) and the cushion will stop moving.

Rake adjustment of cushion

When the front end of the button (1) is pushed up (arrow G), the front end of the cushion will move upward while the upper end of the backrest tilts backward, and when the cushion tilts to the desired position, release the button (1) to stop the cushion movement.

When the front end of the button (1) is pushed down (arrow H), the front end of the cushion will move downward while the upper end of the backrest tilts forward, and when the cushion tilts to the desired position, release the button (1) to stop the cushion movement.

Backrest tilt adjustment

⚠ The tilt angle of the driver seat should not be too large. The seat belt can provide maximum protection only when the backrest is approximately 25° from the vertical direction.

When the button (2) is twisted forward (arrow C), the backrest will rotate forward. When the backrest is rotated to the desired position, release the button (2) and the backrest will stop rotating.

When the button (2) is twisted backward (arrow D), the backrest will rotate backward. When the backrest is rotated to the desired position, release the button (2) and the backrest will stop rotating.

Lumbar support adjustment

When pressing and holding the front end of button (3) (arrow J), the lumbar support will move forward. When the lumbar support moves to the desired position, release the button and the lumbar support will stop moving.

When pressing and holding the rear end of button (3) (arrow K), the lumbar support will move backward. When the lumbar support moves to the desired position, release the button and the lumbar support will stop moving.

When pressing and holding the upper end of button (3) (arrow M), the lumbar support will move upward. When the lumbar support moves to the desired position, release the button and the lumbar support will stop moving.

When pressing and holding the lower end of button (3) (arrow N), the lumbar support will move downward. When the lumbar support moves to the desired position, release the button and the lumbar support will stop moving.

Memory position function

The seat memory position function has 3 levels. When entering the seat interface in the vehicle settings on the central control screen, first adjust the seat (backrest/sliding forward or backward/front height adjustment/rear lifting function) to the desired position, select the driver's memory touch button 1/2/3, and press and hold for about 2 seconds, the central control screen will prompt a successful save (if we adjust the position to a position other than memory 1, we can short press memory button 1 to restore it to memory 1, and the seat will move to the storage position of memory 1).

Heating function

The seat heating function has 3 levels. Enter the seat interface in the vehicle settings on the central control screen, select the driver seat heating touch button, and follow the prompts to adjust.

Ventilation function

The seat ventilation (blowing) function has 3 levels. Enter the seat interface in the vehicle settings on the central control screen, select the driver seat ventilation touch button, and follow the prompts to adjust.

Note: The seat cushion heating function and ventilation function cannot be used simultaneously.

Before You Drive

Front occupant seat adjustment

Manually adjustable front occupant seat

Only forward/backward sliding and seat backrest tilt adjustment can be performed, and its adjustment method is consistent with that of the manually adjusted driver seat.

Electrically adjustable front occupant seat

Only forward/backward sliding, seat backrest tilt adjustment and cushion height adjustment can be performed, and its adjustment method is consistent with that of the electrically adjustable driver seat (type 1).

For the front occupant seat equipped with heating function, enter the seat interface in the vehicle settings on the central control screen, select the front occupant seat heating touch button, and adjust according to the prompts.

Rear occupant seat adjustment

 **It is prohibited to turn over the seat cushion while the vehicle is in motion. It is prohibited to fold the backrest while the vehicle is in motion.**

It is prohibited for anyone to sit on the turned-over seat cushion while the vehicle is in motion. It is prohibited for anyone to sit on the folded backrest or in the luggage area.

Do not allow children to enter the luggage area.

Caution

- Adjust the headrest to the lowest position before folding. Turning the seat cushion over and then folding the backrest allows the backrest to be flattened for more storage space. Push the seat cushion forward slightly to flatten the backrest smoothly during the operation. Return the seat belt to its original position to avoid interference when folding the backrest. Remove all articles from the seat before folding the backrest.
- Do not place heavy objects on the backrest while it is in the folded position. Adjust the seat belt so that it does not get caught under the seat when the backrest is restored.
- Pull the backrest upward to restore it to the use position. Gently shake the backrest back and forth to ensure that the backrest is locked in place.

Before You Drive

Caution

- Before turning over the seat cushion, insert the locking buckle into the backrest groove (as shown in the figure) and remove all articles from the seat, adjust the front seat to the proper position to avoid interference when the seat cushion is turned over. Return the seat belt to its original position to avoid interference when the seat cushion is turned over.

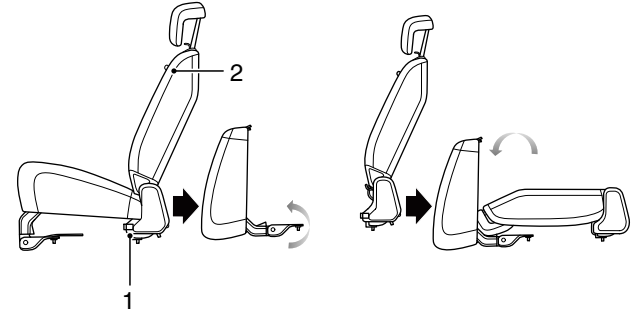
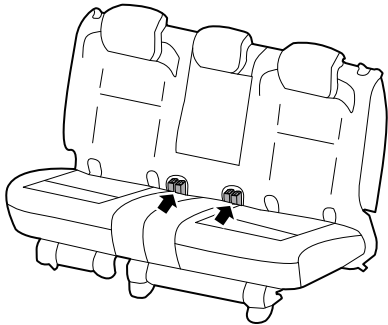

1

Pull the pull strap (1) to the side, the cushion will be unlocked, lift the side of the cushion to turn over the cushion forward until it is snug against the carpet. Pull up the pull strap (2) to unlock the backrest and turn over the backrest forward to a horizontal position.

To reset the seat, push the seat cushion forward slightly, then rotate the backrest to the backmost end and press the backrest backward to lock it to the body and rotate the cushion to secure it to the cushion lock. When resetting, be careful not to catch the seat belt latch webbing between the two rear seat backrests.

Before You Drive

Central armrest

Note: It applies to vehicles with the central armrest.

The rear seat armrests provide elbow support and arm comfort for rear occupants. The armrest can be used by pulling the strap at the top of the armrest outward and lowering it down.

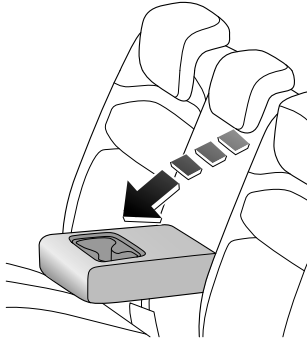

Caution

Do not sit on the central armrest or place heavy objects on it.

Seat heating

Note: It applies to vehicles with the seat heating function.

Press the left rear occupant seat heating switch (1), the indicator light on the switch will light up, and the left rear occupant seat heating function will be activated; Press the switch (1) again, the indicator light on the switch will turn off, and the heating function of the left rear occupant seat will be turned off.

Press the right rear occupant seat heating switch (2), the indicator light on the switch will light up, and the right rear occupant seat heating function will be activated; Press the switch (2) again, the indicator light on the switch will turn off, and the heating function of the right rear occupant seat will be turned off.

The seat heating function can be set through the seat interface in the vehicle settings on the central control screen. Press the second row left seat heating soft switch on the seat interface to activate the heating function of the left rear occupant seat; Press the soft switch again to turn off the heating function of the left rear occupant seat. Press the second row right seat heating soft switch on the seat interface to activate the heating function of the right rear occupant seat; Press the soft switch again to turn off the heating function of the right rear occupant seat.

Before You Drive

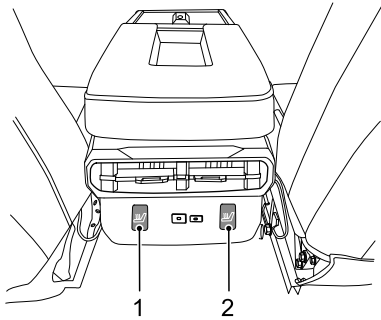

Note: *The seat heating function can only be activated after the vehicle is started, regardless of whether the air conditioning is turned on.*

Headrest

Note: *It applies to vehicles with adjustable headrest.*

! To reduce the risk of neck or head injury, the headrests should be adjusted to support the back of the head rather than the neck. Before driving the vehicle, adjust and ensure that the front and rear headrests are in the locked position (this is a safe position for use). Do not adjust the headrests while the vehicle is in motion. It is prohibited to drive with the headrests removed. Otherwise, in the event of a collision, the neck will be subjected to a tremendous impact, which could result in serious injury or even death. The lowest position of the headrests is not their use position, so be sure to adjust the headrests up to the locked position when using them. After adjusting the headrests, press down on the headrests to make sure they are locked securely.

Before You Drive

To raise the headrest, simply lift the headrest up to the desired position. To lower the headrest, press and hold the headrest adjustment button while lowering the headrest to the desired position. To remove the headrest, press and hold the headrest adjustment button while pulling the headrest out completely.

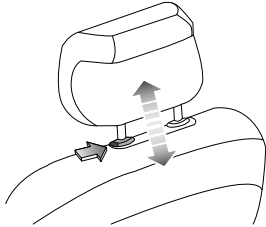

Occupant restraint system

Sitting correctly

The seat and its occupant restraint system have been designed to reduce personal injury to a minimum in the event of an accident. For optimum effectiveness, the following points should be observed.

- Do not position the seat nearer to the steering wheel than it is necessary.
- Do not over-recline the seat. Adjust the seat backrest to no more than 30° so that you can sit in an upright position with your arms slightly bent, and the base of your spine as far back as possible.
- Your headrest should be adjusted so that its center is level with the back of your head, not your neck.
- Diagonal belt should lie across the center of your shoulder (adjust its height if necessary) while lap strap fit tightly across the hips, not the abdomen.

Seat belts



Improperly wearing or using seat belts may cause serious personal injury or death. Seat belts are life saving equipment. In a collision, unrestrained occupants may collide anywhere inside the vehicle or be possibly thrown out, resulting in injury to themselves or to other occupants.

When riding in a vehicle, the driver and any adult (or any adult sized child) must always wear the seat belt. Do NOT slacken the webbing by pulling the belt away from your body. To be fully effective, the webbing must remain tightly around your body at all times. Avoid wearing thick, bulky clothing. Put the shoulder belt of seat belt across the center of the shoulder and the lap belt close to the body to go over the hips. Strictly prohibit the use of slack and twisted seat belts, and seat belts can not be twisted to wear.

Never use a seat belt for more than one adult, and never use it to secure an additional object or a child. Each seat belt can only be used by one occupant. It's dangerous to wrap a seat belt around a child in the occupant arms.

When wearing a seat belt, ensure that it is not twisted or slack. Otherwise the smooth operation of the belt may be impeded. The buckle release button must face outwards.



Do not allow a baby or infant to be carried on the lap. The force of a crash can increase effective body weight, making it impossible to hold onto the child.

Do not allow foreign matters (particularly sugary food and drinks) to enter the seat belt buckle- such substances may render the buckle inoperative.

If the seat belt has been used in a serious accident, or is seriously worn, or has been cut, or the visual load meter shows that the seat belt is no longer available, or the seat belt is a pretensioning seat belt with the pretensioner triggered, the seat belt assembly must be replaced.

Pregnant women should ask their doctor for advice about the safest way to wear seat belts.

A seat belt must not be altered or modified in any way, since such changes may render the belt ineffective. Do not attempt to dismantle, repair or lubricate the retractor or buckle mechanisms.

Each seat belt is fitted with a retractor. When the seat belt is pulled out slowly, the retractor can ensure that the seat belt is retracted freely. But if the seat belt is pulled out too fast or under a sudden impact (a sudden deceleration, acceleration, sharp turn), the seat belt will be locked. See "Seat belts" in Maintenance and Service section for the specific inspection methods.

Before You Drive

! When the seat belt is not used, be sure to retract the seat belt webbing completely, straighten the webbing and put the tongue in place, and keep the webbing and tongue clean to prevent dust and impurities.

Be careful to avoid the erosion of webbing by polishing agents, oils and chemicals (especially battery acid). It can be cleaned safely with mild soap and water. After wear, erosion or damage of the webbing occurs, the seat belt assembly should be replaced.

It can be dangerous to lie on the reclined seat while driving. As the seat belt cannot provide effective protection when you lie on the reclined seat. When accident occurs, your body will cross the shoulder belt and harm your neck or other parts. Lap belt will slide to your abdomen and apply force on it, which will cause serious injury.

Correct routing of the seat belts

! Make sure the seat belt is not pressed against the neck or abdomen. Never pass the seat belt behind the back or under the arms.

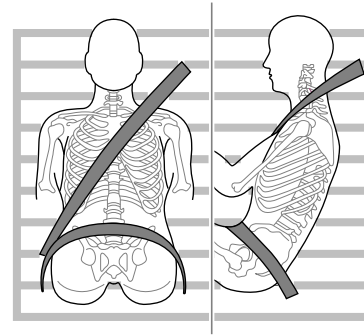

When wearing seat belts, the lap belt section should be positioned as low as possible across your hips. Never cross the abdomen. In the event of a collision, the lap belt can apply a force on the hips and reduce the possibility of you slipping under the lap belt. If you slip under the lap belt, the belt will apply force on your abdomen, which may cause serious or fatal injuries. The shoulder belt should cross the middle of the shoulder and the chest. In the event of emergency braking or collision, the shoulder belt will be locked. Never cross your neck, arms, or cross under your arms or behind your back.

To ensure that the seat belts always provide maximum protection, ensure the belt is flat, not loose and contacts the body. Adjust seat belt to ensure it is not loose.

Before You Drive

Seat belt use during pregnancy

If the seat belt is worn correctly, the mother and fetus will most likely not be harmed in a collision. Like all passengers, the pregnant woman may suffer from more serious injury in collision accidents or sudden stop if she does not wear the seat belt correctly.

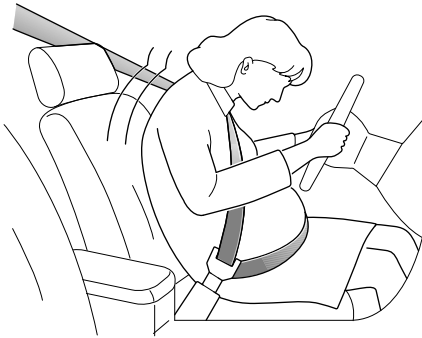

During the whole pregnancy, the pregnant woman shall wear the seat belt correctly. The shoulder belt should pass across the chest from proper position. The lap belt should pass below the belly, low and snug on the hip bones. The seat belt must be flat, causing no pressure on the lower body of the pregnant woman.

Please consult your physician for further details.

Seat belt use for people with disabilities

People with disabilities should also wear seat belts properly.

Please consult your physician for further details.

The driver seats and front occupant seats of the vehicles of this series can be configured with adjustable dual pretensioning force-limiting seat belts. The left and right seats of the rear occupant seats can be equipped with pretensioning force-limiting stop type seat belts, and the middle seat of the rear occupant seats can be equipped with non-pretensioning non-force-limiting seat belt.

 **Insert the tongue into the buckle until a distinct click is heard, which indicates the belt is locked.**

Before You Drive

Adjustable force-limiting seat belt with dual pretensioner

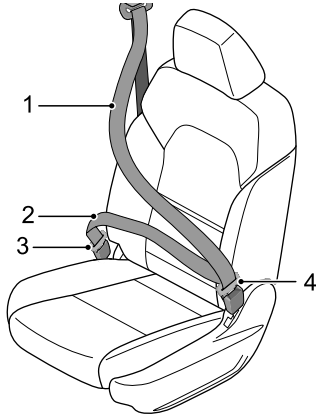

In the event of serious collision accident, the dual pretensioners (one integrated into the retractor, the other integrated into the side lap strap pretensioner) will be activated by the sensor, the shoulder belt (1) and the lap strap (2) will be contracted a little immediately at the same time to prevent the occupants from moving forward and make them seated securely, so that it improves the function of the seat belt further.

Fastening

The seat belt is pulled out of the scroll, passes through the shoulder to be fastened in front of the body, verify that the belt

is not twisted or tied, then push the movable tab (4) into the buckle that inside of the seat.

Loosening

Press the red button on the inner buckle, then the movable tab (4) will pop out under the action of the elastic force. Push the tongue back manually, so that the automatic seat belt retractor can contract the whole seat belt more easily.

The outer locking tab (3) does not need to be unlocked in the daily use.

Caution

The outer locking tab (3) should be unlocked by using the special tool, please ask Our Service Dealer to unlock it, if necessary.

Force-limiting stop type seat belt with pretensioner

In the event of serious collision accident, the pretensioner (integrated into the retractor) will be activated by the sensor, the shoulder belt will be contracted a little immediately to prevent the occupants from moving forward and make them seated securely, so that it improves the function of the seat belt further.

Fastening

The seat belt is pulled out slowly, passes through the shoulder to be fastened in front of the body, verify that the belt is not twisted or tied, then push the tongue into the buckle until a click is heard.

Before You Drive

Loosening

Press the red button on the buckle, then the tongue will pop out under the action of the elastic force. Push the tongue back manually, so that the automatic seat belt retractor can contract the whole seat belt more easily.

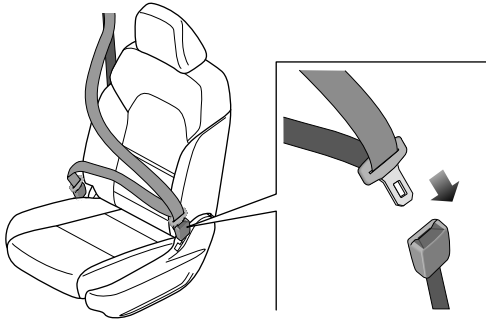

Three-point seal belt in the middle of rear seats

Fastening

Pull the seat belt out of the rear quarter, push the fixed tab (2) into the left buckle, then the movable tab (1) is passed through the abdomen and pushed into the right buckle.

1

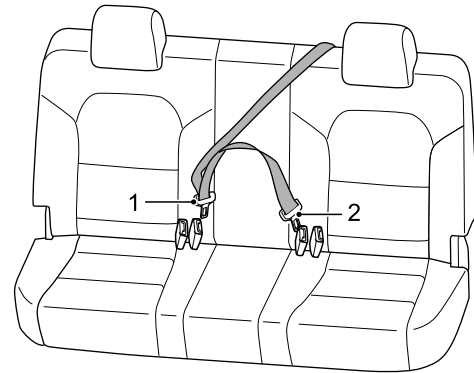

Loosening

The movable tab (1) is unlocked by pressing the red button on the right buckle.

The fixed tab (2) can be drawn out by inserting the key or other sharp objects into the left buckle unlocking hole. Push the

Before You Drive

tongue back manually, so that the automatic seat belt retractor can contract the whole seat belt more easily.

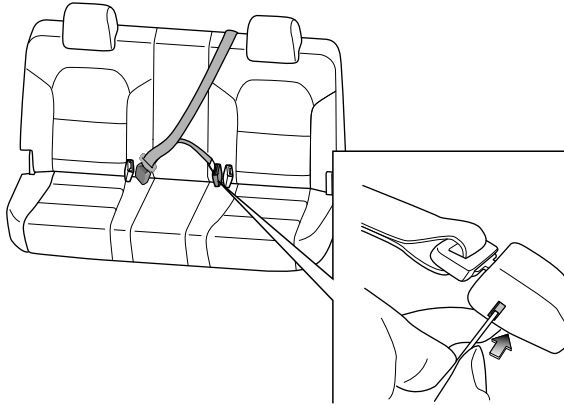

Seat belt warning light

See "Warning lights and indicators" in this section for the specific description of the "Seat belt warning light".

Seat belt height adjustment

! Ensure that the slide adjuster is secure after making an adjustment.

Do not adjust the height of the driver seat belt while driving, as the control of vehicle may be lost.

Only the height of the driver seat and front passenger seat shoulder-to-hip belt can be adjusted.

Pull the button (1) outward and slide the vertical adjuster on the top of the belt up and down to suit the passenger height. Release the button (1) at the proper position, pull the seat belt forcibly to ensure that the height adjuster is locked reliably.

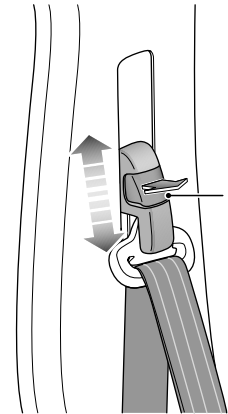

Seat belt pretensioner

 Do not damage or repair a pretensioner. It contains an ignition device, so that any maintenance can only be carried out by Our Service Dealer.

Pretensioners will not function after activation and must be replaced. In the event of a collision, ensure that the pretensioner and all seat belt components have been maintained by Our Service Dealer.

The seat belt pretensioner works together with the airbag to reduce the risk of injury in the event of a head-on collision.

Airbag(s)

 No safety system can provide complete protection for personal injury or death in a severe crash. Injuries or death can occur, even if seat belts are worn properly and the airbags are inflated.

After inflation some airbag components are hot - Do NOT touch until they have cooled.

An airbag is inflated with considerable force and can cause facial abrasions and other injuries. These effects can be minimized by ensuring that you and your occupant(s) are wearing seat belts.

The driver seat should be adjusted to be as far rearwards as possible while maintaining the proper control of the vehicle.

Always hold the steering wheel by its rim, so that the airbag can be inflated without obstruction.

Never attach accessory items e.g. a mobile phone bracket, cup holder, cassette tray, etc. to the steering wheel cover or the airbag module cover of the dashboard, or stick/insert anything to an airbag module cover. Otherwise, these objects could interfere with inflation of the airbag, or after the airbag is inflated, they will be propelled into the vehicle to cause injury to occupants.

Before You Drive



Do not allow an occupant to obstruct the deployment of the airbag by putting feet, knees, etc. in contact with, or in close proximity to the airbag module cover of the dashboard.

It is forbidden to put the seat cover and other related decorative seat items that affect the deployment of seat airbags on the seats equipped with seat airbags.

Do not modify the seats equipped with seat airbags at will.

Do not paste any sharp objects on A, B and C pillars of the vehicle at will, and modify A, B and C pillars, so as to avoid injuries to occupants during the operation of airbags.

The seat belt pretensioner works together with the airbag to reduce the risk of injury in the event of a head-on collision.

Do not attempt to remove or pierce the steering wheel, or hit it violently.

Do not allow another person, animal or object to occupy the space between the driver and the deploying range of the airbag. The same applies on the occupant side if an airbag is fitted.



Do not attempt to maintain the steering wheel, steering column, any airbag system or pretensioner component, or the airbag components with wiring around. Otherwise, it could cause inadvertent activation of the system resulting in personal injury.

Do not modify the front of the vehicle in any way as this could adversely affect airbag deployment.

If the vehicle is to be scrapped, undeployed airbags are potentially dangerous and should be deployed before scrapping. This operation must be done by professional staff.

This vehicle can be equipped with the driver airbag, front occupant airbag, driver side airbag, front occupant side airbag, driver seat far-end side airbag and side air curtain.

Note: *Both the airbag and the pretensioner are supplementary protection device, while the seat belt is still the main protection device and must be worn during driving.*

Before You Drive

Caution

- When an airbag is triggered, a loud noise may be heard and a small amount of smoke-like gas and dust will be released. This smoke does not constitute a health hazard. The dust may be an irritant to the skin and therefore should be washed off with soap and water.
- For safety reasons you are recommended to have the airbag(s) renewed by Our Service Dealer every 10 years. If the vehicle is sold, its owner is obliged to notify the purchaser of the cautions and warnings listed. This obligation is met by handing over these instructions (See Warranty & Service Handbook) to the new owner.

Airbag and pretensioner check



After the vehicle is powered on, if the warning light is not turned on or not turned off after about a few seconds, or turned on when driving, it indicates that the seat belt pretensioner or the airbag is faulty. Contact Our Service Dealer for service as soon as possible.

Each time the vehicle is powered on, the "airbag warning light



(red)" will illuminate for about a few seconds, which indicates that the airbag and seat belt pretensioner inspection is in progress; it goes off after about a few seconds, which indicates that the airbag and seat belt pretensioner are normal.

Before You Drive

Airbag deployment



Incorrect sitting posture or sitting or resting on the place close to the airbag will result in serious and even fatal injuries when the airbag is deployed.

In order to reduce the injuries caused during the airbag deployment, the seat belt must be always worn properly. The driver and front occupant must have a good sitting posture, and adjust their seat positions to enable them to be far enough away from the front airbag, so as to avoid causing serious injury or death when the airbag is deployed. For vehicles equipped with side airbags and side air curtains, it is also important to ensure that upper extremities are far enough away from the side of the vehicle, avoiding injuries due to airbag deployment.

When the airbag is deployed, children not properly protected may suffer serious injury and even death. Do not hold a child in your arms or put the child on your lap when riding on a vehicle. Do not allow children to ride on a vehicle without protection, and it is prohibited to stick any part of the body out of the window.

The airbag deployment may cause body surface abrasion or bruise or burns due to explosion.



There must be no obstacle in the airbag inflation channel. It is prohibited to place any object between the occupant and the airbag. It is prohibited to fix or place any object on the steering wheel cover or the frontal airbag cover of instrument cluster and its vicinity. It is prohibited to place accessories around the airbag system. If there is obstacle between the occupant and the airbag, the airbag may not be properly inflated, or squeeze the obstacle into the body of occupant, causing serious injury or death.

Do not knock on or crash the airbag or positions of relevant components, to avoid causing serious injury or death due to airbag deployment.

When it is deployed, some airbag components are hot, so do not contact it before cooling down.

In case of crash, airbag control module detects speed change caused by crash to determine airbag deployment. The airbag will deploy instantaneously and powerfully with a loud noise.

When the vehicle is subject to serious front crash, fully deployed airbag along with properly worn seat belt can limit the movement of the driver and the front occupant, thereby reducing the risk of injury to the head and chest. For vehicles equipped with side airbags and side air curtains, if the side of vehicle is seriously crashed, fully deployed side airbag will form an air cushion between the occupant and the side of vehicle, thereby reducing the risk of injury to the side of occupant body.

Before You Drive

When you are sitting upright in the seat and leaning against the seat backrest, the seat belt and the airbag can provide the most effective protection. In case of a serious crash, the airbag deploys violently. At this moment, if you or other occupant does not properly use the seat belt, and tilts the body forward, reclines or has other incorrect posture, the possibility of serious injury or death in an accident will be high.

Caution

- The airbag cannot protect the lower part of occupant body.
- The airbag is not designed for rear collision or slight frontal impact or vehicle overturn, and it does not work during the emergency braking.
- Airbag deployment and contraction are completed in a very short time, and will not provide protection from effects of possible subsequent second impact.
- Upon deployment, the airbag will shrink immediately to ensure the driver could look forward without block.

- Schematic diagram for deployment area of driver and front occupant airbags

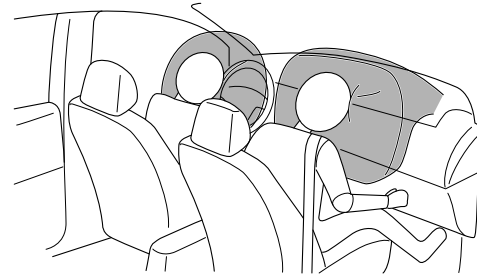

- Schematic diagram for deployment area of side airbags, driver seat far-end side airbag and air curtains

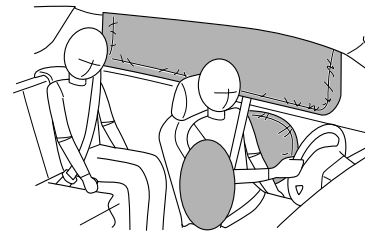

Before You Drive

Frontal airbag

! Do not install the children restraints on the front occupant seat. Frontal airbag deployment will cause serious injury or death to children.

The driver and the front occupant shall not let their feet, knees or other parts of body contact with or get close to the frontal airbag cover.

The airbag may deploy in the event of violent jolt or accidental impact to the vehicle chassis. Therefore, be extra careful when driving on a bumpy road, to avoid injuries caused by accidental airbag deployment.

The frontal airbag is designed to deploy in the event of front impact or similar collision. The airbag will deploy under any of the following situations or similar situations.

- Front impact at a relatively high speed with solid wall which cannot move or deform.

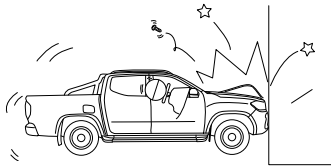

- When the vehicle chassis is seriously damaged. When the vehicle collides with the curbstone, road pavement edge or solid surface, and falls into the deep ditch or deep hole, or violent contact with the ground after vehicle jump may cause serious damage to the chassis.

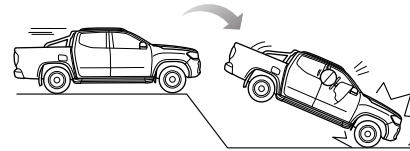
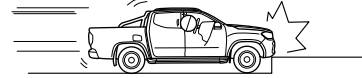

Before You Drive

Side airbag and driver seat far-end side airbag

⚠ The structure and material of seat is critical for the operation of airbag. Therefore, do not install the seat cover, which will affect the deployment of side airbag.

In case of serious side impact, the front seat side airbag on the side subject to impact will pop out from the seat cover and deploy rapidly. The side airbag on the side not subject to impact will not deploy. The side airbag will deploy under any of the following situations or similar situations.

- Side impact occurs between the vehicle and the general occupant car at a relatively high speed.

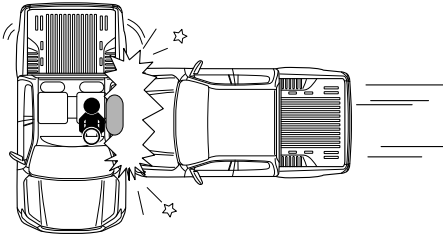

Side air curtain

In case of serious side impact, the side air curtain on the side subject to impact will pop out from the headliner and deploy rapidly. The side air curtain on the side not subject to impact will not deploy. The side air curtain will deploy under any of the following situations or similar situations.

- Side impact occurs between the vehicle and the general occupant car at a relatively high speed.

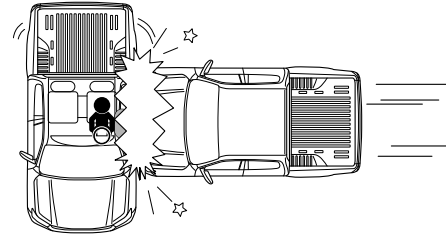

Before You Drive

Conditions for airbag undeployment

Airbag will deploy based on the crash object, direction and vehicle deceleration caused by crash rather than vehicle speed. When the impact force of crash is absorbed or dispersed on the vehicle body, the airbag may not deploy; but based on the impact condition during the accident, the airbag may sometimes explode. Therefore, damage severity of vehicle shall not be considered as the judgment of airbag deployment.

Frontal airbag

The side airbag may not deploy under any of the following situations or similar situations.

- When the impact direction deviates from the center of vehicle.
- When front impact occurs with solid electric pole, traffic sign post, trees and other small objects.

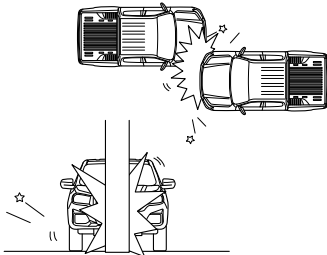

- Impact with lower part of truck tailgate; piercing-type impact with truck or vehicles with higher chassis.
- Front offset impact with guardrail.

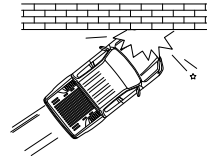
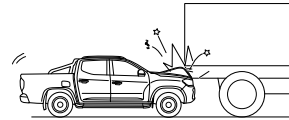

- Side or rear impact.
- Vehicle rollover.

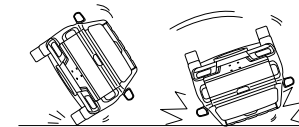

Before You Drive

Side airbag, driver seat far-end side airbag and side air curtain

The side airbag and side air curtain may not deploy under any of the following situations or similar situations.

- Impact at a certain angle with the side.
- Side impact with a two-wheel motorcycle.

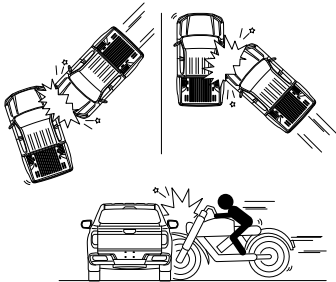

- Side impact with the front compartment of vehicle.
- Side impact with the rear of vehicle.
- Vehicle rollover.

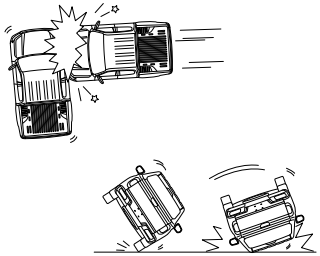

- Front offset impact with guardrail.
- Side impact with a post.

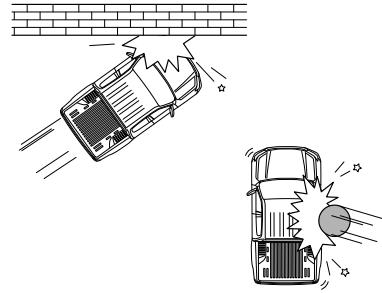

- Front impact with a stationary or moving vehicle.
- Rear impact.

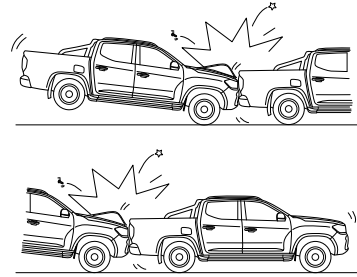

Before You Drive

Replace airbag system components after a collision accident



The airbag system could be damaged due to a collision accident. Thus the airbag system cannot operate normally to protect you and occupants in future collision accidents resulting in serious injury even death. To ensure the airbag system remains valid after a collision accident, consult Our Service Dealer to make inspection and necessary replacement of components.

Once the airbag is inflated, it is required to replace the components of the airbag system. Contact Our Service Dealer for service as soon as possible.

Event data recorder (EDR)

This vehicle is equipped with an event data recorder (EDR). The main function of EDR is to record the data of vehicle movement and safety system status within a short time during collision or near collision, which can be used to reproduce the state of the vehicle before, during and after collision, such as vehicle speed, accelerator pedal opening, and brake pedal depth. The EDR data extraction tool reads data based on the 11-bit CAN identifier, and reads the EDR data by using the 2216 "Reading data service by data identifier" service in 11.2 of ISO 14229-1:2020 by means of physical addressing. The data can be read from the airbag controller with our dedicated after-sales scan tool. You can log in to the corresponding link of our official website to purchase the EDR data reader.

Before You Drive

Child restraints (not available with the vehicle)

General points relating to child seat

Although one of our company's main criteria when designing your vehicle, the safety of your children also depends on you.

May result in death or serious injury!

Observe the instructions provided by the infant or child restraint device's manufacturer if you are installing or using such device.

WARNING: child restraint anchorages are designed to withstand only those loads imposed by correctly fitted child restraints. Under no circumstances are they to be used for adult seatbelts, harnesses, or for attaching other items or equipment to the vehicle.

For maximum safety, please observe the following recommendations:

- In accordance with regulations, all children under the age of 12 or less than one and a half metres tall must travel in approved child seats suited to their weight, on seats fitted with a seat belt or ISOFIX/i-Size mountings.
- Statistically, the safest seats in your vehicle for carrying children are the rear seats.
- A child weighing less than 9 kg (or under 15 months old) must travel in the rearward facing position both in the front and in the rear.

 We recommends that children should travel on the rear seats of your vehicle:

- Rearward facing up to the age of 3.
- Forward facing over the age of 3.

Note: The regulations on carrying children are specific to each country. Refer to the legislation in force in your country.

Below are instructions must be followed when using a child seat on the front passenger seat

Rearward facing

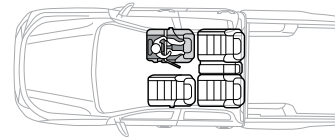

The front passenger airbag must be deactivated when using a rear-facing child seat on the front passenger seat. Once the rear-facing child seat is removed from the front passenger seat, the front passenger airbag must be activated immediately.

Before You Drive

If needed, adjust the front seats to the appropriate position(fore/aft) for proper installation of child seat or to avoid the interaction between the child seat and IP facia.

If needed, adjust the front seats to the appropriate height for proper installation of child seat.

If needed, the front passenger seatback can be adjusted so that there is full support between the child seat and vehicle seat.

⚠ Adjust or remove the head restraint when installing the child seat on the front passenger seat so that the front passenger seat or head restraint provides full support to the child seat.

Ensure that the vehicle seat belt passes through the child seat or occupant without getting tangled or bending.

Note: Refer to the legislation in force in your country before installing a child seat on this seating.

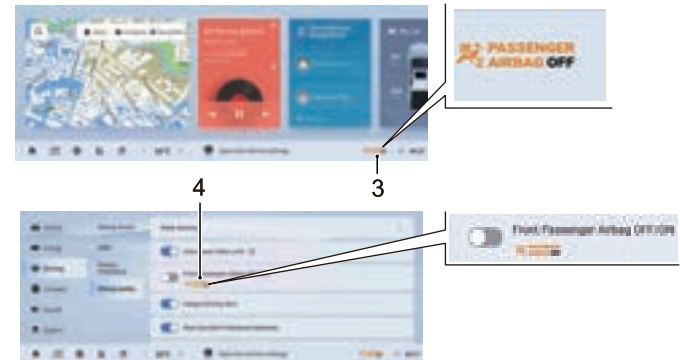
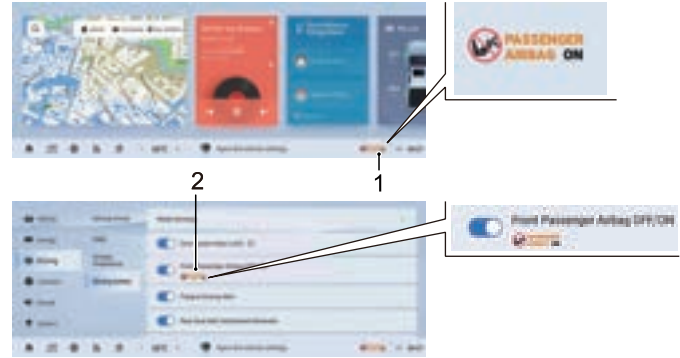

- 1 Front passenger airbag status indicator and the status is on
- 2 Front passenger airbag switch and the status is on
- 3 Front passenger airbag status indicator and the status is off

Before You Drive

4 Front passenger airbag switch and the status is off

Note: As the entertainment system software will continue to be updated and iterated, the pictures in this manual are only schematic diagrams, which may be slightly different from this vehicle. They are for reference only, and the actual vehicle status shall prevail.

The front passenger airbag is on by default and can be turned off/on in the following two ways.

- 1 Front passenger airbag status indicator is on the status bar below of the central control screen. Tap the front passenger airbag status indicator to enter the Safety & Convenience interface, then slide down and tap the front passenger airbag switch.
- 2 Tap  to enter the Safety & Convenience interface, then slide down and tap the front passenger airbag switch.

Note: When you turn off the front passenger airbag, the central control screen will display the following prompt. Click "Confirm" to turn off the front passenger airbag.

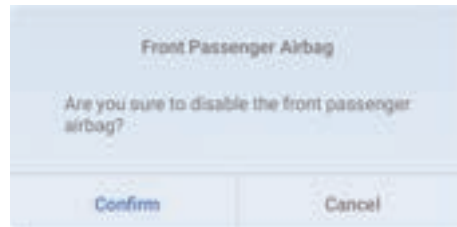

Forward facing

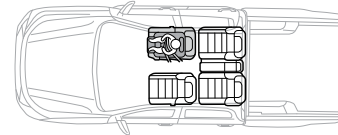

If needed, adjust the front seats to the appropriate position (fore/aft) for proper installation of child seat or to avoid the interaction between the child seat and IP fascia.

If needed, adjust the front seats to the appropriate height for proper installation of child seat.

If needed, the front passenger seatback can be adjusted so that there is full support between the child seat and vehicle seat.

! Adjust or remove the head restraint when installing the child seat on the front passenger seat so that the front passenger seat or head restraint provides full support to the child seat.

Ensure that the vehicle seat belt passes through the child seat or occupant without getting tangled or bending.

Before You Drive

Note: Refer to the legislation in force in your country before installing a child seat on this seating.

Deactivating the passenger's front airbag

! Never install a rearward facing child restraint system on a seat protected by an active front airbag. This could cause the death of the child or serious injury.

The warning label present on both sides of the passenger's sun visor repeats this advice.

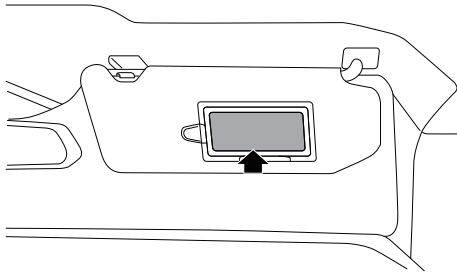

Below are instructions that must be followed when using a child seat on the rear seats

Rearward facing

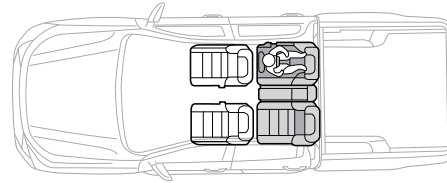

Forward facing

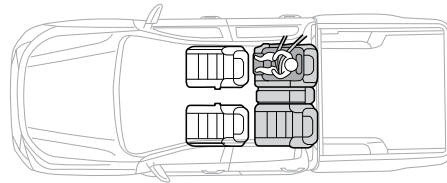

If needed, adjust the second row seat to appropriate position or seatback angle for proper installation of child seat.

Before You Drive

If needed, adjust any front passenger seat (fore/aft) in case there is an interaction between the child seat/child and the respective front seat.

Adjust or remove the head restraint when installing the child seat so that the passenger seat or head restraint provides full support to the child seat.

Ensure that the vehicle belt passes through the fitting guide attached to the child seat without getting tangled or bending.

ISOFIX/i-Size mountings

Your vehicle has been approved in accordance with the latest ISOFIX/i-Size regulation.

- The seats, represented below, are fitted with regulation ISOFIX/i-Size mountings:

Note: If the center seat of second row can available, the same as the outside adjustment.

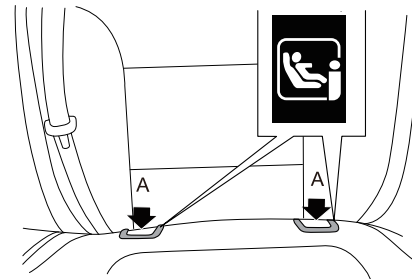
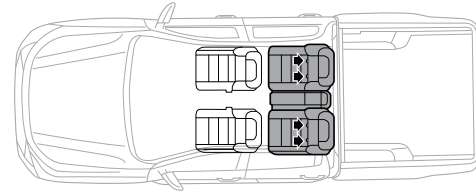

Before You Drive

- Two rings A, located between the vehicle seat back and cushion, indicated by a marking.

! For information on the possibilities for installing ISOFIX/i-Size child seats in your vehicle, refer to the summary table.

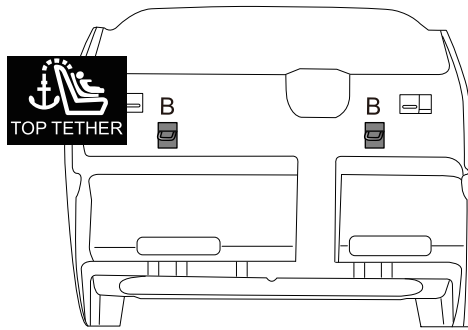

- One ring B behind the seat and identified by a marking, referred to as the Top Tether for fixing the upper strap.
- This ISOFIX/i-Size mounting system provides fast, reliable and safe fitting of the child seat in your vehicle.
- The ISOFIX/i-Size child seats are fitted with two latches which are secured on the two rings A. Some seats also have an upper strap, known as the Top Tether, which is attached to ring B.

! Allows for an extension strap to be used, if the length of the CRS strap (in some cases for rearward facing CRS) is not long enough to reach the anchorage.

- To secure the child seat to the TOP TETHER:
 - Unlock the second row seat back to expose the Top Tether.
 - If needed, adjust the head restraint or remove and stow the head restraint before installing the child seat on the seat for better tightening the upper strap (refit the head restraint once the child seat has been removed).
 - Fix the hook of upper strap to the ring B.
 - Tighten the upper strap.
 - Lock the second row seatback.

! The incorrect installation of a child seat in a vehicle compromises the child's protection in the event of an accident. Follow strictly the fitting the instructions provided with the child seat.

Before You Drive

Recommended types of child seats

ECE-R129 classification is based on a child height

Child stature	Manufacturer	Type	Accessory
40-83cm	Dorel Europe	Maxi Cosi Pebble 360	Belt
61-105cm	HTS BeSafe	BeSafe iZi Kid X3 i-Size	ISOFIX + Support leg
100-150cm	Britax Römer	*Britax Kidfix i-Size	Belt + ISOFIX
135-150cm	OSANN	Universal booster cushion	Belt

*: For the best protection, it is recommended to use this child restraint system with the included backrest and be sure to attach the seat belt through Secure Guard , SICT and XP-pad.

1

Before You Drive

Locations for child seats secured using the seat belt

In accordance with European regulations, this table indicates the options for installing child seats secured using the seat belt and universally approved in relation to the weight of the child and the seat in the vehicle.

Seat position number	Seat position						Remark
	Front-Driver	Front-Passenger With front passenger airbag activated	Front-Passenger With front passenger airbag deactivated	Rear left	Rear centre	Rear right	
Seating position suitable for universal belted (Yes/No)	No	Yes Forward facing only	Yes	Yes	Yes	Yes	
i-size seating position (Yes/No)	No	No	No	Yes	No	Yes	
Seating position suitable for lateral fixture (L1/L2)	No	No	No	No	No	No	
Largest suitable rearward facing fixture (R1/R2X /R2/R3)	No	No	No	(R1/R2X /R2/R3)	No	(R1/R2X /R2/R3)	
Largest suitable forward facing fixture (F2X/F2/F3)	No	No	No	(F2X/F2/F3)	No	(F2X/F2/F3)	

Before You Drive

Seat position number	Seat position						Remark
	Front-Driver	Front-Passenger With front passenger airbag activated	Front-Passenger With front passenger airbag deactivated	Rear left	Rear centre	Rear right	
Largest suitable booster fixture (B2/B3)	No	(B2/B3)*	(B2/B3)*	(B2/B3)	(B2/B3)*	(B2/B3)	
<p>* Only applicable for installation with seat belt</p> <p>During the Installation of the CRS, the backrest angle and height of the front passenger seat should be adjusted reasonably to ensure that the CRS remains stable.</p> <p>During the installation of the CRS, the height of the headrest should be adjusted reasonably or the headrest should be removed to avoid interference with the CRS. Do not to remove the head restraint when using a booster cushion with no backrest.</p>							



Remove and stow the head restraint before installing a child seat with a backrest on a passenger seat. Refit the head restraint once the child seat has been removed.

When installing a CRS on the front passenger seat, the below instructions can be followed if needed:

- **Adjust the front seats to the appropriate position(fore/aft) for proper installation of child seat or to avoid the interaction between the child seat and IP facia.**
- **Adjust the front seats to the appropriate height for proper installation of child seat.**
- **Adjust the front passenger seatback to have full support between the child seat and vehicle seat.**

When installing a CRS on the second row or third row seat, the below instructions can be followed if needed:

- **Adjust the second row seat to appropriate position for proper installation of child seat.**
- **Adjust any front passenger seat (fore/aft) in case there is an interaction between the child seat/child and the respective front seat.**

Before You Drive

Instruments and controls

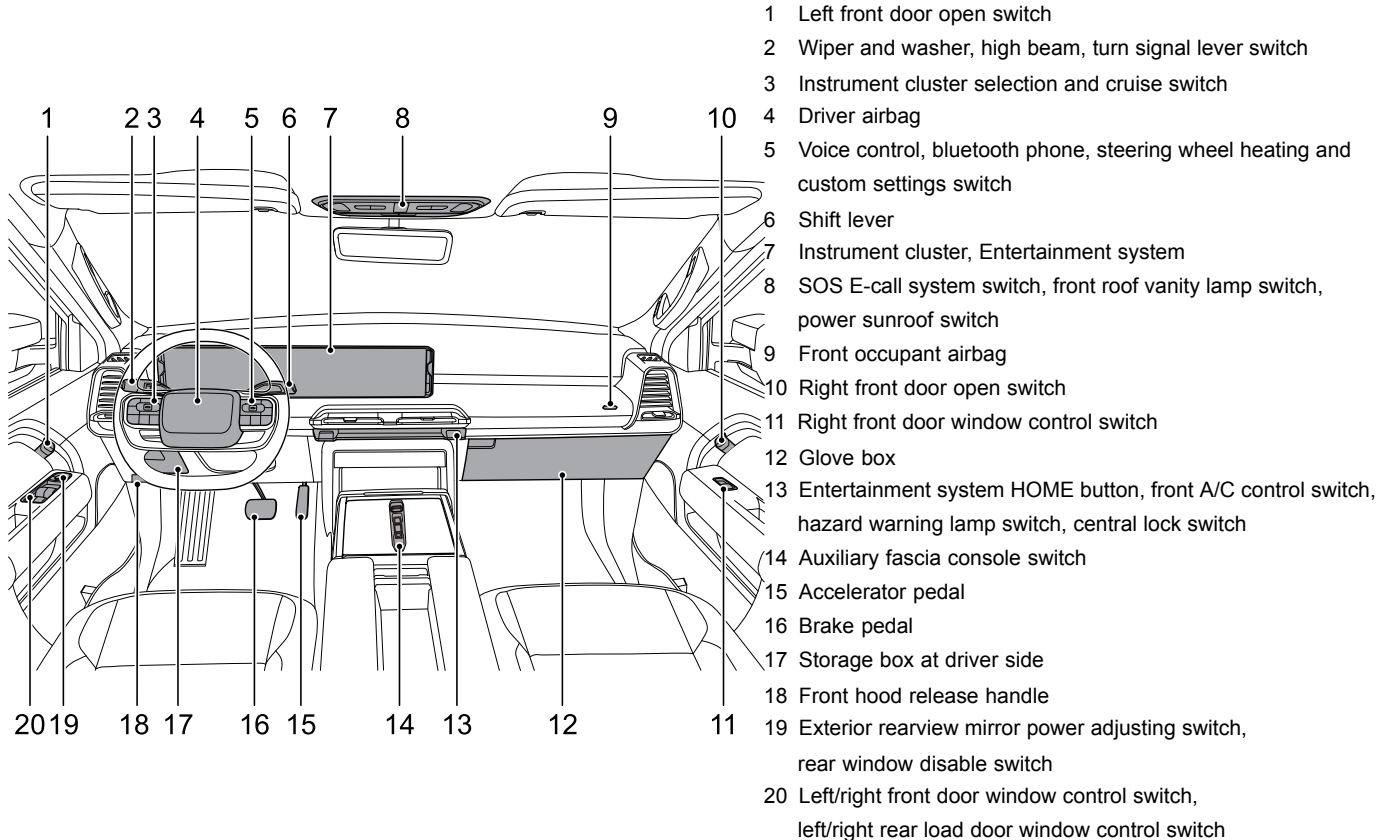

Before You Drive

Instrument cluster



- 1 High-voltage battery pack quantity meter
- 2 Power meter
- 3 Speedometer

Caution

Don't place any object in front of the instrument cluster to avoid shielding dial and warning light.

High-voltage battery pack quantity meter

The quantity meter indicates the status of high-voltage battery pack quantity through the illuminated battery icon ratio. When the battery is too low, the red bar illuminates, and "high-voltage battery pack low battery warning lamp (yellow)" also illuminates.

Note: Low battery of high-voltage battery pack will result in failure of some functions on the vehicle.

Caution

Charge the high-voltage battery pack as soon as possible when the battery is low.

Please ensure the high-voltage battery pack stores enough power before driving.

After the vehicle is filled with electricity, the battery management system will have automatic calibration function. After the vehicle has been shallowly charged (less than 99%) every two to three times, the vehicle will be completely charged for once (filled with electricity).

Speedometer

The speedometer indicates the current road speed in kilometers per hour.

Power meter

The power meter displays the power percentage of power system. Power display range is -25 ~ 100%, when the maximum or minimum value is exceeded, the maximum or minimum value shall be indicated.

Caution

The power meter indicates the power percentage, not the calculated actual power.

Before You Drive

Message center

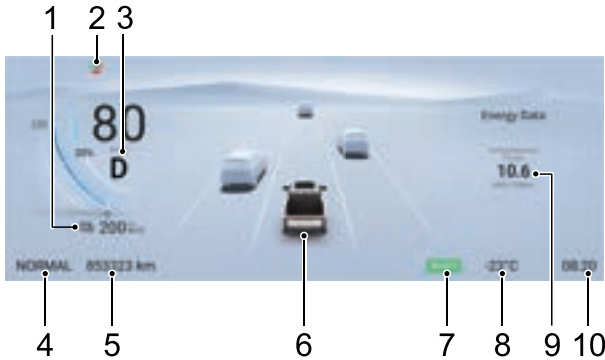

1 Driving mileage

It displays the range that can be driven before electric quantity of the high-voltage battery is used out.

2 Energy recovery level

It displays the energy recovery level of current vehicle, which is divided into three levels of high, standard and low and displayed by numbers of 3, 2 and 1 on the instrument cluster respectively. The high energy recovery is larger than the standard energy recovery, and the standard energy recovery is larger than the low energy recovery. The energy recovery level can be switched through the energy recovery switch on the central control screen.

3 Gear information

4 Driving mode

It displays the driving mode of current vehicle. The driving modes of the two-wheel drive model include NORMAL, ECO, and SPORT, which can be switched through the driving mode switch on the central control screen. Please see "All-terrain system" in Starting and Driving section for the driving mode indicators of four-wheel drive models.

5 Total distance (ODO)

6 ADAS (Advanced Driver Assistance System) function display (when the vehicle is not configured with ADAS, only its own vehicle model is displayed)

It displays the information related to the driver assistance system configured on the current vehicle.

7 Power system state

When the vehicle is powered on, if the "READY indicator lamp (green)" of vehicle illuminates to indicate that the power system is ready, the vehicle can be driven.

8 Outdoor temperature

9 Trip data card interface

10 Current time

Note: If the vehicle is not configured with the relevant function, the interface will not be displayed.

Right function display information

Calendar time

It displays the date information.



Multi-media interface

It is projected to the right side of instrument for display through the button on the central control screen. Multi-media interface displays current music/radio program information.

Trip data card interface

Trip data interface includes energy data, current trip and total trip subpage.

Short press the button  on the instrument cluster selection

switch  on the steering wheel to call out the trip data card interface, and press  to hide the trip data card interface; on the trip data card interface, short press upward and downward

the instrument cluster selection switch  on the steering wheel to switch the following interface contents:

- Energy data
It displays the instantaneous power consumption information.
- Current trip
It displays the trip, average power consumption, driving time and average speed since the vehicle is powered on and started.

- Total trip
It displays the trip, average power consumption, driving time and average speed since the last reset.
On this interface, long press the instrument cluster selection switch  to reset the trip, average power consumption, driving time and average speed.

Before You Drive

Alarm messages

Most of alarm messages will have a corresponding graphic and text description in the instrument cluster. When the message is displayed, the alarm indicator lamp also illuminates.

If more than one alarm message is activated, the alarm messages will be displayed in a cycle based on priority; each alarm message will be displayed for 3 seconds.

The priority of alarm message is higher than that of trip data card message, after the vehicle is powered on, the alarm message will be displayed first.

Please operate in strict accordance with the instructions in the alarm message. If there are relevant instructions, please stop the vehicle for inspection or consult Our Service Dealer.

Important alarm messages

The currently displayed important alarm message can be temporarily shielded by short pressing the instrument cluster



selection switch or automatically shielded 9 seconds later. It can also be viewed in the alarm query interface if the alarm is not canceled.

If all the alarm messages are shielded, the trip data card message will be displayed normally.

When the conditions of alarm activation are canceled, the corresponding alarm messages are also canceled to display.

Indicative messages

Indicative messages disappear automatically after 3 seconds.

Caution

Don't neglect the alarm messages, otherwise it may cause serious damage to the vehicle. If the alarm indicator lamp is on, please stop the vehicle as soon as possible if it is safe to do so.

Maintenance interface reminder

When the vehicle maintenance node is approaching, it will prompt the user to perform maintenance in time.

Tire pressure monitoring system

Note: *It is applicable to models with tire pressure monitoring system.*

The tire pressure monitoring system automatically monitors the tire conditions in real time, providing effective safety guarantee for driving.

When the tire pressure is insufficient, too high, or the tire leaks quickly or the system fails in the course of driving, the "TMPS

warning lamp (yellow)"  on the instrument cluster will illuminate, accompanied by a sound prompt, and the instrument display shows the corresponding alarm interface.

Warning lights and indicators

Direction indicator



The left or right "direction indicators (green)" flash when making a turn. When the hazard warning light switch is pressed, the left and right direction indicators flash simultaneously.

Note: *If a direction indicator flashes rapidly, it indicates that the bulb in this direction indicator is faulty.*

Headlamp low beam indicator



The "headlamp high beam indicator (green)" illuminates when the headlamps are on low beam.

Headlamp high beam indicator



The "headlamp high beam indicator (blue)" illuminates when the headlamps are on high beam or flash on.

IHC (Intelligent High beam Control) indicator

Note: *It applies to vehicles configured with the IHC.*



With the vehicle powered on, when IHC system controls the high beam to illuminate, "IHC indicator (blue)"

Before You Drive

illuminates; when IHC system controls the high beam to go out, "IHC indicator (grey)" illuminates. See "IHC (Intelligent High beam Control)" in the Starting and Driving section for more information.

Rear fog lamp indicator



The "rear fog lamp indicator (yellow)" illuminates when the rear fog lamps are on.

Position lamp indicator



The "position lamp indicator (green)" illuminates when the position lamps are on.

IMMO warning light



With the vehicle powered on, if the immobilizer authentication is successful, the "IMMO warning light (yellow)" will go out and the vehicle can be started.

If the "IMMO warning light (yellow)" flashes, it indicates that the immobilizer control system is faulty, and the vehicle cannot be started. Please contact Our Service Dealer for service immediately.

TPMS warning light



With the vehicle powered on, when the TPMS breaks down, the "TPMS warning light (yellow)" will illuminate. Please contact Our Service Dealer for service.

Battery charging indicator



With the vehicle powered on, the "battery charging indicator (red)" illuminates, and goes out after the vehicle is started.

Caution

If the warning light stays on after the vehicle is started or illuminates during driving, it indicates that the charging system has a malfunction, please contact Our Service Dealer for service as soon as possible.

READY indicator



This light is used to indicate that the vehicle is ready for running. After the vehicle is started, the "READY indicator (green)" will illuminate and will not go out in the running process.

Charging connection indicator



After charging connector is connected to charging interface, the "charging connection indicator (red)" will illuminate.

Charging status indicator



When the high-voltage battery pack is being charged, the "charging status indicator (yellow)" will illuminate. When the high-voltage battery pack has been charged, this indicator will go out.

Note: If the "charging status indicator (yellow)" flashes, it means that battery is faulty and it cannot be charged. Contact Our Service Dealer for service as soon as possible.

Power system fault warning light



With the vehicle powered on, if the power system breaks down, the "power system fault warning light (yellow/red)" will illuminate. Please contact Our Service Dealer for service.

Warning light of high-voltage battery pack for low electric quantity



With the vehicle powered on, if the "warning light of high-voltage battery pack for low electric quantity (yellow)"

illuminates, it means that electric quantity of high voltage battery pack is too low and it need be charged as soon as possible. You shall supplement electric quantity before lighting this light.

Note: If the warning light illuminates, it means that speed limit function of the vehicle has been started. Vehicle speed will be reduced with decrease of electric quantity of the battery until it is stopped.

Insulation fault warning light



With the vehicle powered on, if the "insulation fault warning light (red)" illuminates, it means that the vehicle has insulation fault.

Power-limit Indicator



In normal driving state, the "power-limit indicator (yellow)" keeps off. When the "Limited Power Indicator (yellow)" illuminates, the power of the vehicle will be limited and the acceleration performance will be significantly weakened. Contact Our Service Dealer for a check as soon as possible.

Airbag warning light



With the vehicle powered on, if the "airbag warning light (red)" illuminates or flashes, it means that the airbag system

Before You Drive

is faulty. Contact Our Service Dealer for service as soon as possible.

Front passenger airbag warning light

Note: *It applies to vehicles configured with the front passenger airbag warning light.*



With the vehicle powered on, if the "front passenger airbag warning light" illuminates or flashes, it means that the front passenger airbag system is faulty. Contact Our Service Dealer for service as soon as possible.

Front passenger airbag ON warning light

Note: *It applies to vehicles configured with the front passenger airbag ON warning light.*



With the vehicle powered on, if the "front passenger airbag ON warning light" illuminates, it indicates that the front passenger airbag is in the open state. At this time, a child safety seat facing forward cannot be installed on the front passenger seat.

Front passenger airbag OFF warning light

Note: *It applies to vehicles configured with the front passenger airbag OFF warning light.*



With the vehicle powered on, if the "front passenger airbag OFF warning light" illuminates, it indicates that the front passenger airbag is in the off state.

Seat belt warning light

Note: *This vehicle can be equipped with the rear row seat belt unfastened warning functions, which shall be subject to the actual configuration of the vehicle you purchased.*



With the vehicle powered on, if the driver seat belt is not correctly fastened, the "seat belt warning light (red)" will illuminate. When the speed is higher than 22 km/h, if the driver seat belt is not correctly fastened, the instrument cluster will activate a seat-belt-unfastened audible warning, and the "seat belt warning light (red)" will flash for about 90 seconds. When the seat belt is fastened, the "seat belt warning light (red)" goes out and the audible warning stops. When the vehicle is in reverse gear or the speed is lower than 10 km/h, if the driver seat belt is not correctly fastened, the instrument cluster will not activate any audible warning, while the "seat belt warning light (red)" will illuminate. When the seat belt is fastened, the "seat belt warning light (red)" goes out.

With the vehicle powered on, if the front occupant seat belt is not correctly fastened, the "seat belt warning light (red)" will illuminate. When the speed is higher than 22 km/h, if the front occupant seat belt is not correctly fastened, the instrument

cluster will activate a seat-belt-unfastened audible warning, and the "seat belt warning light (red)" will flash for about 90 seconds. When the seat belt is fastened, the "seat belt warning light (red)" goes out and the audible warning stops. When the vehicle is in reverse gear or the speed is lower than 10 km/h, if the front occupant seat belt is not correctly fastened, the instrument cluster will not activate any audible warning, while the "seat belt warning light (red)" will illuminate. When the seat belt is fastened, the "seat belt warning light (red)" goes out.

When the occupant seat belt (equipped with rear row occupant seat belt unfastened warning function) is not fastened properly, the "seat belt warning light (red)" illuminates. When the speed is higher than 22 km/h and the occupant seat belt (equipped with the rear row occupant seat belt unfastened warning function) is not properly fastened, the instrument cluster activates a seat-belt-unfastened audible warning, and the "seat belt warning light (red)" flashes for about 90 seconds and there is seat map showing the specific unfastened seat. When the occupant seat belt (equipped with the rear row occupant seat belt unfastened warning function) is fastened properly, the "seat belt warning light (red)" goes out and the audible warning stops. When the speed is lower than 10 km/h and the occupant seat belt (equipped with the rear row occupant seat belt unfastened warning function) is not properly fastened, the "seat belt warning light (red)" illuminates. When the occupant seat belt (equipped with the rear row occupant seat belt unfastened warning function) is fastened properly, the "seat belt warning light (red)" goes out.

Note: *Opening the door will reset the time when the seat belt warning light flashes. Front occupant and rear row occupant seat belt unfastened warning function can only be triggered when there is occupant on the seat.*

Brake system warning light



With the vehicle powered on, if the brake fluid level is abnormal or the brake system breaks down, the "brake system warning light (red)" will illuminate. Please immediately stop the vehicle safely, and contact Our Service Dealer for service as soon as possible.

ABS (Anti-lock Braking System) warning light



With the vehicle powered on, if the "ABS warning light (yellow)" illuminates while driving, it indicates that the ABS is faulty. Please contact Our Service Dealer for service as soon as possible.

EBD (Electronic Brake Distribution) warning light



With the vehicle powered on, if the "EBD warning light (red)" illuminates while driving, it indicates that the brake system is faulty. Please contact Our Service Dealer for service as soon as possible.

Before You Drive

ESC (Electronic Stability Control) indicator



With the vehicle powered on, the "ESC indicator (yellow)" flashes when the ESC is operating. If the indicator illuminates, it indicates that the electronic stability control system is faulty, please contact Our Service Dealer for service as soon as possible.

ESC (Electronic Stability Control) OFF indicator



With the vehicle powered on, if the ESC OFF switch is pressed to disable the ESC function, the "ESC OFF indicator (yellow)" will illuminate.

See "Brake system" in the Starting and Driving section for more information.

EPB (Electronic Parking Brake) indicator



With the vehicle powered on and the EPB enabled, when the parking brake is applied, the "EPB indicator (red)" will illuminate and immediately go out after the parking brake is fully released.

EPB (Electronic Parking Brake) malfunction indicator



With the vehicle powered on, if the "EPB malfunction indicator (yellow)" illuminates, the brake system is faulty. Please immediately stop the vehicle safely, and contact Our Service Dealer for service as soon as possible.

See "Brake system" in the Starting and Driving section for more information.

AUTO HOLD indicator



With the vehicle powered on and the AUTO HOLD enabled, the "AUTO HOLD indicator (white/gray)" will illuminate; when the AUTO HOLD is activated, the "AUTO HOLD indicator (green)" will illuminate.

AUTO HOLD has memory capacity. When the AUTO HOLD function is turned on and the driver unfastens the seat belt, the "AUTO HOLD indicator (white/gray)" will go out, but the function ON state is still memorized by the AUTO HOLD system. In this case, please fasten the seat belt again to enable the AUTO HOLD function.

With the vehicle powered on and the AUTO HOLD enabled, when the AUTO HOLD function is faulty, the "AUTO HOLD indicator (yellow)" will illuminate.

See "Brake system" in the Starting and Driving section for more information.

HDC (Hill Descent Control) indicator



With the vehicle powered on and the HDC enabled, the "HDC indicator (green)" illuminates. When HDC is activated, the "HDC indicator (green)" flashes.

With the vehicle powered, when the HDC function is faulty, the "HDC indicator (yellow)" will illuminate.

See "Brake system" in the Starting and Driving section for more information.

EPS (Electric Power Steering) system malfunction warning light



With the vehicle powered on, if the "EPS system malfunction warning light (yellow)" illuminates, it indicates that the electric power steering system is in general failure, with the performance decreased, please stop the vehicle as soon as safety permits. If the light stays on after restarting the vehicle and driving for a short moment, please contact Our Service Dealer for service as soon as possible; if the "EPS system malfunction warning light (red)" illuminates, it indicates that the electric power steering system is in serious failure, please immediately stop the vehicle safely, and contact Our Service Dealer for service as soon as possible.

FCW (Forward Collision Warning)/AEB (Automatic Emergency Braking) warning light

Note: It applies to vehicles configured with the FCW and AEB.



With the vehicle powered on, if the FCW/AEB function is not enabled or is faulty, the "FCW/AEB warning light (yellow)" illuminates; if the FCW/AEB function is enabled, the warning light will not illuminate. If the FCW system gives an alarm, the "FCW/AEB warning light (yellow)" flashes; if the AEB function is triggered, the "FCW/AEB warning light (red)" flashes.

See "FCW (Forward Collision Warning) and AEB (Automatic Emergency Braking)" in the Starting and Driving section for more description.

LDW (Lane Departure Warning)/LKA (Lane Keep Assist) /ELK (Emergency Lane Keeping) warning light

Note: It applies to the vehicles with the LDW, LKA and ELK.



With the vehicle powered on, when LDW, LKA and ELK are operating, the "LDW/LKA/ELK warning light (grey)" illuminates.

When LDW, LKA and ELK give an alarm or are triggered, the "LDW /LKA/ELK warning light (yellow)" flashes.

Before You Drive

When LDW, LKA and ELK are disabled, the "LDW/LKA/ELK warning light (yellow)" illuminates.

If the warning light illuminates in yellow when LDW, LKA and ELK are enabled, it indicates that the LDW, LKA and ELK break down. Please contact Our Service Dealer for service as soon as possible.

See "LDW (Lane Departure Warning)/LKA (Lane Keep Assist) /ELK (Emergency Lane Keeping)" in the Starting and Driving section for more description of their functions.

BSD (Blind Spot Detection)/LCA (Lane Change Assist) warning light

Note: *It applies to the vehicles with the BSD and LCA (Blind Spot Assist).*



With the vehicle powered on, if the blind spot assist function is turned off or is faulty, the "BSD/LCA warning light (yellow)" illuminates. If the blind spot assist function is turned on and functioning normally, the "BSD/LCA warning light" will go out.

See "BSD and LCA (Blind Spot Assist)" in the Starting and Driving section for more description of their functions.

ACC (Adaptive Cruise Control) indicators

Note: *It applies to vehicles configured with the ACC.*



With the vehicle powered on, if the ACC system is in standby mode, the "ACC indicator (grey)"

illuminates ; with the ACC enabled, if the ACC system meets the activation conditions, the "ACC indicator (blue)"



illuminates.

See "ACC (Adaptive Cruise Control)" in the Starting and Driving section for more description of cruise function.

ICA (Integrated Cruise Assist) indicators

Note: *It applies to vehicles configured with the ICA.*



With the vehicle powered on and ICA enabled, when the ICA is activated, the "ICA indicator (blue)" illuminates. If ICA is in standby mode, the "ICA indicator (grey)" illuminates.

See "ICA (Integrated Cruise Assist)" in the Starting and Driving section for more description of cruise function.

SLIF (Speed Limit Information Function) indicators

Note: *It applies to vehicles configured with the SLIF system.*



With the vehicle powered on, when a traffic sign is detected, the "SLIF indicator" illuminates. See "SLIF (Speed Limit Information Function)" in the Starting and Driving section for more information.

ISA (Intelligent Speed Limit Assist) indicators

Note: *It applies to vehicles configured with the ISA.*



With the vehicle powered on, when a traffic sign is detected, the "ISA indicator" illuminates. Please slow down to avoid overspeed driving. See "ISA (Intelligent Speed Limit Assist)" in the Starting and Driving section for more information.

Speed limit indicator

Note: *It applies to vehicles configured with the speed limit indicator.*



With the vehicle powered on, when the vehicle speed limit function is enabled, the "speed limit indicator (yellow)" illuminates with sound alarm. When the vehicle speed limit function is disabled, the "speed limit indicator (yellow)" goes out and the sound alarm stops.

Conditional speed limit indicator

Note: *It applies to vehicles configured with the conditional speed limit indicator.*



With the vehicle powered on, when a speed limit sign is detected, the "conditional speed limit indicator" illuminates, please reduce the speed on the road in the corresponding direction to avoid overspeed.

Trailer indicator

Note: *It applies to vehicles configured with the trailer indicator.*



With the vehicle powered on, if the trailer is connected successfully, when the turn signal lamp is turned on, "trailer indicator (green)" on the instrument cluster flashes. When the trailer connection fails, "trailer indicator (green)" on the instrument cluster goes off.

Driver status monitoring reminder indicator

Note: *It applies to vehicles configured with the driver status monitor system.*



With the vehicle powered on and the speed is over 10km/h, "driver status monitoring reminder indicator light

Before You Drive

(yellow/orange/red)" illuminates or flashes, it means that the driver is in distraction/smoking/phone use status. Need to correct the driver behavior to maintain safe driving.

Driver status monitor system malfunction indicator

Note: *It applies to vehicles configured with the driver status monitor system.*



With the vehicle powered on, if the "driver status monitor system malfunction indicator (yellow)" illuminates or flashes, it means that the driver status monitor system is faulty. Contact Our Service Dealer for service as soon as possible.

Driving mode indicators

Note: *It applies to vehicles configured with the two-wheel drive models. Please see "All-terrain system" in Starting and Driving section for the driving mode indicators of four-wheel drive models.*



With the vehicle powered on, when selecting the normal button in the driving mode on the central control screen, the "NORMAL indicator (white/black)" will illuminate, and the vehicle is driven in normal mode. When selecting the economy button in the driving mode on the central control screen, the "ECO indicator (green)" will illuminate, and

the vehicle is driven in economic mode, and the output power of the vehicle's drive motor is relatively weak. When selecting the sport button in the driving mode on the central control screen, the "SPORT indicator (red)" will illuminate, and the vehicle is driven in sport mode, and the output power of the vehicle's drive motor is relatively strong.

Air suspension system indicator

Note: *It is applicable to models with the air suspension system.*



With the vehicle powered on, and the "air suspension system indicator (red)" is on, indicating the current height of the air suspension system.



: The suspension height is normal (0 mm) and applicable to conventional urban road conditions.



: The suspension height is high (+30 mm) and applicable to moderate off-road conditions, such as relatively flat, unpaved surface.



: The suspension height is the maximum (+75 mm) and applicable to deep off-road conditions to improve passability, such as mud, rocky roads, etc.



The suspension height is low (-20 mm) and applicable to medium and high-speed driving conditions.

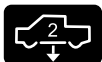

The suspension height is the minimum (-40 mm) and applicable to high-speed driving conditions.

Air suspension system MIL

Note: *It is applicable to models with the air suspension system.*



With the vehicle powered on, when some functions of the air suspension system are limited, the "air suspension system MIL (yellow)" is on; when the functions of the air suspension system are disabled, the "air suspension system MIL (red)" is on. When the air suspension system MIL is on, do not continue driving, otherwise the air suspension may be damaged. Please park the vehicle in a safe place, and contact Our Service Dealer for service.

For more about the air suspension system, see "Air suspension system" in Starting and Driving section.

All-terrain system MIL

Note: *It is applicable to models with the All-terrain system.*



With the vehicle powered on, if "all-terrain system MIL (red)" illuminates or illuminates during driving, it indicates that the all-terrain system is faulty, please contact Our Service Dealer for service as soon as possible.

For more about the all-terrain system, see "All-terrain system" in Starting and Driving section.

CPD OFF indicator light



The CPD function can be turned on or off via a switch on the center control screen. When the function is turned off or the vehicle is powered off, the "CPD function OFF indicator light (yellow)" will illuminate. After turning off the CPD function on the center control screen, the function will be turned on by default the next time the vehicle is powered on.

If you need to turn off the CPD function for a long time, please contact Our Service Dealer. After the CPD function is turned off for a long time, when the vehicle is powered on/off, the "CPD function OFF indicator light (yellow)" on the instrument cluster will illuminate.

Interior discharge indicator

Note: *It applies to vehicles configured with the interior discharge function.*

Before You Drive



When the vehicle is conducting interior discharge operations, the "interior discharge indicator (green)" will illuminate. When the interior discharge has been completed, the indicator will go out. See "Interior discharge" in the Starting and Driving section for more information.

CCO (Crawl Control in Off-road) indicator

Note: *It applies to vehicles configured with the crawl control in off-road system.*



With the vehicle powered on, and CCO enabled, if the CCO system is in standby, the "CCO indicator (white)" will illuminate; when the CCO system is activated, the "CCO indicator (green)" will illuminate. When the CCO system is faulty, the "CCO indicator (yellow)" will illuminate. See "Crawl control in off-road" in the Starting and Driving section for more information.

Exterior lamp switch

Combination lamp control switch

Lamps control switch

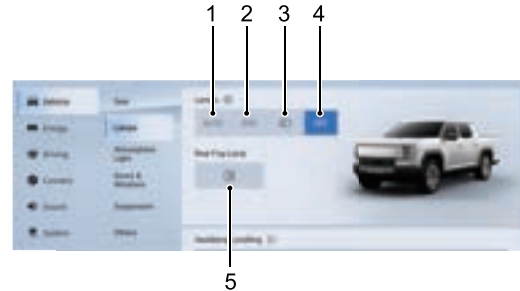



The lamp control switch is on the central control screen. Please operate it through the touch keys on the central control screen. Click the lamp touch button, and the corresponding lamp will light up. The daytime running lamps automatically illuminate after the vehicle is started.

Note: *As the entertainment system software will continue to be updated and iterated, the pictures in this manual are only schematic diagrams, which may be slightly different from this vehicle. They are for reference only, and the actual vehicle status shall prevail.*

1 AUTO: Headlamp control switch. When the headlamp switch is in AUTO position, the headlamps turn on or off according to the ambient lighting. When the vehicle is started and the

Before You Drive

headlamps low beam are not turned on, the daytime running lights will automatically turn on and the rear position lamps will be turned on (when the ambient brightness is high, the rear position lamps will automatically turn off).

- 2 : Position lamps switch. When the headlamp switch is in  position, the following lamps illuminate:
- Position lamps
 - License plate lamps
 - Dashboard lights

Note: When the lamp control switch is in low beam/AUTO/OFF mode, turn on the position lamps mode, pop up a box saying "Please confirm whether to switch to position lamps", click "Yes" to enter the position lamps mode. An audible warning will sound if the headlamp switch is on when the vehicle is powered off.

- 3 : Headlamps low beam switch.

Note: If headlamps are on when the vehicle is parked, the battery will discharge, and the vehicle may be unable to restart due to battery lack of power.



Note: Before the vehicle is powered off, if the headlamp control switch is in AUTO position, the headlamp control switch is still in AUTO position after the vehicle is powered on again.

Note: Before the vehicle is powered off, if the headlamp control switch is in a non AUTO mode and the vehicle has not went to hibernation mode, the front headlight control switch will be in the original mode position after being powered on again; After the vehicle has went to hibernation mode and powered on again, the front headlight control switch is in AUTO mode.

Note: See "Switches on steering column and steering wheel" in this section for more operation methods of turn signals and headlamps.

- 4 OFF : Headlamps OFF switch. When the vehicle is in non P gear, the OFF position is gray and you cannot press the switch; When the vehicle is in P gear, this switch can be pressed. When the vehicle enters non P gear again, the front headlight control switch is in AUTO mode.

Note: When the vehicle is in non P gear, the external lights of the vehicle cannot be turned off, which will affect driving safety. The external lights of the vehicle can only be turned off in P gear.

- 5 : Rear fog lamp switch. When the vehicle is powered on, press the rear fog lamp switch  to turn on the rear fog lamps, synchronously lighting up the low beam and position lamps. When the rear fog lamps are turned on, the "rear fog lamp indicator (yellow)" on the instrument cluster illuminates.

Before You Drive

Note: *Rear fog lamps shall not be used until the visibility is obviously restricted (such as heavy fog or snow).*

Headlamp levelling adjustment

The headlamp levelling adjustment switch is located on the central control screen, please adjust according to the number of passengers. To adjust the height of the headlamps, the headlamps must be turned on.

- High: Only the driver or driver and co driver are present on the vehicle.
- Medium: There are passengers on the rear of the vehicle or they are fully loaded.
- Low/Very Low: The vehicle is loaded with passengers and luggage.

Automatic high beam adjustment

The automatic high beam adjustment switch is located on the central control screen. Please turn on or off the automatic high beam according to driving needs.

Daytime running lamp

Daytime running lamps make it easier for others to see the front of your vehicle clearly during the day.

If your vehicle is equipped with daytime running lamps, the daytime running lamps will illuminate when the vehicle is powered on. When the vehicle is powered off, the daytime running lamps will go out.

Light cover fogging

Under humid or cold weather conditions, or when the vehicle is exposed to rain or after washing, there may be very small water droplets, fine water mist, or white mist (condensation) on the inner surface of the lampshade:

- This situation is due to the normal phenomenon of condensation of water vapor in the high-temperature air inside the vehicle lamp when it cools down.
- When the vehicle is parked in a dry environment, or when the exterior lamps are turned on and the vehicle is in motion, water vapor will gradually evaporate, and there may still be residue at the corners of the lamps.
- This phenomenon will not affect the service life of the vehicle's lighting device, and you do not need to replace the lamp assembly.

Before You Drive

SOS E-call system switch

Note: It applies to vehicles configured with the SOS E-call system switch.

In case of emergency, press the SOS E-call system switch, to send signals to the monitoring platform, which can carry out subsequent rescue work.

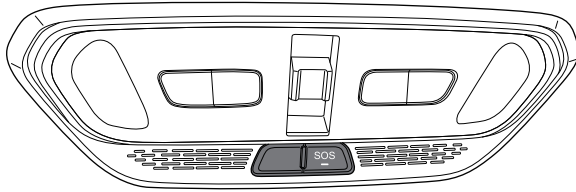

Caution

This switch is for emergency use only, please do not operate it without permission.

Auxiliary fascia console switch

Air suspension system switch

Note: It applies to vehicles configured the air suspension system and all terrain system.

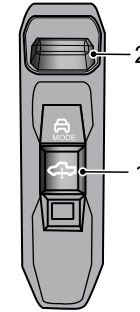

1 Air suspension system switch

2 Air suspension system height toggle switch

See "Air suspension system" in the Starting and Driving section for more instructions.

Before You Drive

All terrain system switch

Note: It applies to vehicles configured the all terrain system.

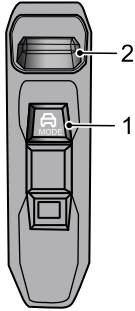

- 1 All terrain system switch
 - 2 All terrain system mode switching toggle switch
- See "All terrain system" in the Starting and Driving section for more instructions.

Switches on steering column and steering wheel

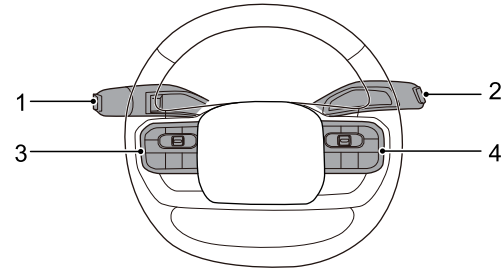

- 1 Wiper and washer, high beam, turn signal lever switch
- 2 Shift lever
- 3 Instrument cluster selection and cruise switch
- 4 Voice control, bluetooth phone, steering wheel heating and custom settings switch

Wiper and washer lever switches

Front windshield wiper and washer

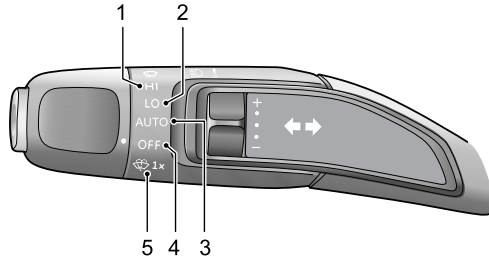

Rotate the lever switch to the desired position.

Position 1—HI: high-speed wipe.

Position 2—LO: low-speed wipe.

Position 3—AUTO: automatic intermittent wipe. The rain sensor detects the rainfall on the windshield and automatically adjusts the wiping frequency of windshield wipers.

Note: Always keep the rain sensor free of dust, dirt or ice.

Position 4—OFF: wiper off.

Position 5— 1x: Washers. Turn the lever switch to the position. The washer will operate immediately. After a short

interval, the wiper will operate with the washer. The washer will be off when the lever switch is released.

Note: The wipers will continue to operate for 3 consecutive wipes after the lever switch is released.

Intermittent wipe/variable interval

 **Worn wiper blades may not clear the windshield properly, thus reducing forward visibility and resulting in accident. Always renew worn wiper blades immediately.**

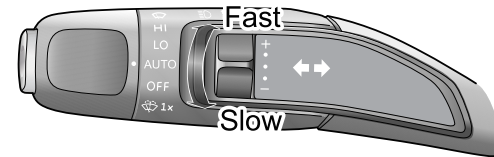

When the lever switch is in AUTO (automatic intermittent wipe) position, move the switch up and down to change the sensitivity of front wipers, and the rain sensor will adjust the wiping rate of front wipers.

Before You Drive

Caution

In freezing or very hot conditions, to prevent damage to the wipers, ensure the blades are not frozen or otherwise adhering to the glass, and clear the screen of obstructions such as snow. Do not operate wipers when the windshield is dry. It can scratch the glass, cause the blades to wear prematurely and obscure vision.

High beam, turn signal lever switch

Turn signals and direction indicators

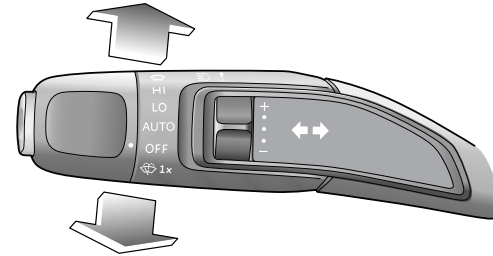

Right turn — push the lever switch upward.

Left turn — pull the lever switch downward.

The appropriate "direction indicators (green)" in the instrument cluster illuminate in time with the turn signals.

Headlamp high and low beams

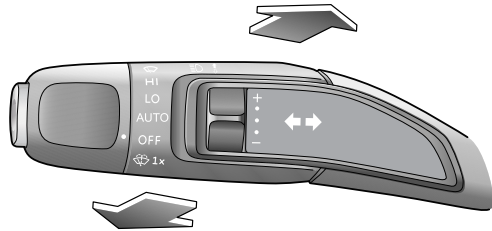

Push the lever switch away from the steering wheel, turn on the high beam, and at this time, the switch will automatically return to its original position; push the lever switch again away from the steering wheel, turn off the high beam, and at this time, the switch will automatically return to its original position.

Note: The "headlamp high beam indicator (blue)" in the instrument cluster illuminates when the headlamps are on high beam. To flash the headlamps, slightly lift the lever switch intermittently towards the steering wheel.

Instrument cluster selection and cruise switch

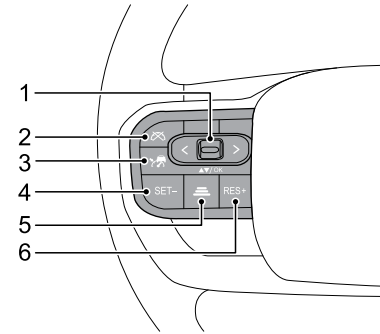

Position 1—  : Instrument cluster selection switch. Press upward, downward, leftward or rightward to page up, page down, page left or page right on the instrument cluster; press OK button to confirm your selection.

ACC (Adaptive Cruise Control)

Position 3—  : Adaptive cruise control switch. If the conditions are met, move the shift lever down to the bottom and release it to activate the ACC (Adaptive Cruise Control) function. To manually deactivate the cruise control, pull up the shift lever or shift the gear, and depress the brake pedal. See "ACC (Adaptive Cruise Control)" in the Starting and Driving section for more descriptions.

Before You Drive

When the adaptive cruise control is activated:

Position 2 - : Adaptive cruise control deactivation switch, short press to deactivate the adaptive cruise control without clearing the set cruise speed.

ICA (Integrated Cruise Assist)

Position 3 - : Integrated cruise assist switch. Move the shift lever down to the bottom and then release to activate the ICA (Integrated Cruise Assist) function. If you need to manually exit cruising, you can pull up the shift lever. See "ICA (Integrated Cruise Assist)" in the Starting and Driving section for more descriptions.

When turning on the ICA:

Position 2 - : ICA cancel switch, short press to deactivate ICA without clearing the set cruise speed.

When the cruise control is activated:



Position 4 - SET-: To decrease the cruise speed.

Position 5 - : Settings of following distance. Adjust the following distance controlled by cruise function, and press it once to switch the following distance from Level 1 to Level 3 cyclically.

Position 6 - RES+: To increase the cruise speed.

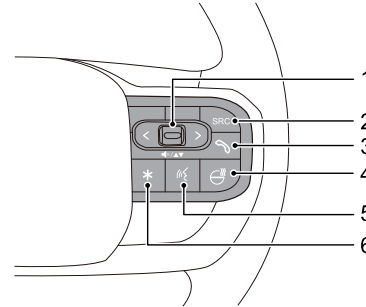
Voice control, bluetooth phone, steering wheel heating and custom settings switch



Position 1 - : Volume control switch. Press upward to increase the volume and downward to decrease; long press to mute; short press , to switch to the previous band/MP3 track; long press to perform fast backward; short press , to switch to the next band; long press to perform fast forward.

Position 2 - SRC: Sound source switching switch. Press SRC switch the radio/MP3 player interface.

Position 3 - : Bluetooth telephone switch. When bluetooth is connected, this switch is the bluetooth phone answering switch. In the general calling state: when there is an incoming call, short press the switch to answer, and long press it to hang up; during the call, short press the switch to hang up, and long press it also to hang up; during the dialing, short press the switch to hang up,

long press it also to hang up. During the call, if there is a call from a third party, short press the switch to hold the current call and answer the new call; long press it to hang up the new call and hold the original call. After the short-press, you can hang up the original call and answer the new call through the soft button on the central control screen.

Automatic closing of vehicle windows during calls

When the mobile phone bluetooth is connected to the vehicle bluetooth, the vehicle windows automatically close when the bluetooth phone is connected or when a call is made.

You can enter the phone settings interface on the central control screen and choose to turn on or off the call automatic window closing function.

Automatic noise reduction of call air conditioning



When the mobile phone bluetooth is connected to the vehicle bluetooth, the air conditioning automatically reduces noise when the bluetooth phone is connected or when a call is made.



You can enter the phone settings interface on the central control screen and choose to turn on or off the automatic noise reduction function of the call air conditioning. After turning on this function, the air conditioning system will automatically lower the air volume when bluetooth phones are connected, reducing the impact of noise.

Note: Please refer to the actual vehicle configuration you purchased for bluetooth function settings.

Position 4—: Steering wheel heating switch. Press this switch to enable the steering wheel heating function, and the indicator illuminates. Press this switch again to disable the steering wheel heating function.

Position 5—: Voice wake-up button. Short press this button to wake up the system voice assistant, long press this button to wake up the phone's connected voice. Please switch based on the specific vehicle model configuration and functions.

Position 6—: Custom settings button. Press the button to enable the custom setting. Please use it according to the different configurations of the entertainment system and related functions which support the custom settings button. Enter the vehicle settings, select from the custom settings button  on the steering wheel (enter/exit 360, map swap between center console and instrument):

- Enter/exit 360: with the  button customized to enter/exit 360, when the conditions are met, short press the button  to enter the 360 screen display on the entertainment mainframe, and short press again to exit the 360 screen display. (This option is only available on the vehicle which is equipped with the 360 around view system and has an entertainment system with a dual screen in the front row)
- Map swap between center console and instrument: with the  button customized to map swap between center console and instrument, when the map application is in the navigation state, short press the button to swap the map information on the center console to the instrument, and short press

Before You Drive

the button * on the steering wheel again to swap the map information on the instrument back to the center console; (This option is only available on the entertainment system with a dual screen in the front row and equipped with internet connectivity configuration)

Note: Please refer to the actual vehicle configuration you purchased for the specific functions of the custom settings switch.

Horn

Regardless of whether the vehicle is powered on or not, press the button, and the horn can work.

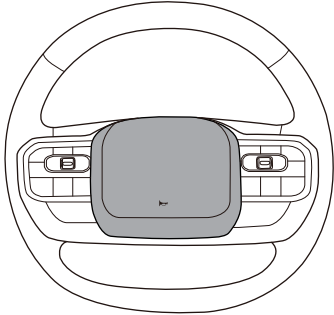

Steering wheel adjustment

⚠ Do not adjust the steering wheel position during driving. This is extremely dangerous.

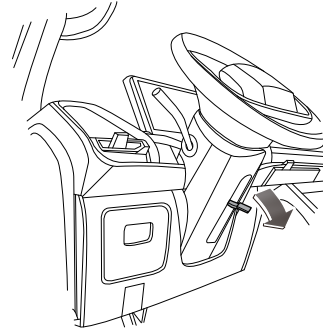

Adjust the steering wheel position to adapt to your driving posture through the following steps:

- 1 Fully release the steering wheel adjusting handle on the steering column downwards.
- 2 Grasp the steering wheel firmly with both hands, and move the steering wheel upward/downward and forward/backward to adjust it to a proper position.
- 3 Select a proper driving position, and pull the steering wheel adjusting handle fully up to lock the steering wheel into its new position.

Heating, ventilation and air conditioning (HVAC)

The air conditioning system cools the air and removes moisture and dust e.g. pollen.

The heating system utilizes high-pressure electronic heater, therefore, the interior air heating function is only available when the vehicle is under high pressure.

The ventilation system ensures the interior ventilation when the vehicle is moving.

The A/C air volume selection button is used to control the air volume.

HVAC is used to control the interior air cooling, heating and ventilation. Fresh air enters the vehicle through the air inlet grille under the windshield and flowing through the A/C filter. Always keep the air inlet grille clean and free of obstructions such as leaves, snow or ice.

Front vents

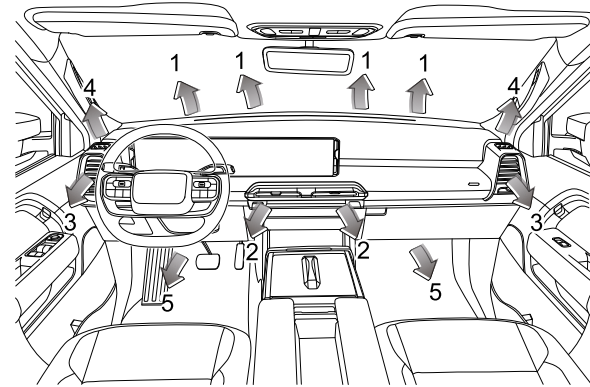

- 1 Windshield vents
- 2 Central vents
- 3 Side vents
- 4 Front door window vents
- 5 Front footwell vents

Before You Drive

Central vents

Move the lever in the central vent upward, downward, leftward and rightward to adjust the direction of the air blowing. Slide the lever in the central vent leftward and rightward to open or close the vent.

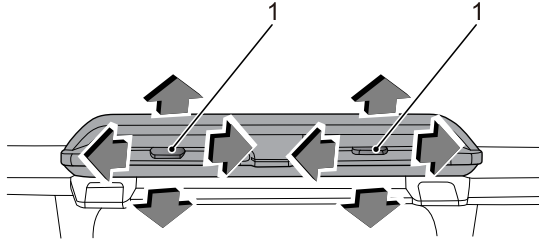

Side vents

Move the lever in the central vent upward, downward, leftward and rightward to adjust the direction of the air blowing. Slide the lever in the central vent leftward and rightward to open or close the vent.

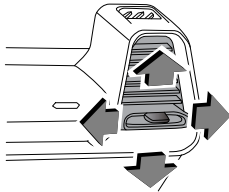

Rear vents

Move the lever in the central vent upward, downward, leftward and rightward to adjust the direction of the air blowing. Slide the lever in the central vent leftward and rightward to open or close the vent.

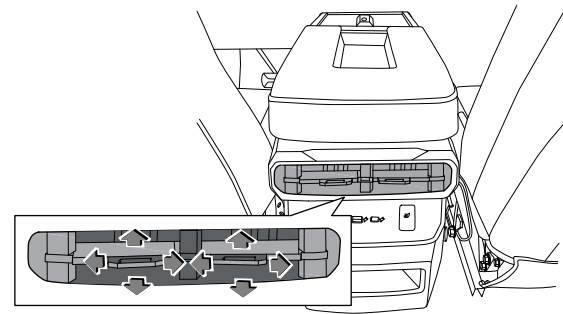

A/C control switch

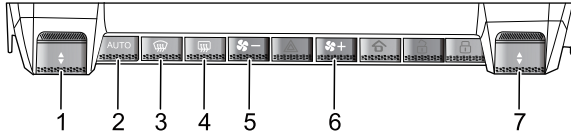

- 1 Left front air conditioning temperature decrease/increase selection lever button
- 2 AUTO button
- 3 Front defrost button
- 4 Rear defrost button
- 5 Front air conditioning air volume reduction button
- 6 Front air conditioning air volume increase button
- 7 Right front air conditioning temperature decrease/increase selection lever button

Front air conditioning temperature decrease/increase selection lever button

Adjust the set temperature of the driver's or passenger side air conditioning.

The temperature selection lever can be moved up and down, and when moved up, the set temperature increases; When toggled down, the set temperature decreases. Set the temperature range to: LO (17 °C), 18 °C - 32 °C, HI (33 °C), adjust the set temperature by 1 °C once, and the corresponding set temperature will be displayed on the central control screen. At LO, it is in the maximum cooling state, and at HI, it is in the maximum heating state.

AUTO button

Automatic air conditioning control button.

Press the AUTO button to enter the full AUTO mode, and all functions will enter automatic working mode. The indicator light on the AUTO switch will light up. At this time, the temperature lever button can be operated according to the needs to set the desired temperature. The air conditioning system will automatically adjust the interior environment of the car according to the set temperature to improve comfort and maintain a constant temperature.

Front defrost button

Switch on the front defrost state.

Before You Drive

When the front defrost button is operated, the corresponding indicator illuminates, A/C is turned on at the same time, and the air outlet mode is switched to defrost; turning on this function has a rapid defrost and defog effect on the front windshield and side glass. In the front defrost state, press the front defrost button or other mode buttons again to exit the defrost state.

Rear defrost button

Switch on the rear defrost state.

When the rear defrost button is operated, the corresponding indicator illuminates, and the rear defrost function is enabled; turning on this function has a rapid defrost and defog effect on the rear windshield.

For vehicles with heated exterior rearview mirrors, the function of heated exterior rearview mirror will be enabled when the Rear Defrost button is pressed, to help remove fog or frost from the surface of the rearview mirror.

Note: The rear defrost will stop after operating for 15 minutes, and its indicator goes off.

Front air conditioning air volume reduction button

When the front air conditioner is turned on, every time the air volume reduction button is pressed, the air volume decreases by one gear. When the air volume is adjusted to one gear, further reduction of the air volume can turn off air condition, and the corresponding air outlet gear status is displayed in the

entertainment system. Long press to gradually reduce the air volume.

When the air conditioning is turned off, the air conditioning can be turned on by operating the air volume adjustment button.

Front air conditioning air volume increase button

When the front air conditioner is turned on, every time the air volume increase button is pressed, the air volume increases by one gear. When the air volume is adjusted to eighth gear, further increase in air volume does not work, and the corresponding air outlet gear status is displayed in the entertainment system. Long press to gradually increase the air volume.

When the air conditioning is turned off, the air conditioning can be turned on by operating the air volume adjustment button.

A/C operation and display interfaces on center console screen

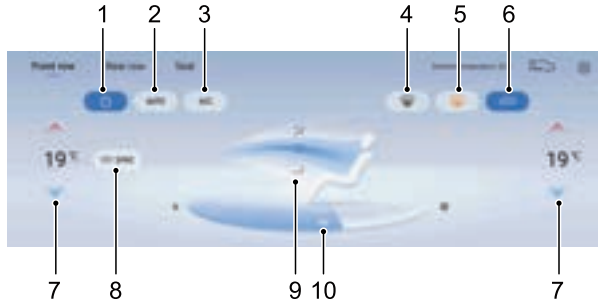

- 1 Power button
- 2 AUTO button
- 3 A/C button
- 4 Front defrost button
- 5 Rear defrost button
- 6 Internal/external circulation button
- 7 Temperature adjusting button
- 8 SYNC button
- 9 Air outlet mode button
- 10 Air volume adjusting button

Note: As the entertainment system software will continue to be updated and iterated, the pictures in this manual are

only schematic diagrams, which may be slightly different from this vehicle. They are for reference only, and the actual vehicle status shall prevail.

Power button

Air conditioning on/off button.

If the indicator illuminates, it indicates that the air conditioner is on, and the air conditioning functions will be enabled according to the status before shutdown; if the indicator goes out, it indicates that the air conditioner is off, and the air blower, compressor and other air conditioning functions are disabled.

Temperature adjusting button

The A/C temperature adjusting button is used to adjust the required temperature of left/right A/C.

In any season, after the air conditioner is turned on, the A/C state will be adjusted as soon as possible, so that the temperature in the vehicle reaches the set temperature and remains stable.

There are 17 gears for temperature selection range; when the temperature is set to LO, the air conditioner is in the highest refrigerating power state; when the temperature is set to HI, the air conditioner is in the highest heating power state.

The set temperature of automatic air conditioner is between 22°C and 24°C, which is the recommended comfortable temperature.

Before You Drive

If brief and continuous switching is performed between different set temperatures, the automatic air conditioner has no adequate time to be adjusted to the set temperature.

SYNC button

Synchronous temperature selection.

When the button illuminates, the set temperature at the front occupant side will be synchronized to the same as that at the driver side; when the temperature at the driver side is adjusted, the temperature at the front occupant side will change with it.

If the temperature at the front occupant side is adjusted individually, the temperature at the driver side will not change with it, the SYNC indicator goes out, and exits the SYNC state.

AUTO button

Turn on the automatic A/C function.

Press the AUTO button to enter the fully automatic state of the air conditioner, and the air volume, mode, circulation and other functions enter the automatic working state. In this case, the temperature adjusting button can be operated as needed for comfort level to set the required temperature, based on which the A/C system will automatically adjust the vehicle environment, in order to reach the target temperature and maintain stability in the vehicle at the maximum speed.

In AUTO state, when the mode, air volume and A/C buttons are operated, the AUTO indicator goes out, the corresponding

functions will exit the AUTO state, and other unoperated functions will remain in auto state.

A/C button

Switch on and off the compressor.

Operate the A/C button to illuminate the corresponding indicator; the air conditioner will turn on the compressor to cool the air in the vehicle, and has a certain dehumidification function.

The A/C indicator is always on in AUTO state (in automatic control state, which does not indicate that it is operating); if the A/C button is operated, A/C will exit the AUTO state and enter the state of manual control.

The compressor can only operate when the motor is operating.

Air outlet mode button

Adjust the air blowing mode.

Air outlet mode is divided into face, footwell and window modes. The corresponding indicator illuminates, indicating that there is air outlet in this direction, and you can freely combine air outlet modes according to needs. It's recommended to blow the face with cool wind in summer, blow the feet with hot wind in winter, and blow the window when there is fog on the front windshield, which is more convenient for improving the comfort level in the vehicle.

Air volume adjusting button

To control the blower speed.

Before You Drive

There are 8 gears for air volume adjusting; air volume can be adjusted according to requirements for comfort level.

When the air conditioner is turned off, the A/C system can be turned on by setting air volume.

Internal/external circulation button

Internal/external circulation is switched through the button.

Operate the button to switch the A/C air inlet mode; external circulation indicates that the air enters the air conditioner from outside, and internal circulation indicates that the air circulates in the vehicle.

Internal circulation is recommended when refrigeration is required; external circulation is recommended when heating is required.

Front defrost button

Switch on the front defrost state.

When the front defrost button is operated, the corresponding indicator illuminates, A/C is turned on at the same time, and the air outlet mode is switched to defrost; turning on this function has a rapid defrost and defog effect on the front windshield and side glass. In the front defrost state, press the front defrost button or other mode buttons again to exit the defrost state.

Rear defrost button

Switch on the rear defrost state.

When the rear defrost button is operated, the corresponding indicator illuminates, and the rear defrost function is enabled; turning on this function has a rapid defrost and defog effect on the rear windshield.

For vehicles with heated exterior rearview mirrors, the function of heated exterior rearview mirror will be enabled when the Rear Defrost button is pressed, to help remove fog or frost from the surface of the rearview mirror.

Note: The rear defrost will stop after operating for 15 minutes, and its indicator goes off.

Automatic defog button

After this function is turned on, the A/C system will automatically adjust its state according to interior humidity and temperature, to avoid fog on the glass inside the vehicle, and the effect will be better after A/C "AUTO" is turned on.

Maximum air volume limit button

After this function is turned on, the A/C system air volume will be limited in "AUTO" and "Front Defrost" modes, with the maximum not exceeding that in 7/6/5 gear.

Automatic fresh air switch time button

After this function is turned on, and internal/external circulation is in "AUTO" state, the A/C system will automatically switch the circulation mode every 10/20/30 minutes, to ensure that interior air is fresh.

Before You Drive

Off-car ventilation button

After this function is turned on, if A/C (compressor) is in working state before vehicle shutdown, the A/C system will turn on the blower again 30s after vehicle shutdown, and continue to blow air for 1 minute and dry the evaporator, to prevent the growth of mold.

Air conditioning operating tips

- If the vehicle has been parked in direct sunlight, open the windows before operating.
- To clear misted windows on rainy days, operate the defrost button, which can decrease the humidity inside the vehicle timely and effectively. This is most effective during rainy weather and high humidity.
- Insufficient cooling may occur when driving in urban stop/start conditions.

Note: If the air conditioning will not be in use for more than one month, run the vehicle at idle speed and turn on the system for more than 10 minutes (once every month, including in winter). This aims to maintain the proper lubrication of the compressor and the seals, so as to extend the service life of the system.

Note: Condensation will be formed on the evaporator when the A/C is operating. So you may find a small pool of water under the vehicle after the vehicle is stopped.

Rearview mirrors

The exterior rearview mirror glasses are convex shaped to broaden the field of view: this makes objects appear smaller and further away than they really are.

Caution

Always check all rearview mirrors for cleanliness and positioning before driving; clean and adjust if necessary.

Exterior rearview mirrors

Power exterior rearview mirrors

Press the left (L) or right (R) switch (Figure 1) to select the exterior rearview mirror on the corresponding side. At the same time, the indicator near the L/R on the selected switch illuminates.

Press four arrows on the round switch (Figure 2), to adjust the angle of exterior rearview mirror.

Press the L or R switch (Figure 1) again, the corresponding indicator goes out, and the adjustment of mirror can be stopped to prevent accidentally modification of adjusted mirror angle.

Before You Drive

Switches of exterior rearview mirror not equipped with power folding function

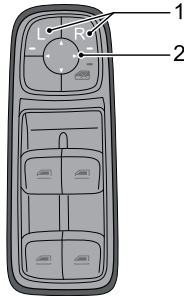

Switches of exterior rearview mirror equipped with power folding function

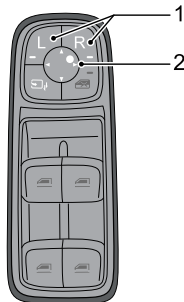

Folding of exterior rearview mirrors

Manual folding of exterior rearview mirrors

To protect the safety of pedestrians, the outside rear view mirrors will rotate to two sides from the normal installation position when suffering a strong impact. Reset the exterior rearview mirrors by applying little pressure onto the mirror frames.

Power folding exterior rearview mirrors

For vehicles equipped with power folding exterior rearview mirrors, it is allowed to fold/unfold exterior rearview mirrors manually/automatically.

- Manual/power folding/unfolding of exterior rearview mirrors

Press the folding switch on the driver side combination switch  (as indicated by the arrow), to automatically fold the exterior rearview mirrors. Press this switch again, to return the mirror frame to its original position.

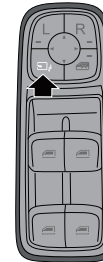

Before You Drive

- Automatic/power folding/unfolding of exterior rearview mirrors

When the exterior rearview mirrors are folded and the vehicle power supply is turned off, the exterior rearview mirrors will be automatically unfolded after the vehicle is unlocked. When the vehicle is unlocked but the doors are not opened, after 30s, the vehicle will be automatically locked again and exterior rearview mirrors will resume to folding state.

When the exterior rearview mirrors are unfolded, the vehicle power supply is turned off, and all doors and front compartment hood are closed, the exterior rearview mirrors will be automatically folded after the vehicle is locked.

The function setting of automatic/power folding exterior rearview mirrors can be conducted through the touch button on the center console screen.

Caution

Both the mirror power adjustment and the power folding of exterior rearview mirrors are operated by power switch, directly operating with hands may cause failures of relevant devices, and directly injecting the high-pressure water column will cause failures of electric device when washing the vehicle.

Heated exterior rearview mirrors

For vehicles with heated exterior rearview mirrors, the exterior rearview mirrors are integrated with heating element, to remove the frost or fog on the mirror. The heating function of mirror is enabled together the rear window heating operation, that is to say, only after the power system is started, when the rear defrost button  is enabled, the heating function of exterior rearview mirrors can function at the same time.

Memory function of exterior rearview mirrors

For vehicles with memory function of exterior rearview mirrors, the memory function of exterior rearview mirrors has 3 gears, bound with the seat memory function; enter the seat interface on the center console screen, to select the driver memory touch button, and adjust the exterior rearview mirrors according to the prompts. Short press the gear switch to select the position of exterior rearview mirrors at this gear.

Exterior rearview mirror 'tilt down in reverse' function

For models equipped with the exterior rearview mirror memory function, the exterior rearview mirror 'tilt down in reverse' function operates as follows:

- 1 Set it in the 'tilt down in reverse' option on the central screen.
- 2 Shift into Reverse gear.
- 3 Adjust the left and right exterior rearview mirrors to the proper position for reversing.

Before You Drive

The next time when the vehicle is shifted into Reverse gear, the mirrors will recall the position memorized during the last reverse, and shifting out of Reverse gear will restore their normal driving positions. If re-adjustment is required, it can be done again by following the above steps.

Caution

You can set the 'tilt down in reverse' settings of Left Side Only, Right Side Only, and Both Sides on the central screen, please choose according to your driving habits.

Interior rearview mirrors

Adjust the interior rearview mirrors, to obtain possible optimum viewing angle. The anti-dazzle function of interior rearview mirrors can reduce the dazzling effect of vehicle headlights behind at night.

Manual anti-dazzle interior rearview mirrors

Move the adjusting handle at the bottom of interior rearview mirrors, to change the viewing angle of rearview mirrors, achieving the anti-dazzle function. Push the adjusting handle back to return the interior rearview mirrors to normal positions.

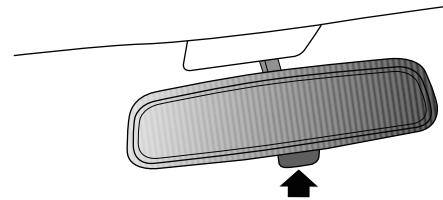

Note: In some situations, using manual anti-dazzle function of interior rearview mirrors will enable the driver to have incorrect judgment of the position of vehicle behind.

Before You Drive

Automatic anti-dazzle interior rearview mirrors

Type 1

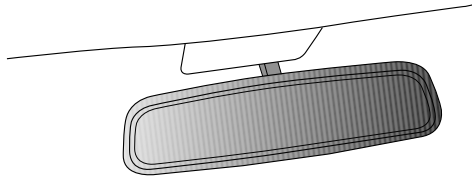

For vehicles with automatic anti-dazzle interior rearview mirrors, after the vehicle is powered on, the automatic anti-dazzle function is automatically enabled, when the driver may be dazzled by the vehicle headlights behind, the light sensor enables the anti-dazzle function. After the vehicle power-off, the automatic anti-dazzle function is turned off.

Automatic anti-dazzle function cannot be enabled normally in the following situations:

- When the light of vehicle behind cannot be directly shed on the light sensor.
- When selecting the reverse gear.

Note: *When the film is applied to the rear window glass, it may affect the usage of automatic anti-dazzle function.*

Type 2

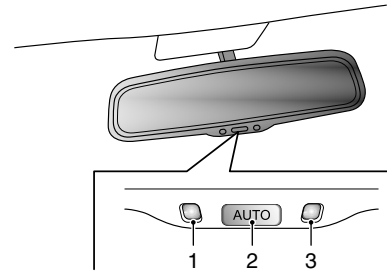

For vehicles with automatic anti-dazzle interior rearview mirrors, after the vehicle is powered on, press the automatic anti-dazzle function switch (2) at the bottom of rearview mirrors, the automatic anti-dazzle function is automatically enabled and the green working indicator (1) illuminates; when the driver may be dazzled by the vehicle headlights behind, the light sensor enables the anti-dazzle function. Press the automatic anti-dazzle function switch (2), the working indicator (1) goes out, and the automatic anti-dazzle function is turned off; press the switch again to re-enable this function.

- 1 Working indicator
- 2 Automatic anti-dazzle function switch
- 3 Light sensor

Automatic anti-dazzle function cannot be enabled normally in the following situations:

- When the light of vehicle behind cannot be directly shed on the light sensor.
- When selecting the reverse gear.

Note: *When the film is applied to the rear window glass, it may affect the usage of automatic anti-dazzle function.*

Streaming media interior rearview mirrors

Streaming media rearview mirrors are to capture the image behind the vehicle in real-time manner through a camera (installed on the rear panel of the vehicle) mounted in the rear of vehicle, and show it on the streaming media interior rearview mirror display without loss and delay. That is to say, observe the real conditions behind the vehicle in the viewing angle of camera. Streaming media rearview mirror can greatly reduce the visual blind spot and improve the driving safety.

For vehicles with streaming media interior rearview mirrors, the streaming media function is enabled after vehicle power-on, to display the image behind the vehicle in a real-time manner.

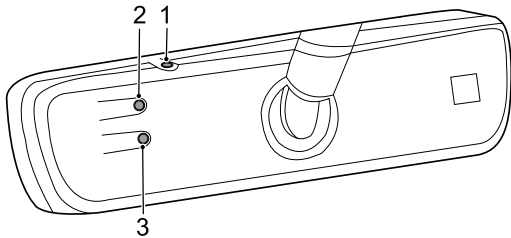

Long press the button (1) to switch the state of automatic anti-dazzle interior rearview mirror and streaming media. In streaming media state, short press the button (1) to enter the operation interface. Streaming media can adjust the visual field and color; visual field adjustment can be used to move images up and down, and adjust the scale of images.

Methods for moving images up and down:

- 1 Short press the button (1) to enter the visual field adjustment column, select the Move Up/Down option, and the color of font changes from blue to red, indicating that the adjustment function has been selected.
- 2 Short press the button (2) and button (3) to move up and down respectively.
- 3 After setting, short press the button (1), and the color of font changes from red to blue, indicating that the Up/Down adjustment function of visual field has been exited; short press the button (1) to exit the setting interface.

Methods for adjusting scale of visual field:

- 1 Short press the button (1) to enter the visual field adjustment column, select the Scale option, and the color of font changes from blue to red, indicating that the adjustment function has been selected.
- 2 Short press the button (2) and button (3) to scale up and down respectively.
- 3 After setting, short press the button (1), and the color of font changes from red to blue, indicating that the scale function

Before You Drive

of visual field has been exited; short press the button (1) to exit the setting interface.

Methods for adjusting color:



- 1 In streaming media state, first adjust it to the Color Adjustment option; short press the button (1) to select and enter the color adjustment function, then the color of font changes from blue to red, indicating the adjustment function has been selected.
- 2 Short press the button (2) and button (3) to make color adjustment of displayed image.
- 3 After setting, short press the button (1), and the color of font changes from red to blue, indicating that the color adjustment function has been exited; short press the button (1) to exit the setting interface.



Interior equipment

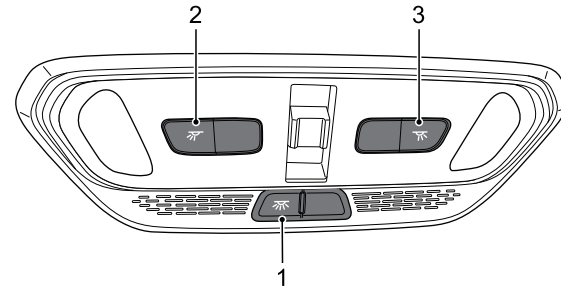

Roof vanity lamp

Front roof vanity lamp





Press the switch (1)  vanity lamps on both sides and rear roof vanity lamp illuminate at the same time; press the switch (1)  again, and the vanity lamps on both sides and rear roof vanity lamp go out at the same time.

Press the switch (2)  , the left vanity lamp illuminates. Press the switch (2)  again, the left vanity lamp goes out.

Press the switch (3)  , the right vanity lamp illuminates. Press the switch (3)  again, the right vanity lamp goes out.

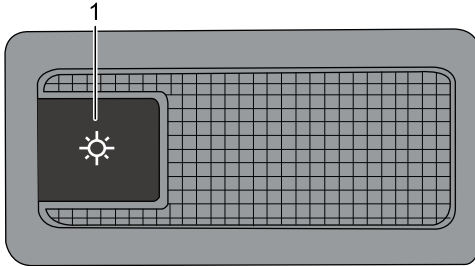
Rear roof vanity lamp



Press the switch (1) , and the rear roof vanity lamp illuminates; press the switch (1)  again, and the rear roof vanity lamp goes out.

Note: *The rear roof vanity lamp will illuminate when any door is opened and will go out automatically about 30s after the door is closed. The roof vanity lamp will go out automatically about 15 minutes after any door is opened to avoid lack of battery power.*

Multi-color atmosphere light

Note: *It applies to vehicles configured with the multi-color atmosphere light. Due to different vehicle configurations, the location and functional scenarios of the atmosphere light on your vehicle should be based on the actual vehicle configuration you purchased.*

The multi-color atmosphere lights are located on the dashboard and front door.

The touch buttons on the central control screen can be used to control the on/off, color, brightness and illumination mode of multi-color atmosphere lights.

Multi-color atmosphere light has several subdivided intelligent scene functions, including: welcome on board, incoming call reminder, etc.

You may set the lighting effects of multi-color atmosphere light for different scenes according to personal preference and lighting requirements, to configure a comfort function and safety alarm function in the vehicle.

Before You Drive

USB ports

USB ports are located on the lower side auxiliary fascia console. The position and type of USB ports on your vehicle shall be subject to the actual configuration of the vehicle you purchased.

Caution

Please do not use the USB port for a long time when the vehicle is powered on but has not started, which may cause the battery to lose power.

Type-C and USB ports located below the front side of the auxiliary fascia console

the USB port can provide charging function and play multi-media files; The Type-C port can provide charging function.

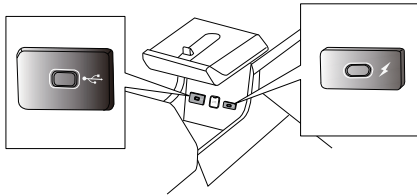

Type-C and USB ports located below the rear side of the auxiliary fascia console

The Type-C and USB ports can provide charging.

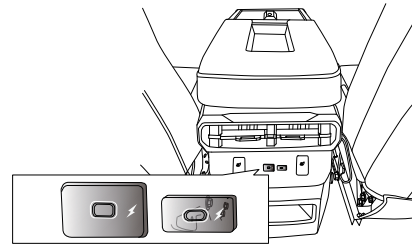

Before You Drive

12V power socket

Note: *It applies to vehicles configured with the 12V power socket.*

The power socket is located at the auxiliary fascia console, which is mainly used for providing power supply connection for external electric devices. The position of 12V power socket on your vehicle shall be subject to the actual configuration of the vehicle you purchased.

Caution

Please do not use the power socket for a long time when the vehicle is powered on but has not started, which may cause the battery to lose power.

Note: *The power socket can provide power supply for electric devices of which power is no more than 120W.*

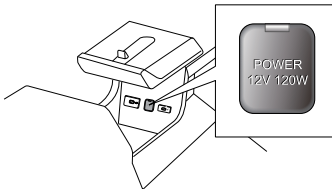

Wireless charging system for mobile phone

Note: *It applies to vehicles configured with the wireless charging system for mobile phone.*

If your vehicle is configured with wireless charging system for mobile phone, then the system will enable mobile phone to be charged wirelessly through electromagnetic induction without wires connected.

Note: *The wireless charging system does not apply to all mobile phones, but only to the "Qi" certified mobile phones.*

Operations for mobile phone wireless charging

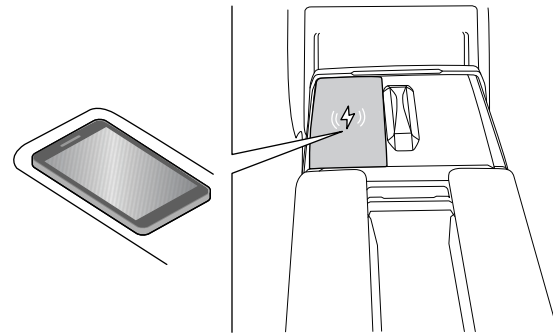

Place the mobile phone as shown in the figure above (with the screen forward), with the center of mobile phone aligned to the charging symbol.

Before You Drive

When the mobile phone is being charged, the status column of center console screen will display the charging status icon (charging completion and charging failure also have their corresponding status display). When the vehicle stalls and doors are opened, if the vehicle detects that the mobile phone is still being charged, the driver will be reminded not to forget the mobile phone through center console screen pop-up window and prompt tone.

Note: *When the low-frequency antenna of PEPS system searches for key, the mobile phone wireless charging module may stop operating.*

Caution

Please do not use the wireless charging system for mobile phone for a long time when the vehicle is powered on but has not started, which may cause the battery to lose power.

Failure of mobile phone wireless charging

In case of any failure during charging, it may be caused by the followings:

- Low voltage of vehicle battery.
- In case of any metal foreign matter within charging area, please move away the mobile phone to check for foreign matter. If there is any, remove it and re-place the mobile phone in the charging area.
- High temperature.
- Internal failure of wireless charging system for mobile phone.

- Failure of mobile phone.

Caution

- When driver is not in the vehicle, please do not place the mobile phone in the vehicle for charging, to avoid potential safety hazards.
- When charging, please do not place coin, key, chip card and other metal foreign matters in the charging area, which may cause the metal to be heated, resulting in charging failure and safety accident.
- Only one mobile phone can be charged each time.
- Do not spill water in the charging area, to prevent water from entering the wireless charger through the gap of rubber mat, resulting in charger failure.
- Mobile phone charging may stop when the temperature is high, and will continue after the temperature drops.

Before You Drive

Glove box

 Do not stow sharp, heavy or dangerous objects in the glove box at the passenger side.

Driving with the glove box open may cause injury in the event of an accident or sudden stop. Keep the glove box closed when driving.

Press the button on the upper left side of glove box to open the glove box (if your vehicle is equipped with a glove box lock, you need to insert the key and turn it counterclockwise to unlock). Close it with a firm push.

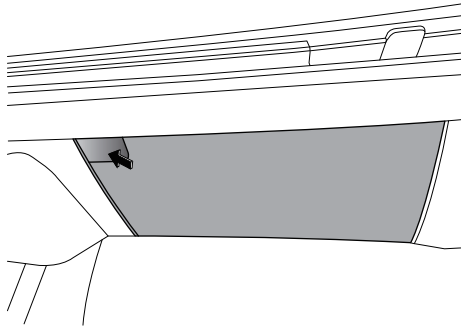

Storage box

Front compartment storage box

The front compartment storage box is located below the front compartment hood. See "Central door locking system" in this section and "Front compartment hood" in Maintenance and Service section for more details about the front compartment unlocking method.

Caution

Please do not exceed 25kg of storage weight.

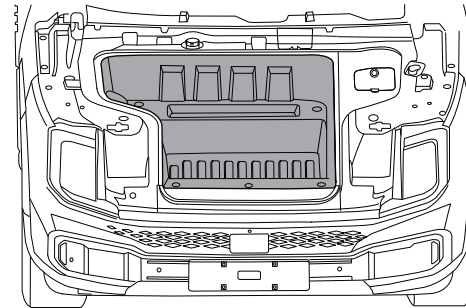

Before You Drive

Storage box on the driver side

It is located below the instrument desk on the driver side, and can be opened by pulling down the storage box buckle.

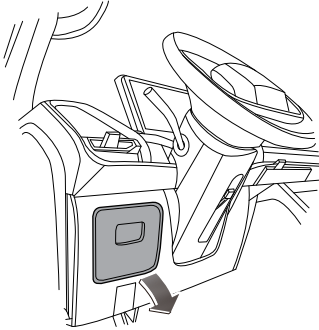

Sun visor and vanity mirror

Both sun visors can be swung up and down to provide a shield through the windshield. Besides, sun visors can be rotated towards side windows.

Turn a sun visor downwards and open the vanity mirror cover. Then you can use the vanity mirror.

Driver's vanity mirror shall be used only when the vehicle stops.

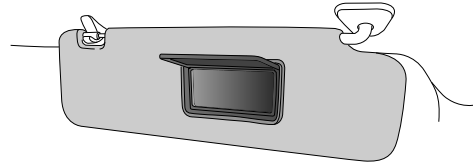

Storage box below the armrest of auxiliary fascia console

Pull up the armrest to open the storage box.

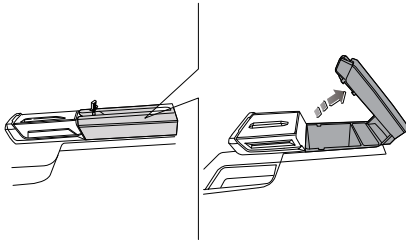

Before You Drive

Vehicle tools

The vehicle tools are placed on the flat floor behind the second-row left seat. For models equipped with the openable rear quarter, the jack is located on the sloping floor behind the second-row left seat, and the other tools are located below the second-row right seat.

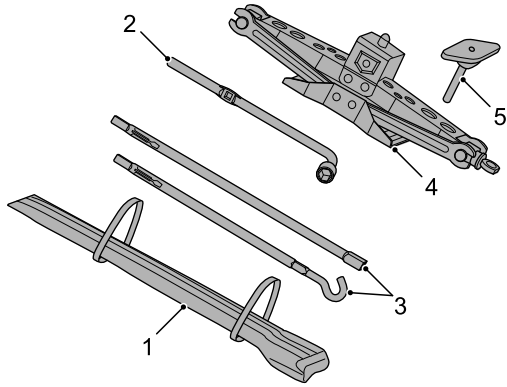

- 1 Vehicle toolkit
- 2 Wheel nut wrench
- 3 Auxiliary rotary post of jack
- 4 Jack
- 5 Retaining bolts for vehicle tools

Safety hammer

Note: It applies to vehicles configured with the safety hammer.

1

The safety hammer is located under the armrest of the auxiliary instrument panel, with one installation quantity. When using the safety hammer in an emergency, knock the four corners and edges of the window glass with the hammer; once the glass cracks, give more knocks to remove the broken glass.

Note: The window adopts tempered glass, the middle part is the most solid part, and the corner and edges are the weakest part. Therefore, please knock the corner and edges of the window glass with the safety hammer.

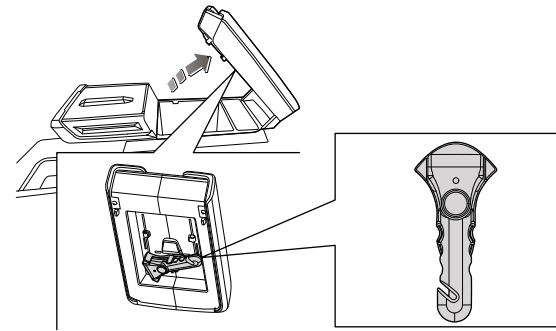

Entertainment system

The contents of this Handbook are simple instructions for the operation of the product. Please read carefully and fully understand the operating instructions accompanied with the entertainment system mainframe before you use this product.



Please do not install or repair your product without authorization.

If the product is installed or repaired by a person who does not receive the training on electronic equipment and auto parts, a dangerous situation may be posed.

According to the relevant national regulations, watching videos and related operations are prohibited when driving, for the personal safety of yourself and others. Please do not watch the screen and perform related operations when driving a vehicle.

Please pay attention to all precautions mentioned in this section of the Handbook and strictly follow the operating instructions.

Never expose the product to any liquid, otherwise short circuit or damage may be caused.

The rear view camera function of the system just serves as a driving assist. Please pay attention to the actual situation.

Caution

- The product shall be kept away from moisture. If the product is started for the first time or reconnected after the disconnection of vehicle power supply, the date shown on each interface of the mainframe needs to be adjusted manually. Be sure to drive safely. Make sure to follow the rules of safe driving and existing traffic regulations.
- Do not operate the product (and the rear view camera function) if it may distract you from safe driving.
- If you have to operate by watching the screen, park the vehicle in a safe place and apply the parking brake.
- Do not set the volume of the product too high, or you will not be able to hear the traffic and emergency signals outside.
- For the sake of safety, some features, such as video playback, will be disabled when driving.
- The system can detect the running speed of the vehicle. When the speed exceeds a certain value, the system will prevent you from watching video while driving. If you want to watch the video, park the vehicle in a safe place and apply the parking brake.
- In order to protect the battery from running out, please make sure to start the vehicle when the system is used.
- The pictures in this Handbook are schematic diagrams which may be slightly different from the real car in details and are for reference only. As for the specific colors and functions of the interface, please refer to the real vehicle.

Before You Drive

1

For the user guide and help of the entertainment system, please follow the following steps to access the related application of the vehicle entertainment system.

Note: As the entertainment system software will continue to be updated and iterated, the pictures in this manual are only schematic diagrams, which may be slightly different from this vehicle. They are for reference only, and the actual vehicle status shall prevail.



1 HOME Button

Short press the HOME button (1) to return to the HOME page from other interfaces; if the current page is the HOME page, this action is invalid.

Long press the HOME button (1) for about 10 seconds to restart the entertainment system.

The use guide and help of the entertainment system are presented on the relevant pages of each function. The specific presentation is as follows:

Click icon **i** to expand the corresponding instructions for the function. The specific style is as follows:



Before You Drive

System update (FOTA)

Note: *It applies to vehicles configured with the system update (FOTA) system.*

You can check the system update status on the [System & Restore] -> [System Update] page.

When your vehicle system needs an update, you can confirm the purpose of this update and choose whether to proceed with the update on the [System & Restore] -> [System Update] page.

Note: *For specific update details, please refer to the official notifications released by SAIC MAXUS Automotive Co.,Ltd.*

Caution

Before updating the system, ensure that the vehicle meets the following conditions. During the update process, the vehicle will be unable to drive, and some functions of the vehicle will be unavailable (such as door locks, remote controls, etc.) until the update is completed. Please choose a suitable time and park the vehicle in a safe place for the update.

- Battery voltage $\geq 12V$.
- Power mode is OFF.
- Vehicle speed $\leq 4\text{km/h}$.
- Vehicle being shifted into Park.
- Parking brake is applied.
- Power system is not ready and the charger is not connected.
- Traction battery SOC $\geq 30\%$.

When the above conditions are met, the vehicle will enter the update preparation state, and the system will start updating after you lock and leave the vehicle in 10 minutes.

Note: *If the system indicates that the update has failed or if any issues occur after the update, please contact Our Service Dealer promptly for consultation and repair.*

Starting and Driving

- 114 Before Starting and Driving
 - 114 Start/stop vehicle
 - 115 PEPS system
 - 117 Driving
 - 118 Gear shift
 - 121 Charging requirement
 - 134 Exterior discharge
 - 136 Interior discharge
 - 138 Low speed alarm module
 - 139 Electric power steering system
 - 140 Braking system
 - 150 Air suspension system
 - 154 ATS (All Terrain System)
 - 157 Four-wheel drive system
 - 158 Crawl control in off-road
 - 160 Parking assist system
 - 164 Driver assistance system
 - 194 Driver state monitoring
 - 195 CPD (Child Presence Detection)
 - 196 Tires
 - 198 Loading
 - 201 Trailer towing
-

Starting and Driving

Before Starting and Driving

- Ensure that the daily/weekly maintenance checks have been done as detailed in the section "Maintenance and Service - Owner's Check".
 - Check that the seat is in the right position.
 - Check that the adjustment of all the rearview mirrors is in place.
 - Check that all lights, signal systems and warning indicators operate normally.
 - Check that all passengers have correctly fastened seat belts.
- With the vehicle is powered on, check that all warning lights and gauges are operating normally (Please see "Warning lights and indicators" in the Before You Drive section).

Caution

Be sure you have read the "Before You Drive" section of this Handbook and a good understanding of your vehicle and its equipment before reading this section.

Start/stop vehicle

Power on vehicle

Unlock the vehicle with key. When the driver door is opened, the vehicle can be powered on automatically.

Start vehicle

The vehicle not started can be started when meeting the following conditions.

- Enter the vehicle with a valid key.
- Step on the brake pedal, and switch the gear to D gear or R gear to start the vehicle ("READY indicator" on the instrument cluster illuminates).

When the front compartment hood is not closed or there is a malfunction, press and hold the brake pedal and press the hazard warning light switch for 5 seconds to start the vehicle ("READY indicator" on the instrument cluster illuminates).

Power off vehicle

The vehicle is stationary, the gear is switched to P, you leave the vehicle, close the driver's door, lock the vehicle, and the vehicle power is turned off.

Caution

- In this scenario, if you enable the “No Power-off for Temporary Parking” mode on the central control screen, then the vehicle will be kept powered on.
- In this scenario, you can also turn off the vehicle power supply through the “Vehicle Power Off” mode in the “Settings” page on the central control screen.

Automatic power off

With the vehicle kept stationary, switch the gear to P gear without stepping on the brake pedal, and the vehicle will automatically be powered off 2 hours later; if the “No Power-off for Temporary Parking” mode is enabled, the vehicle power will not turn off after locking the vehicle.

Emergency power off

When the vehicle is kept stationary, if it needs to be powered off in emergency in case of sudden conditions, please long press the hazard warning light switch for 5s, or press it for 5 consecutive times in 3s to turn off the vehicle power supply.

When the vehicle is running, if it needs to power off the vehicle in emergency in case of sudden conditions, please step on the brake pedal while pressing the hazard warning light switch for 5 consecutive times in 3s to turn off the vehicle power supply.

PEPS system

Keyless unlocking

When all doors are locked, enter the sensing area with a remote key and press the microswitch on the door handle, the central lock will unlock automatically. After unlocking, turn signal lamps will flash twice. If you do not conduct any of the following operations within 30s after that, the central lock will automatically lock again:

- Open any door
- Shift the power supply position to a non-OFF position
- Operate the central lock to unlock/lock

Note: *It is feasible to unlock doors with the central unlocking button on the remote key. Press the central unlocking button once, and the central lock will unlock automatically.*

Keyless locking

When the driver's door or front passenger door is in unlocked state, enter the sensing area with a remote key, and then press the micro switch on the door handle. The direction indicators will flash once, meanwhile the alarm horn will ring once for a short time (as appropriate). Then all doors will be locked, meanwhile the vehicle enters the fortification state. In any of the following cases, the doors will not be locked after the micro switch is pressed:

- The power supply switch is placed in non-OFF position

Starting and Driving

- The remote key is left in the vehicle
- The remote key is not in the sensing range
- The remote key battery is low
- The driver's door is open

Note: *It is feasible to lock doors with the central locking button on the remote key. Press the central locking button once, and the central lock will lock automatically.*

Keyless start

When the key is in the vehicle, the front compartment hood closed, the shift lever in P or N gear, step on the brake pedal to start the vehicle.

Backup starting

When the remote control battery is low, the keyless entry function will fail, but you still can start the vehicle. Open a door with the mechanical key and enter the vehicle. At this time, the system may be in IMMO state and the alarm may be triggered, which is a normal situation.

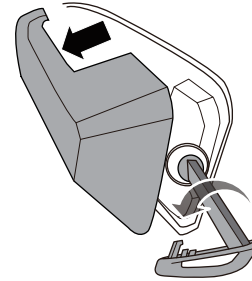

With the shift level in P or N gear, place the remote key on the symbol  which is in the storage box below the armrest of auxiliary fascia console, and step on the brake pedal to start the vehicle. In this case, the system will release IMMO.

Driving



When driving, never place any portable container with fuel on the vehicle. Otherwise it may leak and a fire may result.

When driving on a risky road covered with water, snow, ice, mud, sand, etc., please:

- Slow down, drive with care and reserve longer brake distance.
- Avoid any sudden operation during braking, steering or acceleration.
- Apply sand or other anti-skid material under the drive wheels to provide the traction needed when the vehicle gets stuck in ice, snow or mud.

Skid

If your vehicle skids on a wet road, you cannot control the vehicle due to the decrease of friction force between the road and tires. Different road surfaces, tire inflating pressures and vehicle speeds may lead to skid. Skid is very dangerous.

The optimum method to stop skid is lowering driving speed and keep cautious when you feel the road is wet enough.

Wading driving

In order to avoid damage to your vehicle, when passing a road with gathered water, please:

- Confirm the water depth before the wading driving. The maximum wading depth of the vehicle is 55cm.
- Keep the driving speed lower than the walking speed.
- The wave caused by front vehicle and head-on vehicles may cause the wading depth to exceed the maximum allowed depth.
- To avoid damage to the vehicle, please drive away from the waterlogged road surface as soon as possible.



Water and mud can affect the braking system and lengthen braking distance, leading to an accident!

- Slightly depress the brake pedal to keep brake parts dry and recover performance.
- Do not conduct an emergency brake when passing a slippery road.

Note: The motor, high voltage battery pack, transmission and electronic system of the vehicle may be severely damaged after the vehicle drives on a road with gathered water.

Starting and Driving

Gear shift

Gear

P (Park)

 When parking on a ramp, do not use P gear instead of electronic parking brake. Be sure to stop the vehicle completely before engaging in P gear, otherwise the reducer will be damaged; when the P gear is engaged on the road with more than 20% of ramp, it is necessary to release the brake pedal after the P gear indicator light and the EPB indicator light are on, otherwise the reducer will be damaged; when parking on a road with more than 20% of ramp, do not manually release the EPB (press the EPB release switch on the center control screen) before shifting out of P gear, otherwise the reducer may be damaged.

The vehicle must be stopped completely before shifting to P position.

R (Reverse)

 Completely stop the vehicle before shifting to/out of R (reverse) gear; shifting to R gear during vehicle running will cause retarder damage.

R gear is used for reversing.

When switching to R, it's required to press the brake pedal.

N (Neutral)

 During temporary parking in N position, please set the parking brake or press the brake pedal, otherwise there will be a risk of vehicle slipping or accident. Do not shift into N position while driving.

N gear is a non-power gear, and the transmission system does not transmit power in this gear.

D (Drive)

D gear is a normal forward gear, and you are suggested to use D gear during normal driving. The reducer can adaptively adjust the speed ratio, to achieve the optimum economy.

Starting and Driving

Shift operation

! Situation of the mass surrounding the vehicle especially children must be checked before shifting to D (drive) or R (reverse) gear. Make sure the shift lever is in P (park) position before leaving the driver seat; then apply the parking brake and power off the vehicle.

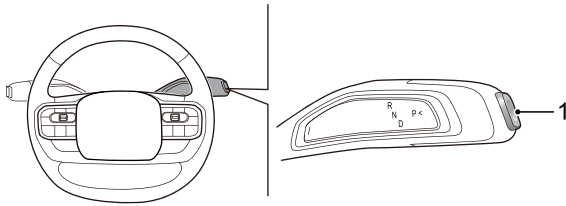

1 P gear button

Shift to P gear

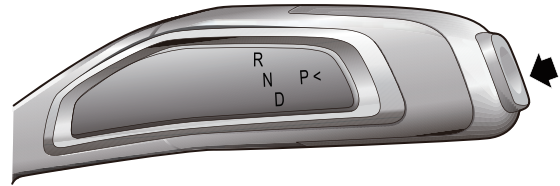

2

When the vehicle is stationary, press the P gear button (1) to engage the P gear.

Starting and Driving

Shift to R, N or D gear

- Current P gear

Press the brake pedal and briefly push/pull the gear lever in the desired direction (two positions each). After releasing the gear lever, the gear lever will return to the middle position.



- Current R gear

When switching from R gear to another gear: It is recommended to press the brake pedal and ensure that the vehicle comes to a complete stop before proceeding.



- Current N gear

When shifting from N gear to R/D gear, please press the brake pedal.



- Current D gear

When shifting from D gear to N gear: It is recommended to stop the vehicle and press the brake pedal.



Caution

ⓘ: When the vehicle is in D gear, push the gear lever up one notch and hold for 1.5 seconds to shift into N gear. When the vehicle is in R gear, pull the gear lever down one notch and hold for 1.5 seconds to shift into N gear. Only when the vehicle is ready, it is allowed to shift into R/D gear.

Auto park (function of automatically returning to P gear)

When the vehicle is in a starting state and the speed is low, the vehicle will automatically switch to P gear when the driver is getting out of the vehicle in D, N, or R gear (the driver's door is opened, the driver's seat belt is released, and the brake pedal is released) to prevent collision and rolling risks. When the vehicle is plugged in with a charging connector for charging, it will also enter P gear.

Note: *When the vehicle is powered off, regardless of the current gear, the vehicle will automatically switch to P gear.*

Charging requirement



Slow charging is generally recommended for the vehicle; frequent use of fast charging should be avoided.

Check will be conducted to confirm whether the inlets and jacks are in good condition or not before charging.

It is recommended that the charging connector should be connected to the charging inlet in the body before operating the charging equipment.

After charging, turn the power of the charging equipment off first, then disconnect the charging connector from the charging inlet in the vehicle body, and close the charging inlet cover as well as the charging port panel on the body.

When the charging pile breaks down, immediately notify the relevant professional, and the operator cannot handle it without authorization.

Charging can be conducted in rainy days, but rainproof measures will be adopted for charging connector and charging port in the process of removing and inserting charging connector.

Charging operation need be stopped in extreme weather such as storm.

Starting and Driving

Requirements for charging equipment

- Insulation resistance $\geq 10M\Omega$.
- As low-voltage platform of the vehicle is 12V, charging pile whose low voltage output is 12V will be used for charging to avoid damaging low voltage equipment of vehicle.
- The charging equipment must meet Standard IEC 62196.

Safety instructions for charging with residential electricity

Basic principles

- Charging pile is not provided for charging with residential electricity. For charging piles purchased by customers themselves, it is recommended being installed by professionals.
- When charging from a household outlet, avoid using other electrical equipment on the same power line.
- Power supply circuit at the customer side shall be evaluated by qualified professionals.

Requirements for electricity leakage protection device

- Electricity leakage protection device shall be used on the power supply circuit at the customer side, and installed at the frontmost end of the power supply circuit.
- High-sensitivity high-speed electricity leakage protection devices with a sensitive current of 30mA or smaller leakage current value are recommended.

Requirements for over-current protector (air switch)

- Over-current protector must be installed on the power supply circuit, behind and close to the electricity leakage protection device.

Starting and Driving

Requirements for circuit cable

- Power supply circuit at the customer side must be a special circuit, and circuit wiring shall conform to the related requirements for building and electricity.
- For old buildings, it is recommended arranging new special circuit.
- The diameter of power supply circuit cable at the customer side shall be no less than 4 sq.mm and the total length of cable shall be no more than 50 m.
- Circuit wiring shall avoid the humid or water logged area and be free of flammable substances around.

Requirements for household socket outlet

- Socket must be arranged in positions convenient for vehicle parking and charging operation.
- Standard 220V/16A (Users in German standard area or in Israel standard area) AC power sockets are recommended.
- The wiring of the socket should be correct (live wire, neutral wire and earth wire), and the earth wire should be reliably earthed.
- Transfers using adapters, reels, power strips, etc. are prohibited.
- The socket must be protected from rain, sun and foreign objects, and there is no heat source around.
- The socket shall conform to the requirements of IEC 60884, and be reliable in quality.

Miscellaneous

- After the battery is fully charged, disconnect the charging cable; if it is needed to actively stop the charging, first disconnect the charging connector from the vehicle, and remove the plug at the power supply side.
- During charging operation in rainy days, rain shall be avoided from entering the charging connector and inlet.
- Check the connector/inlet for deformation, blackening or ablation before each charge, and replace it immediately if any abnormal condition is found. Even if there is no abnormal condition, if it is used for over 3 years, replace it with a new one.
- If there is peculiar smell, smoking, overheating or other abnormal conditions during charging, immediately turn off the charging circuit, stop the charging operation and check the connector and inlet.
- If the over-temperature fault lamp for charging cable illuminates, check the connector/inlet for deformation, blackening or ablation, and replace it immediately if any abnormal condition is found.

Starting and Driving

Requirements for charging environment

- Spark may be generated in some modules of charging equipment. To avoid accident, do not conduct charging operation in gas station and places where there are inflammable gases or liquid.
- Charging operation time will be affected by external temperature. Charging time will be extended at low temperatures.

Influence of charging operation on special personnel

When conducting fast charging, the operation area may have magnetic field interference. It is recommended that users who carry implantable heart pacemaker and implantable angiocardy defibrillator keep away from vehicles under charging.

Magnetic field interference may affect normal effect of electronic medical equipment such as implantable heart pacemaker and implantable angiocardy defibrillator. Users who carry implantable heart pacemaker and implantable angiocardy defibrillator may be injured or die.

If you carry implantable heart pacemaker and implantable angiocardy defibrillator, please guarantee when vehicle is under charging operation:

- Don't stay in the vehicle.
- Don't enter into the vehicle for taking objects in the passenger compartment.

Note: *When the vehicle does not conduct charging operation, special personnel can ride and drive vehicles.*

Starting and Driving

Charging mode

Charging pile DC charging (fast charging)

Use the public DC charging piles to charge your vehicle.

Please refer to the following table and attached drawings. The **K** label on the vehicle charging port indicates that the vehicle supports the fast charging shown in the following table.

Household single-phase AC charging (slow charging)

Connect the vehicle to a household standard household socket to charge the vehicle, if the socket is not well grounded, the charging device will have a failure prompt for unable to charge. You need to contact a professional electrician to repair the ground wire or connect it to a well-grounded socket for charging. Check the power socket in the process of charging. If it is hot, do not continue to use it. Contact a qualified electrician for servicing the power socket.

Always use the standard household socket which meets the provisions in IEC 60884 for charging.

If a 'Electric Leakage' prompt is displayed, contact a professional electrician to check the insulation status of the hot wire or the neutral wire.

Special power sockets should be selected for battery charging, as they can prevent line damage and protection trip caused by high-power charging from affecting the normal use of other equipment. Over time, the power socket may wear out due to

normal use and may even be damaged, making it no longer suitable for charging an electric vehicle.

When used outdoors, plug it into a power socket that is protected from rain.

Charging pile AC charging (slow charging)

Use the public AC charging piles to charge your vehicle.

Please refer to the following table and attached drawings. The **C** label on the vehicle charging port indicates that the vehicle supports the slow charging shown in the following table.

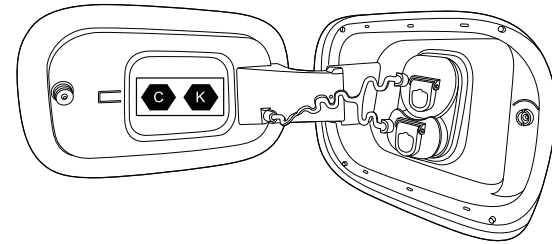

Configuration	Type of accessory	Voltage range	Identifier
TYPE 2	Vehicle inlet	≤480V RMS	C
FF	Vehicle inlet	50V ~ 500V	K

Starting and Driving

Fast charging

Note: *Fast charging should be conducted by the personnel in the fast charging station according to the operation instructions for charging pile.*

To perform a fast charging for the vehicle, turn off the vehicle power, wait for 3 ~ 5 minutes, and then follow the instructions below:

- 1 Select a standard DC charging connector that matches your vehicle.
- 2 The charging port is at the left rear side of the vehicle. Gently press the right side of the charging port panel by hand to open the panel.

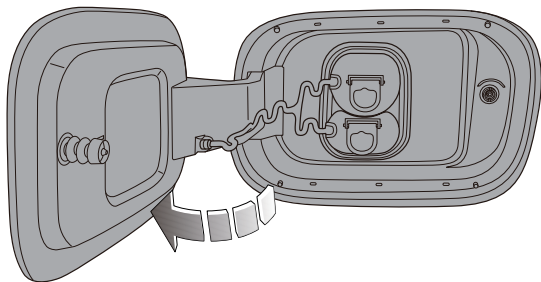

- 3 Open the cover on the charging inlet.

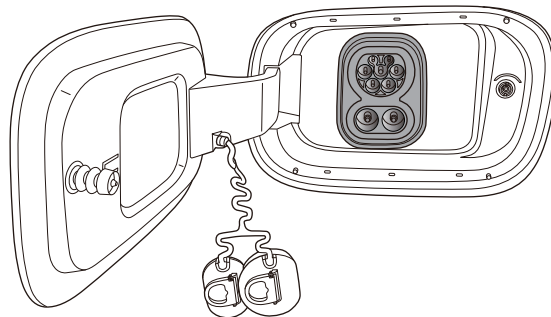

- 4 Remove the DC charging connector from the charging pile.
- 5 Connect the charging connector with the charging socket, and lock the connection of the charging connector and charging socket using the locking mechanism on the charging connector handle.
- 6 Connect the charging connector to the charging equipment, and turn the power of the charging equipment on according to the instructions on the charging pile.

Note: *Before charging, check whether there is any abnormality in the charging equipment. In the charging process, the "charging status indicator (yellow)" on the instrument cluster illuminates. If the equipment can not be charged after 3 consecutive attempts, it is*

Starting and Driving

recommended to replace other equipment for attempts. If the equipment can be charged after replacement, the previous charging equipment may be damaged.

Note: Please check whether the PP and CP pins of the charging connector are rusted. If so, please clean them before charging to prevent charging failure.

- 7 After the charging connector is properly connected, the "charging connection indicator (red)" on the instrument cluster will come on.

Note: Please make sure that the charging connector is fully inserted into the charging stand to avoid that the electronic lock cannot be locked, resulting in charging failure, as shown below.

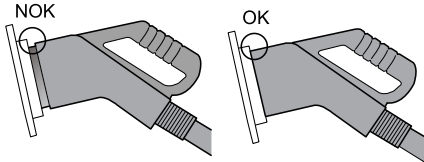

- 8 In the charging process, the "charging status indicator (yellow)" on the instrument cluster illuminates.

- 9 Upon completion of charging, the "charging status indicator (yellow)" goes out. Please turn the power of the charging equipment off before removing the charging connector.

- 10 Close the cover on the charging inlet.

- 11 Close the charging port panel.

Caution

Select a standard DC charging pile or charging equipment that matches your vehicle. Once the battery is fully charged, the battery management system will have an automatic calibration function. If the vehicle has been shallowly charged (less than 99%) every two or three times, you need to fully charge (100%) the vehicle once.

2

Starting and Driving

Slow charging

There are three ways to slow charge. The charging method on your vehicle depends on the actual configuration of your vehicle.

- 1 Mode 2 charging is shown in the figure below. One end of the charging in this mode is connected to the household socket and the other end is connected to the vehicle. (This connector is optional for users)

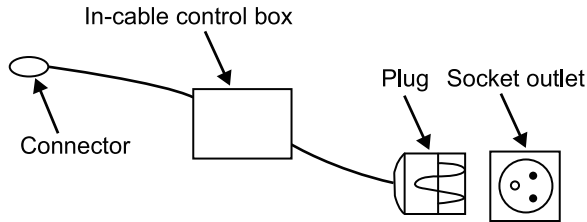

The LED words on the In-cable control box are as follows:

Charging status	Status description			
	Power (Green)	Charging (Red)	Fault (Red)	Complete (Green)
Initial state	On	Flash	Flash	Flash
To be connected	On	On	Off	Off
Normal charging	On	Off	Off	On
Charging completed	On	Off	Off	On

Power-on self-test failed	On	Off	Flash	Off
Abnormal communication	On	On	Flash	Off
Over/under voltage	On	Off	On	Off
Ungrounded	On	Off	On	Flash
Over current	On	Flash	On	Off
Current leakage	On	Off	Flash	Flash
Over temperature	On	On	On	On

- 2 Mode 3 charging is shown in the figure below. One end of the charging in this mode is connected to the charging piles and the other end is connected to the vehicle. (This connector is optional for users)

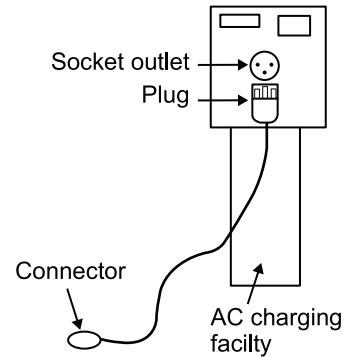

Starting and Driving

3 Direct charging with charging post.

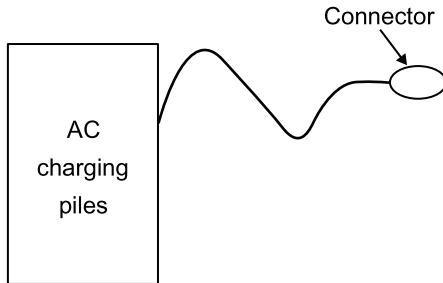

Note: Slow charging is a way of charging high-voltage battery pack to reach the optimal equilibrium state.

To perform a slow charging for the vehicle, turn off the vehicle power, wait for 3 ~ 5 minutes, and then follow the instructions below:

- 1 Select the standard 16A socket (German standard socket or Israel standard socket) with reliable earthing or AC charging piles.
 - German standard socket.

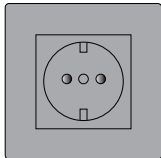

- Israel standard socket.

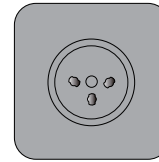

- 2 Take the charging connector out from its package.
- 3 Insert the AC input cable plug of the charging connector into the socket or AC charging piles.
- 4 The charging port is at the left rear side of the vehicle. Gently press the right side of the charging port panel by hand to open the panel.

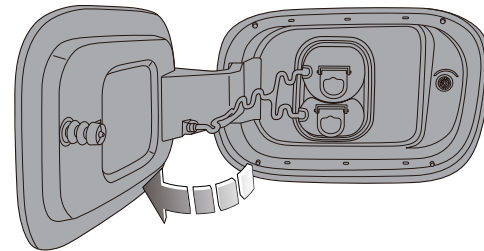

2

Starting and Driving

- 5 Open the cover on the charging inlet.

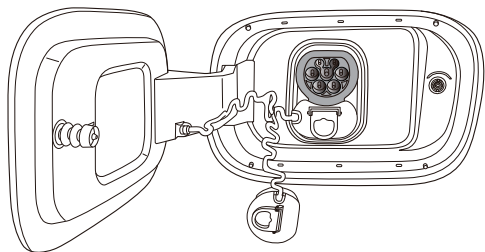

- 6 Connect the charging connector to the charging inlet.

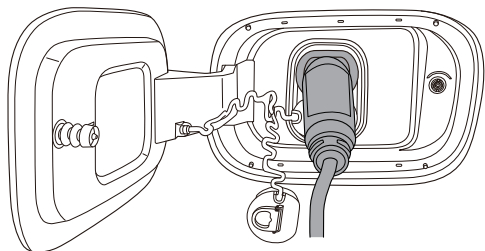

- 7 After the charging connector is properly connected, the "charging connection indicator (red)" on the instrument cluster comes on and the electronic lock of the charging inlet is enabled, which guarantees that the charging connector will not be unplugged whilst charging.

Note: Please make sure that the charging connector is fully inserted into the charging stand to avoid that the electronic lock cannot be locked, resulting in charging failure.

- 8 After the above operations are completed, the system will be charged automatically within about 20 seconds.
- 9 During charging, the "charging status indicator (yellow)" on the instrument cluster is on.

Note: If charging with a public AC charging pile, connect the charging connector to the charging equipment, and charge according to the instructions on the AC charging pile.

Note: If charging with a public AC charging pile, before charging, check whether there is any abnormality in the charging equipment. In the charging process, the "charging status indicator (yellow)" on the instrument cluster illuminates. If the equipment cannot be charged after 3 consecutive attempts, it is recommended to replace other equipment for attempts. If the equipment can be charged after replacement, the previous charging equipment may be damaged.

Note: If charging with a public AC charging pile, please check whether the PP and CP pins of the charging connector are rusted. If so, please clean them before charging to prevent charging failure.

Starting and Driving

- 10 Once the battery is fully charged, the "charging status indicator (yellow)" on the instrument cluster will go out, and the electronic lock of the charging socket will be unlocked automatically. Press the button switch on the charging connector to remove the charging connector.

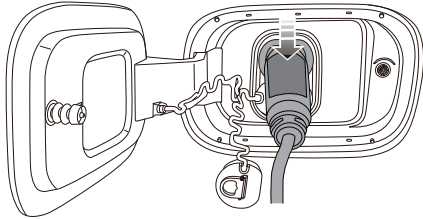

Note: If the charging needs to be ended early and the charging connector be removed, unlock the vehicle with the key, and the vehicle will stop charging automatically. The "Charging status indicator lamp (yellow)" will go out, and the electronic lock will be unlocked automatically. Then, press the button switch on the charging connector to remove it within 1 minute (if the charging connector is not removed within 1 minute, the electronic lock of the charging port will be re-locked).

- 11 Close the cover on the charging inlet.
12 Close the charging port panel.
13 Put the charging connector back into its package.

Caution

Emergency treatment: In the event of an emergency such as fire, smoke or burnt smell, turn the socket power switch off immediately to completely power off the system. If the vehicle has been shallowly charged (less than 99%) every two or three times, you need to fully charge (100%) the vehicle once.

Caution

- If any unidentified foreign matters are found in the charging plug, insulator, pin and socket, the charging process shall be terminated immediately.
- It is strictly prohibited to insert the charging plug and charging base obliquely.
- It is strictly prohibited to shake the charging plug up, down, left and right when inserting / pulling it out, and it must be inserted / pulled out with vertical force.
- During charging, the cable of charging plug must be smoothed, and it is not allowed to distort to force the charging connector seat during use.
- During the charging process, in case of extremely severe weather such as typhoon, rainstorm and hail, the charging process shall be terminated immediately.
- During the charging process, if the charging interface continuously emits strong and irritating odor, the charging process shall be terminated immediately.

Starting and Driving

Charging inlet emergency cable

The AC charging socket is provided with the electronic lock function. In the charging process, in order to prevent children from touching or unplugging the charging connector by accident, after the charging connector is plugged into the charging socket, the electronic lock in the charging socket will be locked following the master control switch. At this time, do not unplug the charging connector forcefully to avoid causing damage. Be sure to unlock it using a key or master control switch before unplugging. If the charging connector cannot be unlocked with a key or master control switch in an emergency, unlock the charging connector by horizontally pulling the emergency cable under the carpet under the left seat in the second row backwards.

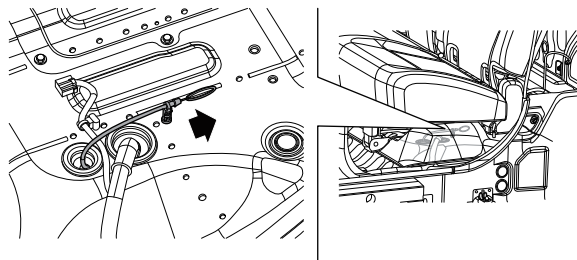

Charging information

Rated charging voltage	Charging power	Charging stand standard	Slow charging standard	Fast charging standard	Anti theft of slow charging connector
Max. 470V	Max. 130kW	CCS2	IEC61851	DIN70121	Anti theft

Equalizing charge

Equalizing charging means that during the charging process, under the action of the battery management system, the voltage of each cell is basically the same, so as to ensure the overall performance of the high-voltage battery pack. Therefore, it is recommended to charge the vehicle at least once a month with a slow full charge of less than 25% of its battery capacity to improve battery performance and lifespan.

Note: For charging safety reasons, the upper limit of DC fast charging capacity is 97%, and the upper limit of AC slow charging capacity is 100%.

Charging appointment

Note: *It applies to vehicles configured with the charging appointment function.*

Charging appointment refers to the user carries out the slow charging at a specified time. The charging appointment function requires that the function of charging piles is available. Some charging piles do not open the appointment for charging due to the consideration of operational efficiency. In case of brand piles that cannot be appointed for charging, please contact the customer service of the charging piles for consultation or our Service Dealer.

For use of charging appointment function, please follow the following steps:

- 1 Turn on the charging appointment switch, and set the charging appointment time.
- 2 Authorize (swiping card, scanning QR code, etc.) after inserting the charging connector.

Caution

- Due to the compatibility of some charging piles, if you mistakenly perform Step 2 and then Step 1, the appointment will fail. It is recommended to perform Step 2 again after unplugging the charging connector.
- If it's required to conduct charging with public AC charging pile during non-appointment time, please turn off the charging appointment switch.

Charging time

Charging time of high-voltage battery pack is related to many factors, such as current electric quantity, charging mode, ambient temperature and charging device power.

Fast charging time

Under the normal temperature state, if the charging equipment has an output capacity of over 130 kW, it will take about 40 minutes to charge the high-voltage battery from 20% to 80%.

Caution

- At a low temperature and in an extremely high temperature environment, the required charging time will be extended.
- If the output capacity of charging device is insufficient, the required charging time will be extended.

Note: *In order to protect the high voltage-battery pack and to speed up the temperature rise of the battery, when performing a fast charge in a low temperature environment, the high voltage-battery pack may have a drop in capacity for a short period of time, it is normal.*

Starting and Driving

Slow charging time

Under the normal temperature state, it takes about 9.5 hours from the alarm state (the low high-voltage battery pack warning lamp on the instrument cluster illuminates) to the full charge state.

Caution

- At a low temperature, the required charging time will be extended. If the air conditioner and other high-power electrical appliances are turned on during slow charging at low temperature, it may result in power level drop and the charging time will be extended accordingly, so the use of air conditioners and other high-power electrical appliances shall be minimized during slow charging.
- If it is not fully charged for a long time, it may lead to inaccurate estimation of driving range, and the charging time required for recharging may be extended.
- After long-term parking, the vehicle needs to be fully charged before its first use, and the charging time may be extended.

Note: *The slow charging time mentioned above means the time required by the vehicle to use AC charging pile for charging. When the residential electricity is used for charging, corresponding charging time will be about 2.5 times of that required for adopting AC charging pile.*

Exterior discharge

Note: *It applies to vehicles configured with the exterior discharge function.*

Discharge requirements

- Only the slow charging inlet(i.e. AC charging inlet) can be used for discharge.
- Check whether the socket and jack are in good condition before discharge. Do not discharge with a discharger that is damaged, rusted, damp or has foreign objects. Do not discharge with a discharge port that is stained by water. Do not discharge with discharge connector and discharge inlet that are deformed, blackened or ablated.
- It is recommended that the discharge connector should be connected to the discharge inlet(i.e. AC charge inlet) in the body before operating the central control screen.
- In the process of discharge operation, surrounding personnel cannot contact operators, vehicle and discharger.
- The vehicle will perform discharge power protection depending on the discharger specifications. Be careful not to use a high-power electrical appliance that exceeds the discharger specifications or use multiple electrical appliances with high power at the same time. During use, please observe the discharge parameters displayed on the meter. When the discharge function is stopped due to protection, unplug the electrical appliance and try again.

- After discharge, turn off the electric appliance first, then disconnect the discharge connector from the vehicle's AC charge inlet, and close the plastic cover of the charge inlet and the charging port door on the body.
- When the charge inlet fails, immediately notify the relevant professional, and the operator cannot handle it without authorisation.
- Discharge can be conducted in rainy days, but rainproof measures shall be taken for discharge connector and discharge port and socket in the process of removing and inserting discharger.
- Discharge operation needs be stopped in extreme weather such as storm.

Requirements for discharge environment

The discharger and electrical appliances may cause sparks during discharge. In order to avoid accidents, do not discharge at gas stations or places with inflammable gases or liquids.

Discharge operation

Follow the instructions below during discharge:

- 1 Please select a discharger with a Rc resistance of $470\ \Omega/1\text{k}\Omega/2\text{k}\Omega/2.7\text{k}\Omega$ for the discharge connector.
- 2 The discharge port is the AC charging inlet for slow charging operations of vehicles. The charging port is at the left rear side of the vehicle. Gently press the right side of the charging port panel by hand to open the panel.

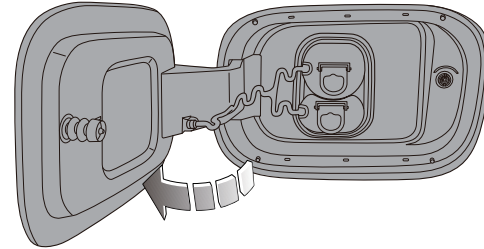

- 3 Open the cover of the discharge inlet, i.e. the cover on the AC charge inlet of the vehicle.

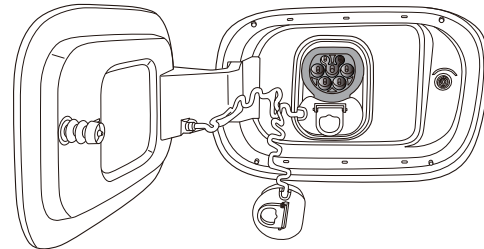

- 4 Connect the discharge connector to the discharge inlet.
- 5 After the discharge connector is connected, click on the application list on the central control screen to enter the Energy Management exterior discharge interface. After

Starting and Driving

setting the battery discharge cut-off level, click on the Start Discharge icon.

- 6 After the above operations, the system will start discharge within 20s.
- 7 To end the discharge, click on the application list on the central control screen to enter the Energy Management exterior discharge interface, and click on the Stop Discharge icon.
- 8 Unlock the vehicle, remove the discharge connector, cover the cover of the discharge inlet (i.e. AC charging inlet), and close the charging port door.

Note: *When the battery power is discharged to the set cut-off level, the discharging will be automatically turned off.*

Caution

Emergency response: If an emergency such as fire, smoke or burnt odor is found during use, turn off the discharge switch immediately to fully cut off the system.

Interior discharge

Note: *It applies to vehicles configured with the interior discharge function.*

Discharge requirements

- Check whether the socket and jack are in good condition before discharge. Do not discharge with a discharger that is damaged, rusted, loose, damp or has foreign objects. Do not discharge with a discharge socket that is stained by water. Do not discharge with a discharge socket or plug that is deformed, blackened or ablated.
- It is recommended to connect the plug of an electrical appliance to the interior discharge socket before operating the entertainment system display.
- After discharge, turn off the electrical appliance, then unplug the electrical appliance from the interior discharge socket, and replace the plastic cover of the discharge socket.
- When the discharge socket fails, Our Service Dealer should be notified immediately to repair it, and the operator should not handle it without authorization.
- The maximum rated discharge current of a single discharge socket is 10A. Be careful not to use a high-power electrical appliance or use multiple electrical appliances with high power at the same time. When the current is too high, the vehicle will stop the interior discharge for protection.
- Ensure that the vehicle is started before interior discharge.

Starting and Driving

Requirements for discharge environment

The discharger and electrical appliances may cause sparks during discharge. In order to avoid accidents, do not discharge at gas stations or places with inflammable gases or liquids.

Discharge operation

Follow the instructions below during discharge:

- 1 The internal discharge socket is located in the front compartment storage box and on the right rear of the cargo box. Please refer to the actual vehicle configuration you purchased for the location of the discharge socket inside your vehicle.
 - Discharge socket inside the front compartment storage box

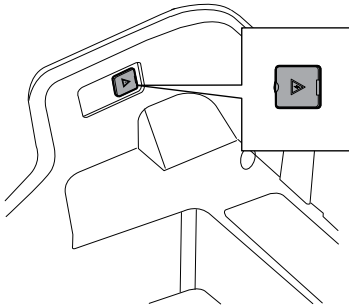

- Discharge socket at the right rear of the cargo box

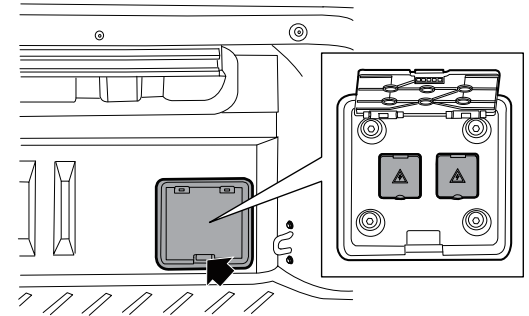

- 2 Open the protective cover of the interior discharge socket.
- 3 Connect the plug of the electrical appliance to be used to the interior discharge socket.
- 4 After connection, enter Interior Discharge in Energy Management on the central control screen. After setting the battery discharge cutoff power, tap the Start Discharge icon.
- 5 After the above operations, the system will start discharge within 20s. After entering the discharge, the indicator light on the discharge socket will light up.
- 6 To end the discharge, tap to enter Energy Management via the app list on the central control screen, and tap the Stop Discharge icon.
- 7 Unplug the electrical appliance and cover the cover of the discharge socket.

Starting and Driving

Note: When the battery power is discharged to the set cut-off level, the discharging will be automatically turned off. The power-off delay after power-down option on the central control screen allows you to select the operation duration of the interior discharge after the vehicle power is turned off, and the optional duration is from 1 hour to 24 hours; after the setting is completed, the interior discharge function will maintain its working state in the set period of time after the power is turned off; the default setting is: when the set period of time is 0 hour or de-energized after power off; then if the vehicle power is turned off, the interior discharge function will be automatically turned off; when the vehicle power is reset to ON, this setting will be restored to the default state. When the vehicle power is turned off, the interior discharge function will be turned off automatically when the set period of time or the set cut-off level is reached, please note to reserve a certain range of discharging power when setting. When the vehicle is connected to the charge connector/discharge connector, it is unable to turn on and use the internal discharge.

Caution

Emergency response: If an emergency such as fire, smoke or burnt odor is found during use, turn off the discharge switch and then unplug the electrical appliance immediately to fully cut off the system. When the temperature is less than -20 °C, the total interior discharge current should not exceed 10A to avoid over discharging the battery.

Low speed alarm module

The pure electric vehicle is quiet in low speed driving, resulting in the probability of accidents occurring to pedestrians (especially the blind) higher than that of conventional vehicles. A system making a warning or prompt sound at low speed is achieved via a low speed alarm module (Acoustic Vehicle Alerting System, AVAS) to reduce the probability of accidents occurring to pedestrians. The design of acoustic warning and sound effects for the sound sensitivity of different populations achieves the balance between safety guarantee and noise pollution.

Low speed alarm sound effect

When the vehicle speed is 0 ~ 20km/h, the low speed alarm module simulates the sound of running engine to make the sound alarm, and the tone gradually increases with the acceleration and vice versa, to warn persons outside the vehicle about the vehicle passing. The minimum average frequency shift speed of the frequency meets the requirements of no less than 0.8%/(km/h).

Note: When the vehicle speed is 0km/h, the low speed alarm module does not make a prompt sound.

When the vehicle is reversing, the low speed alarm module simulates the sound of running engine to warn persons outside the vehicle about the reversing state, and the tone gradually increases with the acceleration and vice versa.

Note: When the vehicle reversing speed is 0km/h, the low speed alarm module does not make a prompt sound.

Electric power steering system

 **If the electric power steering fails or cannot operate, the steering will appear very heavy, which will affect driving safety.**

The electric power steering system only works when the vehicle is started. The system operates via a motor with assistance levels automatically adjusted based on vehicle speed, steering torque and steering wheel angle.

The electric power steering system has the advantages of simple structure and energy saving. Compared with the traditional hydraulic power steering system, the electric power steering system only needs energy in actual steering, so that power loss can be reduced in this operating way of power consumption according to the need.

Caution

When the electric power steering system operates, holding the steering wheel on full lock for long periods will result in a reduction in power assistance and cause a heavier feel to the steering.

Starting and Driving

EPS (Electric Power Steering) system malfunction warning light

See "Warning lights and indicators" in Before You Drive section.

If the battery is disconnected or lacks power seriously, this light may illuminate. At this point, fully turn the steering wheel to the left then the right, finally return to the middle position, thus the system initialization is completed, and the light will go out.

Electric power steering mode

You can set the electric power steering mode in the central control screen, and the steering feel can be selected from standard, sporty, and comfortable.

- Standard: The steering wheel has moderate steering force and is suitable for general driving habits.
- Sport: The steering assistance is reduced, and the steering wheel turns more steadily.
- Comfortable: With increased steering assistance, the steering wheel turns more easily.

Note: To ensure driving safety, the electric power steering mode cannot be switched during the vehicle's steering process, activation of the driving assistance system, or when the driving speed exceeds 55km/h.

Braking system

Service brake

Dual brake hydraulic system

 A failure in one of the hydraulic pipelines will be indicated by illumination of the "braking system

warning light (red)"  on the instrument cluster while driving; it will result in increased brake pedal travel and effort, longer braking distance and may cause the vehicle to pull to one side. Do not pump the brake pedal in an attempt to restore pedal pressure. If there is pressure failure in one of the brake pipelines, the cause must be investigated. **IMMEDIATELY** bring the vehicle carefully to a halt. **Immediately contact Our Service Dealer for service. Do NOT continue driving.**

Should one of the hydraulic pipelines fail the other circuit will continue to function.

Starting and Driving

General state

 Always ensure that floor mats or other objects do not disturb brake pedal movement.

Never rest your foot on the brake pedal as this may overheat the brakes, reduce their efficiency and cause excessive wear. If brake pads/shoes have worn excessively, a squealing or screeching noise will be heard when the brakes are applied, and braking efficiency will be affected. Contact Our Service Dealer for service as soon as possible.

If the motor stops running due to some causes, brake booster will stop working after 2 pedal operations; to achieve the expected brake effect, a larger force shall be applied on the pedal. In these circumstances the braking distance may be longer.

If the vehicle is not in regular use or is garaged for long periods, the efficiency of the braking system could be impaired. Contact Our Service Dealer for service as soon as possible.

Wet state

 Driving in heavy rain and slushy roads will considerably reduce braking efficiency. At this time, keep safe distance from other vehicles and gently depress the brake pedal intermittently to dry the brake friction components. In severe wet weather, this drying process may need to be repeated every few miles.

In winter, ice can form or salt may accumulate on the brake pads and discs. Ice and salt accumulation will be cleaned off after intermittently light applications of the brake pedal.

Descending steep hills

 Overheating the brakes will reduce braking efficiency and may also cause the vehicle to pull to one side.

Starting and Driving

ABS (Anti-lock Braking System)

ABS is used to prevent the road wheels from locking under emergency braking, thereby helping you maintain steering control. No special driving technique is needed.

Under normal braking (where sufficient road surface friction exists to prevent wheel lock), the ABS will not be activated.

An integral feature of this braking system is Electronic Brake Distribution (EBD), which is used to optimize the braking force at the rear wheels under full load condition.

Important rules for emergency brake with ABS On:

- 1 Fully depress the brake pedal.
- 2 Bypass the obstacle. No matter how much brake force is used, you can always maintain the control on direction.

ABS Function



ABS may not be able to shorten the brake distance, depending on road surface conditions, brake distance may vary significantly. In fact, when the vehicle without ABS drives on some roads (e.g., gravel road or snowy road), the brake distance may be shorter.

ABS cannot overcome the physical limitations of stopping your vehicle in too short a distance, cornering at high speed, or aquaplaning, i.e. where a layer of water prevents adequate contact between the tires and the road surface.

ABS must never tempt you to take risks that could affect your safety or that of other road users. You still have a duty to drive within normal safety margins, having due consideration for the road surface, weather and traffic conditions.

If the braking force you use exceeds the available adhesion between the tires and the road, causing one or more wheels to be locked, then ABS will automatically come into operation. You will hear the sound of a rapid pulsation which will also be felt through the brake pedal.

When braking in an emergency, always depress full force to the brake pedal, even if the road surface is slippery. ABS is activated; it constantly monitors the speed of each wheel and

Starting and Driving

varies the braking pressure to each according to the amount of friction available.

This prevents the wheels from locking and enables steering control to be maintained.

Precautions for driving a vehicle with ABS

- In an emergency braking situation, depress full force to the brake pedal.
- Under normal braking, apply steady pressure to the brake pedal - DO NOT PUMP IT.
- Remember that steering control will always be available during braking.
- The availability of ABS does not eliminate the dangers of driving too close to the vehicle in front, aquaplaning, excessive cornering speeds, etc.
- ABS does NOT guarantee shorter braking distances.
- Do not be alarmed if you hear and feel a pulsing at the brake pedal. This is normal and indicates that the ABS is in operation.

ESC (Electronic Stability Control)

Functions of ESC

ESC covers the functions of ABS, EBD, TCS, VDC, HBA, RMI, HHC, AUTO HOLD and HDC.

ESC indicator on the instrument cluster flashes when the ESC is operating. You may hear some noise or feel the vibration of brake pedal, which is normal.

When the vehicle is powered on, "ESC indicator (yellow)"



will illuminate and go off after several seconds. In normal driving conditions, ESC indicator keeps off, and ESC is in monitoring state. When the ESC indicator flashes, it indicates ESC is operating. You may hear some noise or feel the vibration of brake pedal, which is a normal phenomenon. In case of ESC failure, ESC indicator will stay On. Please take the vehicle to Our Service Dealer for ESC inspection.

ESC switch is located on the central control screen, ESC can be turned off with ESC OFF button, and when ESC function is

turned off, "ESC OFF indicator (yellow)"



illuminates and only ABS and EBD functions are available.

EBD (Electronic Brake-force Distribution)

EBD automatically detects the grip conditions between wheels and ground, distributes the brake force optimally to 4 wheels, so as to improve brake efficiency and driving stability.

Starting and Driving

TCS (Traction Control System)

TCS automatically controls the driving force at the start-off and acceleration to prevent wheels from spinning, so as to maintain the driving stability.

VDC (Vehicle Dynamics Control)

VDC is an advanced computer system, which can help you to control the vehicle driving direction in severe driving conditions. When the computer detects the deviation between the expected driving route and the actual driving direction, VDC system may selectively apply brake pressure on one or more brakes of the vehicle so as to keep the vehicle driving in the direction commanded.

HBA (Hydraulic Brake Assist)

In case of emergency braking, usually the driver can step on the brake pedal quickly, but the braking force may not reach the maximum deceleration that the vehicle and the ground can provide. HBA function supports to provide additional braking force in such emergency braking conditions.

RMI (Roll Movement Intervention)

RMI can identify the vehicle rollover trend as early as possible by monitoring the turning angle of steering wheel and lateral acceleration, and apply braking to one or more wheels to prevent the rollover to the greatest extent.

HHC hill hold control

When the vehicle drives uphill, HHC can prevent the vehicle from sliding backwards after the driver releases the brake pedal. An interval up to 2 seconds is available for the driver to shift his foot from the brake pedal to the accelerator pedal so as to successfully drive off on a slope.

AUTO HOLD

The ESC runs together with the EPB to help your vehicle park in any stationary condition without depressing the brake pedal all the time.

HDC (Hill Descent Control)

When the vehicle is running downhill, the HDC function can help the driver keep the speed constant, allowing the driver to focus just on the steering wheel.

Precautions for driving a vehicle with ESC

ESC can detect and analyze vehicle conditions, and take preventive measures by correcting wrong driving operation. However, anything has its limit and no safety device is absolutely safe if the driver blindly drives the vehicle over-speeding.

EPB (Electrical Parking Brake)

The EPB pull-up switch is integrated with the P gear button on the shift lever. When the vehicle is at a standstill, press the P button, the EPB is applied when the vehicle is shifted into P gear, and the EPB is released when the brake is applied and the EPB release button on the center control screen is pressed.

Instructions before using EPB

- Once the vehicle is powered on, the EPB can be used all the time. Do not operate the EPB switch repeatedly when the vehicle is not running to prevent excessive discharging of the battery. EPB is unable to be applied or released when the battery power is insufficient.
- The EPB can prevent accidental slipping when starting off on a slope. The EPB will automatically release only when the vehicle traction is greater than the sliding force.
- When the normal brake of the vehicle fails, the emergency braking function can still stop the vehicle. See "Emergency braking function" in this section for details.
- Minor noise may be heard when applying or releasing the electronic parking brake. This is normal, please rest assured.
- When the vehicle is powered off, the applied parking brake cannot be released, and the released parking brake cannot be applied, please connect an external power supply.
- If the "EPB indicator (red)"  does not turn on or off when you operate the EPB switch, or the "EPB malfunction

indicator (yellow)"  illuminates and the EPB cannot be released through normal operation, please contact Our Service Dealer.

- Do not perform EPB on the road with the slope more than 30%, otherwise the vehicle may slip. If the EPB fails to fully brake when parking on the road beyond a defined slope, the driver can stop the vehicle from sliding by depressing the brake pedal.

Parking

Manual hold

- 1 The vehicle is powered on or the motor is operating.
- 2 Keep the vehicle stationary.
- 3 Press the P gear button on the shift lever and apply the parking brake. If the "EPB indicator (red)" on the instrument cluster illuminates, the parking brake is applied successfully.
- 4 Move the shift lever in P gear when parking.
- 5 When the vehicle is on a slope, please turn the steering wheel to ensure that the vehicle is aimed at the curb when it slips.

Note: When the vehicle is parked on a slope, please hold the brake pedal and press the P gear button on the shift lever to activate the electronic parking brake. Wait for the "EPB indicator (red)" on the instrument cluster to light up before releasing the brake pedal.

Starting and Driving

Start-off

Manual release of EPB

- 1 Power on the vehicle.
- 2 Press the EPB release switch on the center console screen.
- 3 Turn off EPB switch to release the parking brake. If the "EPB indicator (red)" on the instrument cluster goes out, the parking brake is released.

Automatic release of EPB



If a gear is engaged when the vehicle is stopped and the motor is running, never depress the accelerator pedal. Otherwise, the vehicle will immediately move on its own and an accident may occur.

- 1 Power on the vehicle.
- 2 The driver fastens his/her seat belt.
- 3 The transmission is in any gear.
- 4 Depress the accelerator pedal. When starting off on a level ground or a slope, depress the accelerator pedal. When the traction is greater than the sliding force, the parking brake will automatically release, the "EPB indicator (red)" on the instrument cluster will go out, and the vehicle starts to move.

Emergency braking function

When the vehicle is in motion, press the P gear button on the shift lever to activate the emergency braking function. At this time, the

vehicle will brake four wheels by activating the hydraulic brake system, and its braking effect is just like pressing the brake pedal hard. As long as the P gear button is released, the emergency braking function will be deactivated.

Caution

This function is used when the normal braking operation has failed.

Automatic EPB pull-up function

EPB (Electronic Parking Brake) has flameout power-off automatic pull-up function. You can select to enable the EPB power-off automatic pull-up function on the central control screen by the switch titled "Flameout Automatic Electronic Handbrake Pull-up".

This function is enabled by default, that is, EPB will be automatically pulled up when the vehicle is powered off in flameout state. If you select to disable this function, it will take effect only in current ignition cycle. In next ignition cycle, this function will automatically restore as enabled.

When this function is disabled, you need to power off in P gear to ensure that EPB will not be automatically pulled up. Refer to the following processes for the operation steps:

- 1 Park the vehicle stably and engage in P gear;
- 2 Click the button on the central control screen to release EPB;

Starting and Driving

- 3 Click the button on the central control screen to disable the function;
- 4 Shut down the vehicle and power off, lock the vehicle and get off.

Caution

When the function is disabled, be sure to park the vehicle on flat ground to ensure safe parking.

AUTO HOLD

AUTO HOLD switch is located on central control screen. Use this switch to control the on or off of AUTO HOLD system.

The AUTO HOLD system supports the driver to reduce driving fatigue when the vehicle often encounters traffic lights or stops and goes repeatedly. The Auto Hold function enables the parking brake to release automatically when starting off, and the vehicle to park automatically when it is stationary.

2

AUTO HOLD ON

Caution

These conditions may be required to enable AUTO HOLD function: the driver's door is closed; the driver's seat belt is fastened; the motor is started.

When the AUTO HOLD switch is turned on, the "AUTO HOLD

indicator (white/gray)"  on the instrument cluster will illuminate. When the vehicle is stationary and the "AUTO HOLD indicator (green)" on the instrument cluster illuminates, if AUTO HOLD is operating, first perform ESC to hold pressure and stop vehicle. 10 minutes later, if the vehicle is still in stationary state, ESC will request for EPB. The "AUTO HOLD indicator

(white/gray)" goes out, and the "EPB indicator (red)"  illuminates.

Starting and Driving

During operation of the AUTO HOLD, opening the door or unfastening the seat belt will activate the EPB. The "AUTO HOLD indicator (white/gray)" goes out and the "EPB indicator (red)" illuminates.

If you depress the accelerator pedal as usual, the parking brake will be automatically released and the vehicle will start. The "AUTO HOLD indicator (white/gray)" on the instrument cluster illuminates, and the AUTO HOLD is in standby state.

Disable AUTO HOLD

When the AUTO HOLD switch is turned off, the "AUTO HOLD indicator (white/gray)" on the instrument cluster will go out, and the AUTO HOLD function is disabled.

 **Do not perform auto hold on the road with the slope more than 30%, otherwise the vehicle may slip.**

When the "AUTO HOLD indicator (yellow)"  on the instrument cluster illuminates, it means the AUTO HOLD system is faulty, please drive immediately to Our Service Dealer for vehicle inspection.

HDC (Hill Descent Control)

When driving on a long downhill road with a relatively great gradient, if the vehicle speed is within a certain speed range, there is no need for the driver to depress the brake pedal and accelerator pedal, and the vehicle will run at a low speed

automatically, so as to ensure the vehicle goes downhill steadily; at this time, the driver can correct the automatically controlled speed of system through brake pedal and accelerator pedal.

HDC is located on central control screen. Use this switch to control the on or off of HDC system.

When the vehicle speed is within the range of 35 - 60 km/h, HDC is inoperative but in standby state.

When the vehicle speed is higher than 60 km/h, HDC function automatically exits. To enable it again, you need to press the HDC switch on central control screen again.

When the vehicle is powered on, HDC function is disabled by default. When the HDC switch is turned on, "HDC indicator

(green)"  on the instrument cluster illuminates, and HDC function is in standby state. When HDC operates, "HDC indicator (green)" will flash; if "HDC indicator (yellow)" illuminates, it indicates the HDC system is faulty. Please drive the vehicle to Our Service Dealer for ESC system inspection. When the HDC switch is turned off, the "HDC indicator (green)" on the instrument cluster will go out, and the HDC function is disabled.

Note: *HDC function is used to assist the driver to go downhill steadily at a low speed, and it is not recommended to enable this function on a non-ramp road.*

Warning lights

Warning lights related to braking system include "braking system warning light (red)", "ABS warning light (yellow)", "EBD warning light (red)", "ESC indicator (yellow)", "ESC OFF indicator (yellow)", "EPB indicator (red)", "EPB malfunction warning light (yellow)", "AUTO HOLD indicator (white/gray)", "AUTO HOLD indicator (green)", "AUTO HOLD indicator (yellow)", "HDC indicator (green)" and "HDC indicator (yellow)", please see "Warning lights and indicators" in Before You Drive section.

MCB (Multi Collision Brake)

When a vehicle experiences a certain degree of collision, this function can actively brake to prevent or reduce subsequent impacts, reducing the probability and severity of secondary collisions.

Brake pedal sensing mode switching function

The vehicles with electronic control booster is preset with two brake pedal sensing mode: "standard" and "sports", and the driver can select and switch between these two modes on the central control screen.

When the "sports" modes is selected, a small pedal force or pedal stroke can not only obtain larger braking force, but also reach the maximum point of booster force in a short time and shorten the braking distance. This mode is applicable to old or female drivers with small stepping force.

When the "standard" mode is selected, the braking force output is relatively moderate at the same pedal force or pedal stroke, which is applicable to the vast majority of people.

Note: When switching brake pedal sensing mode, ensure that the vehicle starts from a stationary state and the brake pedal cannot be stepped on.

Starting and Driving

Air suspension system

Note: It applies to vehicles configured with the air suspension system.

By continuously monitoring the current driving mode, speed, etc., the air suspension system can provide intelligent control of the body height to improve the comfort, maneuverability, passability and off-road performance of the vehicle.

! When some functions of the air suspension system are limited, the "Air suspension system MIL (yellow)"



on the instrument cluster is on; when the functions of the air suspension system are disabled,



the "Air suspension system MIL (red)" on the instrument cluster is on.

When the Air Suspension System MIL on the instrument cluster is on, do not continue driving, otherwise the air suspension may be damaged. Please park the vehicle in a safe place, and contact Our Service Dealer for service.

Air suspension system height setting

The air suspension system has 5 levels of height, and the vehicle current air suspension system height is displayed in the instrument.

- Max. (+75 mm) : The "Air suspension system indicator



(green)" on the instrument cluster is on, which is applicable to deep off-road conditions to improve passability, such as mud, rocky roads, etc.

- High (+30 mm) : The "Air suspension system indicator



(green)" on the instrument cluster is on, which is applicable to moderate off-road conditions, such as relatively flat, unpaved surface.

- Normal (0 mm) : The "Air suspension system indicator



(green)" on the instrument cluster is on, which is applicable to conventional urban road conditions.

- Low (-20 mm) : The "Air suspension system indicator (green)"

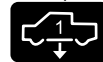

on the instrument cluster is on, which is applicable to medium and high-speed driving conditions.

- Min. (-40 mm) : The "Air suspension system indicator

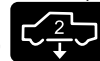

(green)" on the instrument cluster is on, which is applicable to high-speed driving conditions.

Note: Before raising and lowering the suspension, be sure to leave enough space above and below the vehicle to prevent bumping into the vehicle.

Starting and Driving

After the vehicle is started, the suspension may be automatically adjusted to the appropriate height. Please pay attention to the space above and below the vehicle.

When the electronic parking brake (EPB) is applied and the brake pedal is released, switching the height will be easier.

When the suspension system is working, a "tick" sound of the solenoid valve, the exhaust sound or the compressor working sound, and the sound of the suspension lifting and lowering will be heard at the rear of the vehicle, which is normal.

The suspension height will change with the speed. When the speed is greater than a certain value, the suspension will automatically drop to a certain height to improve driving safety and economy. When the speed is less than a certain value, the suspension will automatically rise to a certain height to improve passability.

When the vehicle load changes beyond a certain value, the suspension system will automatically level.

For safety purpose, height adjustment and easy loading are only available after the doors and front compartment hood are closed. The suspension system automatically sets the corresponding height and adjustable range according to the driving mode and speed, and the user may not be able to manually switch the height.

When the vehicle is running on an uneven road surface, height adjustment may be disabled.

Frequently switching the suspension height in a short period of time may cause the air suspension system to overheat, resulting in failure to switch the suspension height or delayed operation. In such case, do not switch the height until the air suspension system cools down.

When the vehicle is parked for a long time, the suspension height will decrease to some extent, which is normal. Please adjust the suspension to the normal height and above, and ensure that there are no low obstacles around the vehicle. After the vehicle is started, the system will automatically level the suspension.

When the vehicle is transported by road, railway, waterway and other means, the rolling surface of the wheel must be tied and fixed. Otherwise, the pressure change of the air suspension during transportation may cause the vehicle to move, resulting in serious accidents or property loss.

Manual switching of suspension height

Set in the center control screen: Click Settings -> Vehicle -> Suspension, and enter the air suspension setting interface. Click Suspension Height for manually switching the height. During the adjustment of the air suspension, the center control screen displays the current adjustment state.

For vehicles with all-terrain system, press the air suspension system switch (1) on the auxiliary fascia console, and the air suspension lightweight interface appears on the center control screen. The height can be switched manually by flipping the

Starting and Driving

toggle switch (2) up and down, or directly clicking the Height in the lightweight interface.

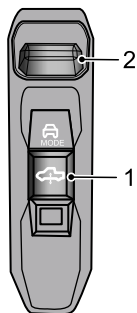

Tandem switching of suspension height

For vehicles with all-terrain system, the suspension will be switched in tandem when switching all-terrain mode.

All-terrain mode	Suspension height
Normal	Normal
Sport	Low
Economic	Low
Snow	Normal
Off-road	High
Towing	Minimum

Note: When the all-terrain mode is custom, the suspension system switches in tandem according to the user-defined height. The suspension system sets the height adjustment range according to different all-terrain modes, and the user will not be able to select all heights.

For vehicles with non-all-terrain system, the suspension will be switched in tandem when switching the driving mode.

Driving mode	Suspension height
Normal	Normal
Sport	Low
Economic	Low

Note: The suspension system sets the height adjustment range according to different driving modes, and the user will not be able to select all heights.

Easy loading

Easy loading mode is used to reduce the height of the rear axle, and enable loading/unloading. Close the door and the front compartment hood, short press the tailgate switch on the upper left side of the tailgate to unlock the tailgate, and short press the switch again to lower the rear axle to the lowest position.

The easy loading can be exited by either of the following methods, and the rear axle will rise to its original height (consistent with the front axle height).

- Press the tailgate switch on the upper left side of the tailgate.

Starting and Driving

- Close the tailgate.
- The speed is higher than 5km/h.

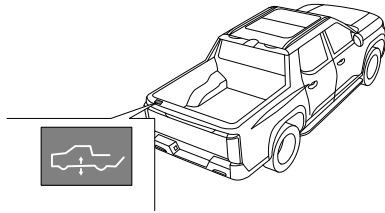

Note: When the rear axle is falling or rising, press the tailgate switch on the upper left side of the tailgate, and the suspension adjustment will be paused; When you continue to press the switch, the suspension adjustment will resume.

Before using the easy loading mode, please pay attention to the cargo placement and obstacles around the vehicle.

When the vehicle is not started, the use of easy loading mode may cause battery feeding. When the battery level is too low, the rear axle may not rise. Please start the vehicle before enabling easy loading.

Vehicle scale

Set in the center control screen: Click Settings -> Vehicle -> Suspension->Vehicle Scale, and enter the vehicle scale

interface. Click Start, and the interface will display weighing information.

Note: The vehicle scale estimates the net load of the vehicle (both cargo and passengers) and is only available when the vehicle is stationary, at normal height, and the brake pedal is released.

The accuracy of the vehicle scale will be affected by the vehicle condition and environment, thus it is necessary to ensure that the wheels face forward, the road is flat and the tire pressure is in the recommended range. The measurement accuracy can be improved if the vehicle is running at a normal height and then stops smoothly.

This function is for your reference only, not for overload determination or cargo trading.

Welcome mode

After the vehicle is parked, the body height will be automatically reduced for easy get on and off. Before parking, please pay attention to low obstacles around the vehicle to avoid damage to the chassis. This mode is available only at normal height, and the height will automatically rise after driving.

Camp mode

Lock the current height to avoid accidental activation of height adjustment while camping. This mode will be disabled automatically after driving.

Starting and Driving

Maintenance mode

The height adjustment function is disabled for you to lift the vehicle with a lift or jack. This mode will be disabled automatically after driving.

Note: *When lifting the vehicle, or repairing the air suspension system, the maintenance mode must be enabled, otherwise the vehicle will be damaged. The maintenance mode is automatically disabled after the vehicle is running. If it is necessary to lift the vehicle or repair the suspension after parking, the maintenance mode must be enabled again.*

Towing mode

Lock the minimum height to ensure the safety of the trailer. This function is automatically triggered when the trailer hook connector is connected or the driving mode is switched to towing mode. The user will not be able to switch to other heights.

Note: *When the trailer hook connector is connected, wait up to 5 minutes before the suspension is adjusted to its lowest height. When the drive mode is out of tow mode and the trailer hook connector is removed, wait up to 5 minutes before the suspension is out of tow mode, during which time you will not be able to switch to other heights.*

ATS (All Terrain System)

Note: *It is applicable to models with the ATS (All Terrain System). The following content contains all the configuration descriptions of this feature, therefore, some of the configuration contents described may not be equipped on your vehicle or only available in some markets, please refer to the actual configuration of the vehicle you purchased.*

The ATS (All Terrain System) automatically optimizes the power and chassis control systems to adapt to the terrain according to the terrain mode selected by the driver, effectively improving the vehicle's passability, stability and off-road capability.



Incorrect use of the terrain mode will cause the vehicle to respond incorrectly to the road conditions, thus shortening the service life of the suspension and drive systems.

The driver should judge the terrain and activate the corresponding All Terrain mode in advance before entering the complex terrain to avoid losing control of the vehicle.













When the "all-terrain system MIL (red)" on the instrument cluster illuminates, please drive immediately to Our Service Dealer for vehicle inspection.



Starting and Driving

ATS mode switch

The ATS has 7 modes and the current vehicle's ATS mode is displayed in the instrument cluster.

- ECO mode:  The "ECO mode indicator (black/white)"  on the instrument cluster illuminates. ECO mode is energy efficient and environmentally friendly, which provides the longest driving range.
- Normal mode:  The "Normal mode indicator (black/white)"  on the instrument cluster illuminates. Normal mode is appropriate for daily driving, which provides the most comfortable driving experience.
- Sport mode:  The "Sport mode indicator (black/white)"  on the instrument cluster illuminates. In Sport mode, the vehicle has strong power characteristics and acceleration response, providing a high-performance driving experience.
- Snow mode:  The "Snow mode indicator (black/white)"  on the instrument cluster illuminates. Snow mode is suitable for low adhesion coefficient road surfaces such as snow, grass or rainy or snowy days, providing the best driving experience.
- Off-road mode:  The "Off-road mode indicator (black/white)"  on the instrument cluster illuminates.

Off-road mode is suitable for rough unpaved roads such as rocky roads, shell craters, intersecting axles, gravel roads, etc., providing the best driving experience.

- Tow mode: The "Tow mode indicator (black/white)"  on the instrument cluster illuminates. Tow mode is suitable for towing the trailer, yacht, RV, bike rack or other outdoor equipment to provide the best driving experience.
- Custom mode: The "Custom mode indicator (black/white)"  on the instrument cluster illuminates. Custom mode can provide personalized driving experience after the drivers set the driving mode according to their own preferences.

By moving the toggle switch (2) up and down, you can switch among ECO, Normal, Sport, Snow, Off-road, Tow and Custom modes.

You can also switch among ECO, Normal, Sport, Snow, Off-road, Tow and Custom modes by clicking on the central control screen after you move the toggle switch (2) up and down or press the ATS switch (1) on the auxiliary fascia console, and the All Terrain Lightweight interface pops up on the central control screen.

Starting and Driving

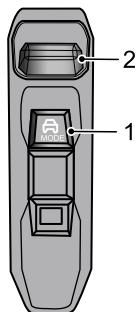

Custom mode

You can enter the Custom mode and customize the vehicle's power mode, ESC (Electronic Stability Control) mode, power steering mode, suspension height, and energy recovery level according to your driving needs in the All Terrain interface.

Entering All Terrain interface

You can click "More settings" in the All Terrain Lightweight pop-up window displayed in the central control screen to enter the All Terrain interface; you can also set in the central control screen: click Settings-> Driving Preferences-> All Terrain mode to enter the All Terrain interface.

You can change the names of Custom modes 1, 2 and 3 according to your driving needs. And define the power mode,

ESC (Electronic Stability Control) mode, power steering mode, suspension height and energy recovery level.

- Power mode: Normal, Sport and ECO can be selected.
 - Normal: Combines vehicle dynamics and economy and be suitable for all road surfaces.
 - Sport: Increases vehicle dynamics, bringing a higher level of responsiveness and driving experience. Suitable for flat road surfaces with fewer vehicles and extensive driving.
 - ECO: Improves vehicle power economy and be suitable for flat, hard surfaces such as city streets and paved roads.
- Electric power steering mode: the steering feel can be selected from standard, sporty, and comfortable.
 - Standard: The steering wheel has moderate steering force and is suitable for general driving habits.
 - Sport: The steering assistance is reduced, and the steering wheel turns more steadily.
 - Comfortable: With increased steering assistance, the steering wheel turns more easily.
- ESC (Electronic Stability Control) mode: Normal, Reduced and OFF can be selected.
 - Normal: ESC (Electronic Stability Control) is on.
 - Reduced: TCS (Traction Control System) and VDC (Vehicle Dynamics Control) are off.
 - OFF: ESC (Electronic Stability Control) is off.

Starting and Driving

- Air Suspension System Height: Highest, High, Standard, Low and Lowest modes can be selected. See "Air suspension system" in this section for more instructions.
- Energy Recovery Level: Low, Standard, High modes can be selected.

Note: When the All Terrain mode is switched to Snow mode and Off-road mode, some auxiliary functions of the vehicle will be automatically exit or turn off, such as ACC (Adaptive Cruise Control), Auto Park, ESC (Electronic Stability Control), etc.

Four-wheel drive system

Note: It is applicable to models with the four-wheel drive (4WD) system. The following content contains all the configuration descriptions of this feature, therefore, some of the configuration contents described may not be equipped on your vehicle or only available in some markets, please refer to the actual configuration of the vehicle you purchased.

Four-wheel drive (4WD) system is defined as a real-time 4WD system which realizes 4WD functionality via the front and rear motors. The front axle motor engages through a one-way clutch control torque in Drive gear, but it is not involved in Reverse gear.



When the "power system fault warning light



(yellow/red)" on the instrument cluster illuminates, please drive immediately to Our Service Dealer for vehicle inspection.

4WD mode switch

The switching of 4WD modes is dependent on the All Terrain mode, and the 4WD system will automatically call up the relevant 4WD mode when switching to a different All Terrain mode.

- When the All Terrain mode is switched to ECO mode, the 4WD strategy prioritizes economy and enters 4WD when there is a demand for high torque power.

Starting and Driving

- When the All Terrain mode is switched to Sport mode, the 4WD strategy prioritizes dynamics and enters 4WD when a certain vehicle speed is reached.
- When the All Terrain mode is switched to Normal Mode, the 4WD strategy adopts real-time 4WD, balancing economy and dynamics.
- When the All Terrain mode is switched to Off-road, Snow or Tow mode, the 4WD strategy adopts full-time 4WD.

Crawl control in off-road

Note: *It applies to vehicles configured with the crawl control in off-road system.*



The crawl control in off-road is only an auxiliary function and cannot replace the driver's judgment on road and traffic conditions, let alone driving. The driver is responsible for the safety of the vehicle under all circumstances, and must concentrate on driving carefully at all times.

Improper use of off-road cruise control may result in a crash.

If crawl control in off-road is used continuously for an extended period of time, or the brake pedal is depressed several times in a row during normal driving, it may lead to overheating of part of the system, at this time, the instrument cluster will display the relevant alarm message and the "CCO (Crawl Control in Off-road) indicator light" will go out or the yellow indicator light will light up, in the case of the above situation, please park the vehicle immediately in a safe place and allow the vehicle to power down to cool the relevant system.

Your vehicle may be equipped with the crawl control in off-road system. With the crawl control in off-road, you only need to concentrate on controlling the steering wheel of the vehicle

Starting and Driving

without depressing the accelerator and brake pedals to keep the vehicle moving at the set speed. It can be used when the vehicle enters the Off-Road mode, is put into driving gear and drives at low speeds in off-road conditions, bumpy road conditions or when getting the vehicle out of a trap, so as to avoid changes in the accelerator pedal amplitude caused by bumps in the road.

The crawl control in off-road switch is located on the center console screen, click Settings -> Driving Preferences -> Crawl Control in Off-road to turn the Crawl Control in Off-road System on and off. The "CCO (Crawl Control in Off-road) indicator



light" in the instrument cluster illuminates or goes out accordingly. The following basic conditions must be met in order to switch on the crawl control in off-road system:

- The current vehicle speed is below 20km/h.
- The driver door is fully closed.
- The driver is wearing the seat belt correctly.
- It already enters the Off-road mode.
- The vehicle is powered on, and put into driving gear.
- The EPB (Electrical Parking Brake) is released.

The crawl control in off-road has a total of 9 gears, the control switch is located on the steering wheel, the crawl control in off-road target gear can be set by the following methods and displayed on the instrument cluster.

RES+: Upshift switch.

SET-: Downshift switch.

Depress the accelerator pedal or brake pedal, adjust the vehicle to the desired speed and release the pedal.

Note: When the cruise speed exceeds 20 km/h, the crawl control in off-road goes into standby; when the cruise speed exceeds 35 km/h, the crawl control in off-road is automatically turned off.

⚠ Under certain conditions, the crawl control in off-road may not be able to maintain a constant low speed, which could lead to an accident, e.g., steep slopes, rugged surfaces, snowy/icy or slippery road surfaces.

Some typical terrains and the corresponding gear settings are listed below for your reference:

CCO target gear setting	Road conditions
1st gear - 2nd gear	Rocky road surface, bumpy road surface (downhill), cross axle road surface
3rd gear - 4th gear	Bumpy road surface (uphill), gravel road surface (downhill)
5th gear - 6th gear	Snowfield, mud ground, gravel road surface (flat or uphill)
7th gear - 9th gear	Sandy ground, muddy road surface, grassland

Starting and Driving

Parking assist system

Note: *The type of parking assist system equipped on your vehicle is subject to the actual vehicle configuration purchased.*

Camera provides visual aids for the parking assist system. See "Camera" in Driver assistance system for details. Ultrasonic radar provides object detection for the parking assist system. See "Radar" in Driver assistance system for details.

Front and rear sensors



The parking assist system is not always reliable and is only playing the role of guidance! The sensors might not detect some types of obstacles, including slim objects (such as wire nets and ropes), small objects close to the ground, conic objects, and some objects with non-reflective surfaces.

The sensors shall be free of dirt, ice, and snow. The sediment on surfaces of sensors will impair the normal functioning of the sensors. Therefore, avoid directly flushing the sensors from a short distance by a high pressure water gun while washing your vehicle.

The radar sensor located in the front bumper will scan the front area of the vehicle, and the radar sensor located in the rear bumper will scan the rear area of the vehicle, in order to judge

the presence of obstacles. Upon detection of any obstacle, the parking sensors will calculate its spacing with the vehicle and send the information to the driver by alerting tones. It's really important that this system is only a parking assist system and can't function as the replacement for your observation and personal judgment.

Working status of parking assist system with front and rear sensors

Rear parking assist system

After selecting reverse gear R, if the parking assist system has no faults, the system will automatically start working. When selecting other gears, the rear parking assist system will stop working.

Front parking assist system

When selecting the reverse gear or the drive gear or N gear and parking brake released, the vehicle speed rises from 0km/h to 15km/h, the front parking assist system works; when the vehicle speed drops from 15km/h to 12km/h, the front parking assist system is in standby mode; when the vehicle speed drops to 12km/h or below, the front parking assist system works.

Note: *If the system keeps ringing for a long time after the reverse gear or the drive gear is selected, it indicates that the system has a malfunction. Contact Our Service Dealer for service as soon as possible.*

Starting and Driving

Parking assist system switch on the central control screen

Press the parking assist system switch on the central control screen to enable or disable the front/rear radar parking assist system. Parking assist system is defaulted to be enabled after the vehicle is powered on and starts to output working status. In the same ignition cycle, when the reverse gear R is engaged, the disabled parking assist system is forced to be enabled; in the case that the reverse gear R is engaged, if the parking assist system is switched off, the function of this system will be disabled; and the disabled function will be enabled automatically in the next ignition cycle.

Parking process

When the two middle radars in the rear of the vehicle are about 150cm away from the barrier, or when the radars on both sides are about 60cm away from the barrier, the parking assist system starts to make alarm sounds and display the alarm distance. And the alarm sound become harsher when the vehicle is approaching the barrier.

When the radars on both sides of the front of vehicle are about 60cm away from the barrier, the parking assist system will start making alarm sounds. And the alarm sound become harsher when the vehicle is approaching the barrier.

Note: For vehicles equipped with four radars on the front bumper, when the two middle radars in the front of the

vehicle are about 120cm away from the barrier, the parking assist system will start making alarm sounds.

When the distance of the vehicle from the barrier is less than 30cm, the parking assist system will sound a long alarm. At this moment, it is impossible to effectively identify the barrier if you continue to reverse the vehicle.

Note: When the vehicle is more than 30cm away from an obstacle, the front radar implement 6-second mute strategy with the drive gear D or N engaged. If the distance maintains for 6s without any change, the alarm sound will stop, otherwise it will resume.

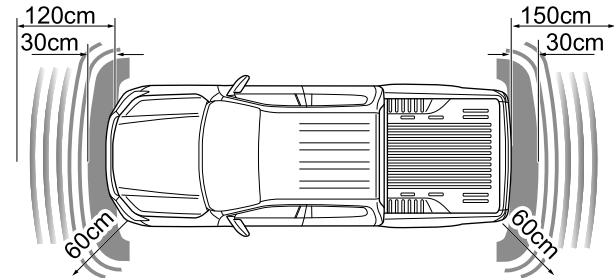

Rear view camera

! The parking camera assist system is not always reliable and is only playing the role of guidance! Due to limited visual field, the parking camera can't detect any obstacle beyond its visual field.

Starting and Driving

Working status of parking camera assist system:

After selecting reverse gear, the image of center console screen will be switched to the working status of parking camera, and the display will show the scene image behind the vehicle for the driver's reference during reversing.

When selecting other gears, the parking camera assist system stops working and the display returns to the original state.

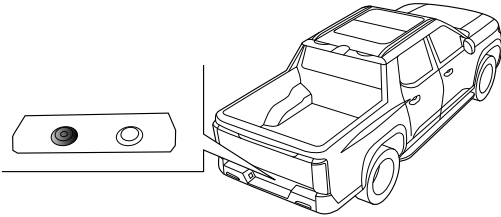

Note: When the vehicle enters the reversing state, the central control screen displays that the reverse assist line is based on the ground plane as a reference. If the reverse image system cannot operate normally, the central control screen will display a fault prompt for the reverse image system. Please contact Our Service Dealer for repair as soon as possible.

Note: If you adjust the screen brightness on the central control screen, the brightness will synchronously affect the reverse image interface.

360°/540° around view system

⚠️ 360°/540° around view system is not always reliable. It only plays the role of assistance! Due to the limited filed of view, the cameras cannot detect an obstacle in the blind spot or beyond its field of view. Please carefully check the surroundings of the vehicle even when the system is in operation.

360°/540° around view system consists of four cameras, respectively installed in the front, rear, left and right of vehicle, and one controller.

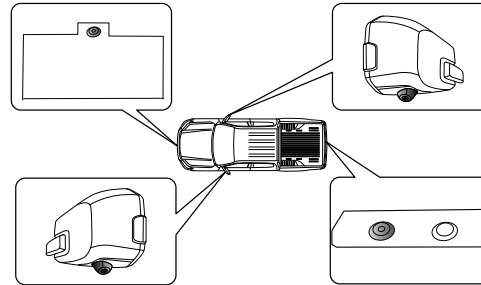

360°/540° around view system provides various auxiliary functions including:

- 2D view
- 3D view

- Function settings

Note: *The type of 360°/540° around view system equipped on your vehicle is subject to the actual vehicle configuration purchased. Some models do not support 2D view, 3D view, and function settings.*

Note: *If you adjust the screen brightness on the center console screen, the brightness will simultaneously affect the image interface of 360°/540° around view system.*

2D/3D around view system

Function activation

- The around view system is triggered after the reverse gear R is selected.
- You can wake up the around view system via the "360" icon on the main interface of the center console screen.

After the function is activated, the 2D/3D and front/rear/left/right views can be switched in the operation area. Meanwhile, you can switch to the front/rear wheel view and front wide-angle view in the 2D view. The wheel view can provide a view of both sides of front wheels, such as observing road curbs and low obstacles on both sides of the wheels to avoid scratches.

Function deactivation

- Click the "X" on the upper left of around view interface to close it.
- The system automatically exits when the vehicle exceeds a certain speed.

Function settings

The user can choose to turn on/off "360° triggered by vehicle start-off", "360° triggered by steering wheel angle at low speed", "360° triggered by turning", "360° triggered by narrow road", "Transparent chassis", "Guide line display" and other sub-functions by click "Settings" on the around view interface.

- 360° triggered by vehicle start-off

After the function is enabled, the around view system will be automatically turned on when the vehicle starts off for the first time in an ignition cycle.

- 360° triggered by steering wheel angle at low speed

After the function is enabled, the around view system will be automatically turned on when the steering wheel angle of the vehicle reaches a certain angle at low speed.

- 360° triggered by turning

After the function is enabled, you can choose Picture-in-picture or Full screen on the center console screen.

If you choose "Picture-in-picture", the instrument or center console displays the view of the corresponding front side blind spot when the vehicle is driven at low speed and the turn signal lamp is turned on; the instrument or center console displays the view of the corresponding rear side blind spot when the vehicle is driven at high speed and the turn signal lamp is turned on. If you choose "Full screen", when the turn signals are turned on at low speeds, the surround view system

Starting and Driving

screen will only be displayed in full screen on the central control screen.

- 360° triggered by narrow road

After the function is enabled, the around view system will be automatically turned on when the forward side parking radar detects an obstacle at a certain distance while the vehicle is driven at low speed.

- Transparent chassis

The transparent chassis function can switch the body in 2D and 3D images to a transparent state and display the view under the body to help the user know the potential safety hazards on the road, such as roads with pits, low obstacles, etc.

- Guide line display

After the function is enabled, the guide lines are displayed on the around view system or single view interface.

Note: Depending on the vehicle configuration, the above functions and their specific description may vary, which shall be subject to the actual configuration of the vehicle you purchased.

Caution

When a camera failure icon  appears on the 360° interface or if you find blank screen in a single camera, you should contact Our Service Dealer for repair as soon as possible.

Driver assistance system

Note: The type of driver assistance system equipped on your vehicle is subject to the actual vehicle configuration purchased.

Camera

Front-view camera is installed inside the front windshield at the interior rear-view mirror. Front-view camera provides target acquisition for the driver assistance system.

Caution

The camera sensor hardware must be repaired or replaced in a timely manner if damaged. It is recommended that you drive the vehicle to Our Service Dealer for repair, and do not make replacement yourself.

It is not allowed to install license plate frame and other items on the front and rear license plate boards to prevent interference with camera or radar; regular maintenance and service shall be provided to the license plate to avoid impact on the radar performance due to deformation.

The camera cannot work properly in all traffic environments, weather and driving conditions. In case of a complex environment or poor weather, please drive cautiously and carefully.

Camera maintenance

To ensure the normal operation of a camera, keep the camera free of foreign objects such as dust, snow, ice and water.

After a camera is replaced, the assembly structures must be the company's genuine parts. After the parts are replaced, the camera must be re-calibrated at Our Service Dealer to ensure that all camera-based vehicle systems are functioning properly.

Use restrictions

If a camera can not work properly, the functions that rely on the camera to provide detection information are limited or abnormal.

The detection range and capability of a camera are limited, and the targets and capabilities beyond the detection range of the camera cannot be detected.

The performance and capability of a camera will be inhibited in the following environments:

- The camera's field of view is blocked, and the surface is attached by foreign objects, such as dust, snow, ice, water and frost.
- The weather conditions are poor, such as poor light or visibility.
- The camera is overexposed due to direct sunlight.
- The light changes dramatically (e.g. entering or exiting a tunnel).
- The camera wobbles due to bumps in the road or other reasons.

Radar

The front millimeter wave radar is installed on the front bumper, and the rear corner millimeter wave radar is installed inside the side of the rear bumper. The millimeter wave radar provides target detection for the driving assistance system. The ultrasonic radar is installed on the front and rear bumpers, providing target detection for the parking assist system.

Caution

To avoid impact on the radar detection performance, it is strictly prohibited to perform operations such as painting and modification to the body and front and rear bumpers without authorization.

The radar sensor hardware must be repaired or replaced in a timely manner if damaged. It is recommended that you drive the vehicle to Our Service Dealer for repair, and do not make replacement yourself.

It is not allowed to install license plate frame and other items on the front and rear license plate boards to prevent interference with camera or radar; regular maintenance and service shall be provided to the license plate to avoid impact on the radar performance due to deformation.

Radar sensors cannot work properly in all traffic environments, weather and driving conditions. In case of a complex environment or poor weather, please drive cautiously and carefully.

Starting and Driving

Radars maintenance

To ensure the normal operation of a radar, keep the radar free of foreign objects such as dust, snow, ice and water.

When there is a foreign object in the front of the radar, clean it with a soft cloth. Do not use a high-pressure water gun to clean it, or damage the front surface of radar.

After a radar is replaced, the assembly structures must be the company's genuine parts. After the parts are replaced, the radar must be re-calibrated at Our Service Dealer to ensure that all radar-based vehicle systems are functioning properly.

Use restrictions

If a radar can not work properly, the functions that rely on the radar to provide detection information are limited or abnormal.

The detection range of the radar is limited, and the targets beyond the detection range of the radar cannot be detected.

The performance of a radar will be inhibited in the following environments:

- The surface of the radar is attached by foreign objects, such as dust, snow, ice, and water.
- The objects detected by the radar have wave-absorbing interfering substances, such as cotton objects.
- The weather is poor, such as heavy rain, snow, fog, etc.
- The radar wobbles due to bumps in the road or other reasons.

FCW and AEB (Forward Collision Avoidance Assist)

The forward collision avoidance assist includes FCW (Front Collision Warning) and AEB (Automatic Emergency Braking). FCW uses visual and audible signals to warn the driver of pedestrians, bicycles or vehicles in front of the vehicle. If the driver fails to act within a reasonable period of time, the system will trigger the AEB.

Collision avoidance assist function may enable rapid, instantaneous braking to respond to different collision risks, which may make the driver feel uncomfortable. In this case, the driver should apply brake actively.

If the collision risk increases further, the system will brake sharply and stop the vehicle under normal conditions. For most drivers, it is not a normal driving style and they may feel uncomfortable. After the collision avoidance assist function successfully avoids a collision with the vehicle ahead, the vehicle will remain stationary for a short time and the driver should take action as soon as possible.

Generally, the driver or passenger only notices the collision avoidance assist function when the vehicle is about to have a collision. The collision avoidance assist function is activated when the driver should start braking early, but it can not help the driver in all situations.

Starting and Driving

Function enable/disable

Function enable method

When the vehicle is started, the collision avoidance assist function is enabled by default.

If you disable the function and then enable it again, you may set it in the central control screen: Settings -> Advanced driver assistance -> Enable collision avoidance assist.

When the function is enabled, the "FCW (Front Collision Warning)/AEB (Automatic Emergency Braking) warning light

(yellow)"  on the instrument cluster goes out.

Function disable method

Set it in the central control screen: Settings -> Advanced driver assistance -> Disable collision avoidance assist.



When the function is disabled, the FCW and AEB functions will be disabled together, and the "FCW (Front Collision Warning)/AEB (Automatic Emergency Braking) warning light

(yellow)"  on the instrument cluster stays on.

Sensitivity adjustment

In the central control screen, click "..." or ">" on the right side of the Collision Avoidance Assist, the Low, Standard, and High options will be displayed. You can choose the right sensitivity for your needs.

Message prompt

- Visual alarm
 - Indicator prompt messages: In case of FCW, the "FCW (Front Collision Warning)/AEB (Automatic Emergency Braking) warning light (yellow)"  flashes; when AEB is activated, the "FCW (Front Collision Warning)/AEB (Automatic Emergency Braking) warning light (red)"  flashes.
 - Text reminder messages: risk of collision/AEB enabled.
- Audible alarm: entertainment system speaker alarm.

Caution

Collision avoidance assist is an assistance function that does not work in all driving situations, traffic, weather and road conditions, and is not a substitute of the driver in making right judgment. The system performance may be degraded due to other factors, thus the driver shall carefully observe the road conditions, drive with caution, and shall not fully rely on the system. Before using the collision avoidance assist function, the driver should refer to this section for the restrictions.

The collision avoidance assist function is not designed to fully prevent collisions, but to minimize the speed, reducing the loss caused by collision. The driver shall drive with caution and never fully rely on the system.

Starting and Driving

Caution

When the system sends visual and audible alarm, it is the driver's responsibility to immediately take further measures to avoid collision risks and never rely solely on the system.

The detection range of the front view camera and the front millimeter-wave radar enabled by the collision avoidance assist function is limited, so do not rely solely on the system to prevent collisions.

Due to inherent restrictions, the system may send a warning or brake when there is no collision risk. The driver should pay attention to the traffic environment ahead, and take corresponding measures in time.

The working range of the collision avoidance assist system is 8km/h to 140km/h.

When the collision avoidance assist function is enabled, if the "FCW (Front Collision Warning) and AEB (Automatic



Emergency Braking) warning light (yellow)" stays on, please contact Our Service Dealer for service.

Use restrictions

- When the speed is less than 8km/h, the system does not sound an alarm, and may be triggered occasionally at a lower speed on congested roads, which may bring poor driving feelings.

- The driver must ensure that the seat belt is fastened, otherwise the AEB will not work.
- Ensure that the electronic stability system and the collision avoidance assist function are enabled, otherwise the collision avoidance assist function will not work.
- Some targets may affect and weaken the detection of sensor, such as road fences, tunnel entrances, rain or ice and snow, thus affecting relevant AEB functions.
- The prerequisite for collision avoidance assist system to respond to the relevant target is that the target must be in the field of view of the sensor and be recognized. For targets cutting into, targets detected only after the vehicle changes lanes, and targets on the road with sharp turns, the collision avoidance assist performance will be greatly restricted.
- Due to traffic conditions or external influences, if the cameras and radars cannot correctly detect pedestrians, cyclists, vehicles and other objects, the warning and braking interventions may be delayed or not activated at all.
- The detection capability of cameras may be affected by bad weather, such as strong wind, heavy rain, fog, etc., which will reduce the system performance or increase the false trigger rate.
- See "Camera" for camera restrictions.
- See "Radar" for radar restrictions.

LDW (Lane Departure Warning)

LDW (Lane Departure Warning) function provides assistance to drivers on highways, expressways and other similar main roads. When the driver unconsciously deviates from the lane, it warns and prompts the driver to return to the current lane, avoiding the possible traffic accident.

When the speed is greater than or equal to 60km/h and the road markings are clearly visible, the LDW function is activated.

When the driver is driving at a low speed or in an active driving state (judged by operating direction-indicator lamp/changing lanes sharply, etc.), the system will not issue an alarm message.

Function enable/disable

Function enable method

When the vehicle is started, the LDW function is enabled by default.

To reactivate the function after you deactivate it, set on the center console screen: Settings -> Advanced Driver Assistance-> Activate Lane Keeping Assist.

Function disable method

Set it in the central control screen: Settings -> Advanced driver assistance -> Disable lane assist.

When the function is deactivated, the "LDW (Lane Departure Warning)/LKA (Lane Keeping Assist)/ELK (Emergency Lane

Keeping) warning light (yellow)"  on the instrument cluster remains on.

Alarm sound settings

Set it in the central control screen: Settings -> Advanced driver assistance -> Enable lane assist-> More -> Turn on or off the sound.

Sensitivity adjustment

In the central control screen, click "... " or ">" on the right side of the lane assist, the Low, Standard, and High options will be displayed. You can choose the right sensitivity for your needs.

Message prompt

When the driver unconsciously deviates from the lane, the system will remind the driver through the alarm icon on the instrument cluster, accompanied by the sound of the buzzer, and the lane line on the corresponding side of the instrument cluster will be displayed in red. It indicates that the vehicle is at risk of deviating from current lane, in which case, the driver should correct the vehicle to return to current lane in time.

Starting and Driving

Caution

LDW is only a driver assistance function to assist alarm.

The driver shall not rely entirely on the LDW function to remind himself whether to drive out of the lane, and the driver shall bear the responsibility for safe driving.

LDW cannot function in all driving conditions or traffic, weather and road conditions.

When the lane keeping assist system fails, i.e. after the lane keeping assist function is activated, the "LDW (Lane Departure Warning)/LKA (Lane Keeping Assist)/ELK (Emergency Lane Keeping) warning light (yellow)" remains on, please drive to Our Service Dealer for service.

Use restrictions

LDW cannot clearly detect the lane line at any time. You may receive useless or invalid warning in the following circumstances.

- Road construction areas, sharp turns or narrow roads.
- Dark (poor lighting) or weather conditions (due to heavy rain, snow, fog and wind).
- The camera has poor recognition capability due to direct sunlight or oncoming strong light.
- The vehicle ahead is large or close, blocking the camera's field of view.
- The windscreen in the camera's field of view is blocked (by water mist, dust or sticker, etc.).

- The width and quality of the lane lines do not meet the requirements, such as the lane line is worn and covered, the old and new lane lines exist together, or the lane line is changed due to the construction section.
- The projection of trees, large objects or landscape features, etc. on the driveway creates large shadows.
- LDW may miss warnings or issue false warnings in the following circumstances:
 - See "Camera" for camera restrictions.
 - Weather conditions (heavy rain, snow, fog, extreme heat or cold temperatures) interfere with camera operation.

The above warnings and restrictions do not include all conditions that may interfere with LDW. There are many factors that can cause LDW to fail. In order to avoid deviating from the lane, the driver needs to remain alert, and always pay attention to the road conditions, so as to take corrective measures as soon as possible.

LKA (Lane Keeping Assist)

After the LKA (Lane Keeping Assist) function is activated, based on the road boundary information obtained by the camera, the system will determine the position relationship of the vehicle relative to the lane line. Based on the vehicle state and driver input, if the driver unintentionally deviates from the lane, the system will warn the driver or correct the vehicle to the lane by intervening the steering. It is a safety function to only correct the vehicle when the vehicle is about to deviate from the lane, but not a comfort function to keep the vehicle in the center of the lane. The driver should always hold the steering wheel.

When the speed is 60 to 130km/h and the road markings are clearly visible, the lane keeping function is activated.

When the driver is driving at a low speed or in an active driving state (judged by changing lanes sharply, etc.), the system will not issue an alarm or automatically intervene the steering.

Function enable/disable

The LKA (Lane Keeping Assist) shares the switch of LDW (Lane Departure Warning), and its specific operations are shown in "LDW (Lane Departure Warning)" in this section.

Message prompt

When the driver unconsciously deviates from the lane, the system will remind the driver through the alarm icon on the instrument cluster and the sound of the buzzer, and may intervene the steering to bring the vehicle back to the lane.

Caution

LKA is only a driver assistance function. The driver shall not rely entirely on LKA function to prevent the vehicle from deviating from the current lane, and the driver shall bear the responsibility for safe driving.

The driver shall obey traffic rules and hold the steering wheel with both hands. The system will not provide LKA if the driver does not hold the steering wheel.

The lane keeping assist will not always help the driver to correct the vehicle with a tendency of departure, and the driver must take over the vehicle after correction to ensure that the vehicle is stable. The lane keeping assist cannot work under all driving or traffic, weather and road conditions. When the lane keeping assist system fails, i.e. after the lane keeping assist function is activated, the "LDW (Lane Departure Warning)/LKA (Lane Keeping Assist)/ELK (Emergency Lane Keeping) warning light (yellow)" remains on, please drive to Our Service Dealer for service.

If your replacement of vehicle suspension kit is not approved by us, the LKA system may not work properly.

Use restrictions

LKA cannot clearly detect the lane line at any time. You may receive invalid warning or false interference in the following circumstances.

- Road construction areas, sharp turns or narrow roads.

Starting and Driving

- Dark (poor lighting) or weather conditions (due to heavy rain, snow, fog and wind).
- The camera has poor recognition capability due to direct sunlight or oncoming strong light.
- The vehicle ahead is large or close, blocking the camera's field of view.
- The windscreen in the camera's field of view is blocked (by water mist, dust or sticker, etc.).
- The width and quality of the lane lines do not meet the requirements, such as the lane line is worn and covered, the old and new lane lines exist together, or the lane line is changed due to the construction section.
- The projection of trees, large objects or landscape features, etc. on the driveway creates large shadows.
- LKA may miss warnings or issue false warnings in the following circumstances:
 - See "Camera" for camera restrictions.
 - Weather conditions (heavy rain, snow, fog, extreme heat or cold temperatures) interfere with camera operation.

The above warnings and restrictions do not include all conditions that may interfere with LKA. There are many factors that can cause LKA to fail. In order to avoid deviating from the lane, the driver needs to remain alert, and always pay attention to the road conditions, so as to take corrective measures as soon as possible.

ELK (Emergent Lane Keeping)

After the ELK (Emergent Lane Keeping) function is activated, based on the road environment information obtained by the camera and angle millimeter-wave radar, the system will determine the position relationship of the vehicle relative to adjacent vehicles or curbs. Based on the vehicle state and driver input, if the driver unintentionally deviates from the lane, leading to collision risk with adjacent vehicles or curbs, the system will warn the driver or keep the vehicle away from collision risk by intervening the steering. ELK is a safety function, but not a comfort function.

When the speed is 60 to 130km/h and the road markings are clearly visible, the lane keeping function is activated.

When the driver is driving at a low speed or in an active driving state (judged by changing lanes sharply, etc.), the system will not issue an alarm or automatically intervene the steering.

Function enable/disable

The ELK (Emergency Lane Keeping) shares the switch of LDW(Lane Departure Warning), and its specific operations are shown in "LDW (Lane Departure Warning)" in this section.

Message prompt

When the driver unconsciously deviates from the lane, leading to collision risk with adjacent vehicles or curbs, the system will remind the driver through the alarm icon on the instrument cluster and the sound of the buzzer, and may intervene the

Starting and Driving

steering to keep the vehicle away from collision risk such as adjacent vehicles or curbs.

Caution

ELK is only a driver assistance function. The driver shall not rely entirely on ELK function to prevent the vehicle from collisions with the adjacent vehicles or curbs, and the driver shall bear the responsibility for safe driving.

The driver shall obey traffic rules and hold the steering wheel with both hands. The system will not provide ELK if the driver does not hold the steering wheel.

ELK does not always help the driver correct the vehicle tending to have a collision with adjacent vehicle or curb and keep it away. After the correction, the driver must take over the vehicle to ensure stable driving.

ELK cannot function in all driving conditions or traffic, weather and road conditions.

When the emergency lane keeping assist system fails, i.e. after the lane keeping assist function is activated, the "LDW (Lane Departure Warning)/LKA (Lane Keeping Assist)/ELK



(Emergency Lane Keeping) warning light (yellow)" remains on, please drive to Our Service Dealer for service.

If your replacement of vehicle suspension kit is not approved by us, the ELK system may not work properly.

Use restrictions

ELK cannot clearly detect the lane line at any time. You may receive invalid warning or false interference in the following circumstances.

- Road construction areas, sharp turns or narrow roads.
- Dark (poor lighting) or weather conditions (due to heavy rain, snow, fog and wind).
- The camera has poor recognition capability due to direct sunlight or oncoming strong light.
- The camera cannot accurately recognize the target that needs to be avoided when the side vehicle is large, has an irregular appearance, or the curb is badly damaged or non-standard.
- The camera's field of view is blocked (by water mist, dust or sticker, etc.).
- The width and quality of the lane lines do not meet the requirements, such as the lane line is worn and covered, the old and new lane lines exist together, or the lane line is changed due to the construction section.
- The projection of trees, large objects or landscape features, etc. on the driveway creates large shadows.
- LKA may miss warnings or issue false warnings in the following circumstances:
 - See "Camera" for camera restrictions.
 - Weather conditions (heavy rain, snow, fog, extreme heat or cold temperatures) interfere with camera operation.

Starting and Driving

The above warnings and restrictions do not include all conditions that may interfere with ELK. There are many factors that can cause ELK to fail. In order to avoid collision risk with adjacent vehicles or curbs, the driver shall remain alert, and always pay attention to the road conditions, so as to take corrective measures as soon as possible.

ACC (Adaptive Cruise Control)

ACC (Adaptive Cruise Control) helps the driver maintain the same speed as that of the vehicle ahead and maintain a pre-selected time gap. For long-distance driving on smooth highways and long, straight trunk roads, ACC system can make your driving experience more relaxed and comfortable. The driver can set the required speed and time gap with the vehicle ahead. When the cameras and front millimeter-wave radar detect that the vehicle ahead has slowed down, the vehicle will also automatically slow down accordingly. The road ahead is clear again, and the vehicle returns to the selected speed.

Adaptive cruise control switch

The adaptive cruise control switch is located on the steering wheel.

: Adaptive cruise control master switch, short press to turn the system on.

When the adaptive cruise control is activated:

: Adaptive cruise control deactivation switch, short press to deactivate the adaptive cruise control without clearing the set cruise speed.

RES+: To increase the saved vehicle speed or re-activate the adaptive cruise control and restore the saved speed.

SET-: Decrease the stored vehicle speed.

Starting and Driving

: To set the following distance, adjust the following distance of the adaptive cruise control, and switch the following distance from Level 1 to Level 3 cyclically for each press.

Activation of adaptive cruise control

After the vehicle is started, when a target is detected ahead, the ACC function can be activated at any speed; if no target ahead is detected, the vehicle needs to run at a speed of more than 15km/h before the ACC function is enabled. When the speed is below 120km/h, the ACC (Adaptive Cruise Control) function can be activated. For ACC (Adaptive Cruise Control), the speed can be set at 15 to 150km/h.

When the "ACC (Adaptive Cruise Control) indicator (grey)"



in the instrument cluster illuminates, it means the ACC function is ready for your use.

In this state, you can press  to activate the ACC (Adaptive Cruise Control) function.

After the ACC (Adaptive Cruise Control) function is activated, the



"ACC (Adaptive Cruise Control) indicator (blue)" in the instrument cluster illuminates.

After the system is activated, the vehicle will cruise according to the set cruise speed when there is no other vehicle ahead; when a target vehicle ahead is detected and its speed is more than the set cruise speed of the vehicle, the system continues to make the vehicle run at the current cruise speed. When the

speed of the vehicle ahead is less than the set cruise speed of the vehicle, the system will actively adjust the speed to maintain the set time gap with the vehicle ahead, enabling the automatic vehicle following function. When the vehicle ahead accelerates, the system will also actively accelerate until the set cruise speed is restored.

Adjustment of cruise speed

When the ACC (Adaptive Cruise Control) is enabled, the cruise speed can be increased or decreased by RES+ and SET-.

Short press RES+/SET-, and the cruise speed changes at a speed of 5km/h.

Long press RES+/SET-, and the cruise speed changes at a speed of 1km/h.

When the ACC (Adaptive Cruise Control) is in an override state, you can move the shift lever downward to the bottom and then release it to change the cruise speed to actual speed.

Memory of cruise speed

ACC has been activated in this ignition cycle, and the cruising speed will be the previous speed when entering next time. The cruising speed is not stored in memory after the vehicle is powered off.

Adjustment of cruise distance

Short press , the following distance will be switched between Level 1 to 3 each time the button is pressed, and the current

Starting and Driving

following distance can be confirmed through the display on the instrument cluster.

Deactivation of adaptive cruise control

To manually deactivate ACC, you can pull the shift lever upward or switch gears and press the brake pedal. When ACC is exited, ACC (Adaptive Cruise Control) indicator will change from blue to grey, or ACC (Adaptive Cruise Control) indicator extinguishes.

Deactivation of adaptive cruise control

If you need to exit the cruise manually, you may do it by pressing the ACC deactivation switch  or pressing the brake pedal. After exiting ACC, ACC indicator will change from blue to gray, or disappears

Restoration of adaptive cruise control

ACC has been activated in this ignition cycle. If you want the cruising speed of the next entry to be the previous speed, press the RES+ button.

If the vehicle cruises at the current speed, the system can be restored by enabling the ACC.

In the following cases, the system will enter the function holding state and will not restore, and the instrument cluster will provide relevant information to prompt the need of cruise restoration:

- The following/stop time exceeds 180s.
- A pedestrian is detected ahead.

Caution

The driver must always be aware of the current traffic conditions and intervene if the ACC system does not maintain a suitable speed or a correct following distance. ACC system is not applicable to all traffic, weather and road conditions.

ACC is not a safety system, obstacle detector or collision warning system, but a comfort system. Therefore, the driver must always control the vehicle and take full responsibility for the vehicle.

ACC can assist the driver, but it is not a substitute of the driver in driving. Even when ACC is active, the driver must also drive cautiously and obey speed limit rules.

When ACC is active, if the driver depresses the accelerator pedal, the vehicle will be taken over by the driver. The following distance control function of ACC system will not be activated.

For stationary objects, such as the tail-end of a traffic flow, toll stations, etc., ACC can respond only in special states, which are highly specific.

In some conditions (the relative speed of the vehicle ahead is too high, the lane change is too fast, or the safety distance is too small, etc.), the time is not sufficient enough for the system to reduce the relative speed. In this case, the driver must react appropriately. The system cannot issue an audible or image warning in every case.

Starting and Driving

Caution

When the vehicle is entering and exiting a curve, target selection may be delayed or interfered with. In these cases, the vehicle with ACC may not brake as intended or brake too late. On roads with sharp turns, such as snake roads, the vehicle ahead may be invisible within a few seconds due to limitation of the sensor's field of view, which may cause the vehicle with ACC to accelerate.

If the distance between the vehicle with ACC and the adjacent lane (or the adjacent road) is too small, the ACC may respond to the vehicle and apply brake.

It is the driver's responsibility to determine and maintain a safe following distance at all times and never entirely rely on ACC to maintain an accurate following distance.

In uphill and downhill conditions, due to system restrictions, there may be some difference between the actual cruise speed and the set cruise speed of ACC. Adequate speed control may not be provided due to limited braking power and the hill conditions, and the distance between your vehicle and the vehicle ahead may be misjudged.

Use restrictions

ACC system relies on other systems, such as electronic stability control system. If any system stops its function, ACC system will be disabled automatically. In case of automatic disable, a sound signal will be sent and a message will be displayed on

the driver display. The driver must intervene to match the speed and distance with the vehicle ahead. The causes for automatic disabling may be:

- The driver opens the door.
- Then front compartment hood or trunk is opened.
- The driver unfastens his/her seat belt.
- The brake pedal is depressed.
- The vehicle is not in D gear.
- The motor speed is too low/too high.
- The wheel loses gripping force.
- The brake temperature is too high.
- Use the parking brake.
- ESC (Electronic Stability Control) function is activated.
- Automatic Emergency Braking (AEB) function is activated.
- ESC is disabled (namely, when ESC OFF is pressed, the ESC OFF indicator on the instrument cluster illuminates, and the ESC system is disabled).
- The vehicle has a collision.
- The camera has poor recognition capability due to direct sunlight or oncoming strong light.
- The camera or front millimeter-wave radar has a failure.
- The speed is higher than the maximum failure speed of 150km/h.
- The road curve radius is less than 250m.
- The trailer mode is activated.
- See "Camera" for camera restrictions.
- See "Radar" for radar restrictions.

Starting and Driving

ICA (Integrated Cruise Assist)

ICA (Integrated Cruise Assist) is used to assist the driver in maneuvering the vehicle on straight roads with clear lane lines on both sides and on roads with standard curvature, thus reducing the fatigue of the driver due to repetitive driving behaviors on long drives. This function can provide the driver with longitudinal and lateral control of the vehicle according to the traffic conditions in the driving direction. The longitudinal control can achieve constant speed cruise and vehicle following, while the lateral control is to control the vehicle near the center of the lane according to the left and right lane lines, providing a more relaxed driving mode for the driver.

ICA is to follow the vehicle ahead and keep the vehicle in the lane at the following time gap set by the driver. If the camera and the front millimeter-wave radar cannot detect any vehicle ahead, the vehicle will run still at the speed set by the driver. This can also happen if the vehicle ahead exceeds the set speed. If the camera cannot detect the lane ahead, the ICA function will be restricted and downgraded to adaptive cruise. When the speed is below 120km/h, the ICA (Integrated Cruise Assist) function can be activated. For ICA (Integrated Cruise Assist), the speed can be set at 0 to 120km/h.

Activation of integrated cruise assist

When the "ICA (Integrated Cruise Assist) indicator (grey)"



in the instrument cluster illuminates, it means the ICA (Integrated Cruise Assist) function is ready for your use.

In this state, you can press and hold the ACC master switch  to activate the ICA function.

After the ICA (Integrated Cruise Assist) function is activated, the "ICA (Integrated Cruise Assist) indicator (blue)"  in the instrument cluster illuminates.

Deactivation of ICA

If you need to exit the cruise manually, you may do it by pressing the ACC deactivation switch  or pressing the brake pedal. After exiting ICA, ICA indicator will change from blue to gray, or ACC indicator disappears.

Restoration of ICA

When ACC is activated and the "ICA (Integrated Cruise Assist) indicator (grey)" illuminates, long press the ACC master switch  to resume ICA.

Caution

ICA is not an anti-collision system. If the system does not detect the vehicle ahead, the driver must intervene. For intersections, the ICA may correct the steering wheel, requiring the driver to hold the steering wheel at the intersection and get ready to take over the vehicle.

Starting and Driving

Caution

For human or animals, as well as small vehicles such as bicycles, motorcycles, and electric vehicles, ICA does not brake. This includes flatbed trailers and approaching, slow-moving or stationary vehicles and objects.

ICA shall not be used in urban traffic, intersections, slippery surfaces, excessive water or mud on roads, cloudy days, rainy/snowy days, poor visibility, winding roads, or highway entrances and exits. This driver assistance system is not applicable to the scenarios where the sun shines from the front of the vehicle obliquely to the camera, where the vehicle enters and leaves the tunnel, and where the high beam of the opposite vehicle is shining on the camera at night.

If the lane line ahead changes direction rapidly, such as lane merging, road diversion and sudden increase or decrease of lane width, ICA may be exited. Please be sure to take over in advance.

ICA will occasionally assist the vehicle in steering when steering is not needed or when you do not intend to steer. It may be caused either by unclear or irregular lane lines, or by other lines or objects on the surface of the lane that resemble lane lines, in which case the driver should take over the vehicle in a timely manner.

Caution

When ICA system detects that the driver does not hold the steering wheel, it will issue a take-over request "Please gently turn the steering wheel" through the instrument cluster, and issue a take-over warning sound, accompanied by a flashing white light band. In this case, the driver should hold the steering wheel, and take over it if necessary to avoid risks. If the system detects that you have not taken over the steering wheel for many times, the function will exit automatically to ensure safe driving.

2

Use restrictions

The causes for automatic disabling may be:

- ACC function is exited or inhibited.
- Lane conditions or levels are not met.
- The driver operates the direction indicator lamp.
- The driver opens the door.
- Then front compartment hood or trunk is opened.
- The driver unfastens his/her seat belt.
- The brake pedal is depressed.
- The vehicle is not in D gear.
- The motor speed is too low/too high.
- The wheel loses gripping force.
- The brake temperature is too high.
- Use the parking brake.
- ESC (Electronic Stability Control) function is activated.

Starting and Driving

- Automatic Emergency Braking (AEB) function is activated.
- ESC is disabled (namely, when ESC OFF is pressed, the ESC OFF indicator on the instrument cluster illuminates, and the ESC system is disabled).
- The vehicle has a collision.
- The camera has poor recognition capability due to direct sunlight or oncoming strong light.
- The camera or front millimeter-wave radar has a failure.
- The speed is higher than the maximum failure speed of 130km/h.
- The road curve radius is less than 250m.
- The trailer mode is activated.
- See "Camera" for camera restrictions.
- See "Radar" for radar restrictions.
- The system will be inhibited in the following conditions:
 - If the vehicle ahead is braked suddenly, due to the restrictions of camera and the front millimeter-wave radar, the vehicle will be braked accidentally or not braked at all. If the lane line ahead changes from narrow to wide or from wide to narrow, the steering wheel may be corrected to a larger angle due to camera recognition restrictions and internal algorithmic logic.
 - ICA is mainly used on flat roads with clear lane lines. When driving with heavy load on steep downhill roads, it may be difficult for the function to keep the vehicle at a correct distance from the vehicle ahead, in which cases, you should take special care and always be ready to brake.
- On a road with sharp turns, such as a snake road, the ICA function cannot detect the vehicle ahead due to the limited field of view of the front millimeter-wave radar and the camera, which may cause the ICA to control the vehicle to accelerate, and require the driver to be ready to take over the vehicle at any time.
- If the distance between the vehicle with ICA and the adjacent lane is too small (or the vehicle in the adjacent lane is too close to the vehicle with ICA), the ICA may respond to the vehicle and apply brake. The driver should pay attention to the road changes and take over the vehicle in time.
- The performance of ICA on the ramp depends on the speed, load and gradient. When the vehicle runs uphill, it may be required to depress the accelerator pedal to maintain the vehicle speed. When the vehicle runs downhill, it may be required to brake or shift to a low gear to maintain the vehicle speed.

RCW (Rear Collision Warning)

RCW (Rear Collision Warning) monitors the targets behind the vehicle in real time through the rear radar, and sends an alarm message when a vehicle is detected rapidly approaching and posing a risk of rear-end collision.

Function enable/disable

Set it in the central control screen: Settings -> Advanced driver assistance -> Collision avoidance assist, and select to enable/disable the collision avoidance assist function.

If the switch is grey and cannot be used, please contact Our Service Dealer for service.

Message prompt

- Visual alarm
 - Text reminder messages: risk of collision.
- Audible alarm: entertainment system speaker alarm.

Caution

RCW cannot replace the role of rearview mirrors for rear observation. RCW is a driver assistance function, which will not provide assistance in all circumstances. RCW does not mean that the driver can relax. Please drive safely and cautiously.

Use restrictions

- RCW cannot provide accurate alarm in all scenarios, and unnecessary and missing warnings may be caused for many reasons: such as the impact of radar principle, a large volume of moving metal objects in blind spot, complex metal walls, etc.
- See "Radar" for radar restrictions.

Starting and Driving

Rear collision avoidance assist

By detecting the rear pedestrians, the system triggers the rear collision avoidance assist function to actively slow down the vehicle when there is a risk of collision between the vehicle and the rear pedestrians during reversing and the driver does not take measures.

During the activation of the rear collision avoidance assist function, for most drivers, it is not a normal driving style and they may feel uncomfortable. After the collision avoidance assist function successfully avoids a collision with the vehicle ahead, the vehicle will remain stationary for a short time and the driver should take action as soon as possible.

Generally, the driver or passenger only notices the collision avoidance assist function when the vehicle is about to have a collision. The rear collision avoidance assist function is activated when the driver should start braking early, but it can not help the driver in all situations.

Function enable/disable

Function enable method

When the vehicle is started, the collision avoidance assist function is enabled by default.

If you disable the function and then enable it again, you may set it in the central control screen: Settings -> Advanced driver assistance -> Enable collision avoidance assist.

Function disable method

Set it in the central control screen: Settings -> Advanced driver assistance -> Disable collision avoidance assist.

Message prompt

- Visual alarm
 - Indicator prompt messages: "AEB (Automatic Emergency Braking) warning lamp (red)"  flashes.
- Audible alarm: entertainment system speaker alarm.

Use restrictions

- The main detection targets of rear collision avoidance assist function are the rear pedestrians.
- Due to the limited detection area of radar, the rear collision avoidance assist function can not avoid all collision conditions.
- When the speed is more than 10km/h, the system does not function, and may be triggered occasionally at lower speed on congested roads, which may bring poor driving feelings.
- The driver must ensure that the seat belt is fastened, otherwise the rear collision avoidance assist function will not work.
- Ensure that the electronic stability system and the rear collision avoidance assist function are enabled, otherwise the rear collision avoidance assist function will not work.

- Some targets may affect and weaken the detection of sensor, such as road fences, tunnel entrances, rain or ice and snow, thus affecting relevant rear collision avoidance assist functions.
- The detection capability of cameras may be affected by bad weather, such as strong wind, heavy rain, fog, etc., which will reduce the system performance or increase the false trigger rate.
- See "Radar" for radar restrictions.

SLIF (Speed Limit Information Function)

SLIF (Speed Limit Information Function) is to use intelligent front view camera or maps to recognize speed signs and send relevant information to the instrument cluster, in order to remind the driver of the speed limit information on the current road and prevent overspeed. In this case, the system will not actively adjust the speed, and the driver should actively control the speed.

Function enable/disable

Set it in the central control screen: Settings -> Advanced driver assistance -> Speed limit information function, and select: enable/disable the SLIF.

Activation conditions

- The speed is less than 130km/h.
- The sensor signal is normal (camera).
- The speed limit sign is detected.
- The front view camera module at the front windscreen is not blocked/fogged, etc.

Note: After activated, the function will not work temporarily when the speed is more than 130km/h.

Alarm sound settings

Set it in the central control screen: Settings -> Advanced driver assistance -> Enable speed limit information function -> More -> Turn on or off the prompt tone.

Starting and Driving

Message prompt

After the function is enabled, if a speed limit sign is recognized, and the current vehicle speed is less than the speed on the speed limit sign, the instrument cluster will display the current speed limit value.

When a new speed limit sign is recognized, a "tick" reminder sound will be given first before the change of speed limit sign.

When the current vehicle speed is detected to be greater than the speed on the speed limit sign, the indicator corresponding to the speed limit sign will flash, accompanied by an audible alarm.



It indicates the speed limit value of the current road.

With the vehicle powered on, when a speed limit sign is detected,



the "conditional speed limit indicator" illuminates, please reduce the speed on the road in the corresponding direction to avoid overspeed.

When the system recognize a "conditional speed limit sign" but could not properly identify the condition (for example weather),



the speed limit sign will display adjacent to the regular speed limit information.

Caution

When the system can not recognize the speed limit sign information ahead, the instrument cluster will not display the speed limit sign information. The system only prompts the speed limit information, without controlling the speed of the vehicle. The system's recognition of speed limit signs is not completely accurate. For false recognitions, the driver should drive cautiously according to the actual road conditions.

Use restrictions

The traffic sign information function only works when the speed sign is clearly visible. It cannot work properly or may be inoperative in some circumstances. For example:

- The speed limit signs are in poor condition, such as faded, located on a curve, placed at an improper angle, rotated or damaged, completely or partially covered, too far or too high, and attached to road surfaces.
- The detection range of the camera is blocked when the vehicle runs too close to the vehicle ahead.
- The road or speed limit is changed recently, such as construction, traffic control, etc.
- Some LED speed limit signs.
- See "Camera" for camera restrictions.
- SLIF performance is limited by map coverage, which only covers the EU region.

Note: To ensure the performance of SLIF (Speed Limit Information Function), please upgrade your offline map in a timely manner so that the current time does not exceed one year after the offline map version was released. Method for viewing offline map version: Go to the Head Unit - System Information to view the offline map version number, for example, the version number EU_AL_20230216 indicates that 20230216 is the version release time.

ISA (Intelligent Speed Limit Assistance)

ISA (Intelligent Speed Limit Assistance) function is to use intelligent front view camera or maps to recognize speed signs and send relevant information to the instrument cluster, in order to control the current speed to comply with the speed limit information of the road and prevent overspeed. The system can actively adjust the speed only when the ACC function is enabled, and the driver should actively control the speed in other times.

2

Function enable/disable

Set it in the central control screen: Settings -> Advanced driver assistance -> Intelligent speed limit assistance, and select: enable/disable the ISA function.

Activation conditions

- The ACC function is activated.
- The sensor signal is normal (camera).
- The speed limit sign is detected.
- The front view camera module at the front windscreen is not blocked/fogged, etc.

Message prompt

After the function is enabled, if a speed limit sign is recognized, and the current vehicle speed is less than the speed on the speed limit sign, the instrument cluster will display the current speed limit value.

Starting and Driving

When the current vehicle speed exceeds the applicable speed limit by 9km/h or more, the system will send a pop-up prompt and change the ACC set speed upon the confirmation of the driver. When the driver presses SET- according to the pop-up prompt, ACC needs to cruise and decelerate based on the current speed limit value to Control the current vehicle speed. accompanied by an audible alarm. If the driver does not operate within 5 seconds, the current state will be maintained and ACC will not perform speed reduction. When the current speed is less than the speed indicated on the speed limit sign and at least 4km/h, the system will send a pop-up prompt requesting the driver to change the cruise target value. When the driver presses SET- according to the pop-up prompt, ACC needs to cruise and accelerate based on the current speed limit value. Control the current vehicle speed. If the driver does not operate within 5 seconds, the current state will be maintained and ACC will not perform acceleration processing. If the vehicle speed cannot be reduced to the speed on the speed limit sign within a specified time, the ACC indicator will flash yellow, accompanied by an audible alarm.



It indicates the speed limit value of the current road.

Caution

When the system can not recognize the speed limit sign information ahead, the instrument cluster will display the MIL state.

The system will only control the speed of the vehicle when the ACC function is active.

The system's recognition of speed limit signs is not completely accurate. For false recognitions, the driver should drive cautiously according to the actual road conditions.

Use restrictions

The traffic sign information function only works when the speed sign is clearly visible. It cannot work properly or may be inoperative in some circumstances. For example:

- The speed limit signs are in poor condition, such as faded, located on a curve, placed at an improper angle, rotated or damaged, completely or partially covered, too far or too high, and attached to road surfaces.
- The detection range of the camera is blocked when the vehicle runs too close to the vehicle ahead.
- The road or speed limit is changed recently, such as construction, traffic control, etc.
- Some LED speed limit signs.
- See "Camera" for camera restrictions.

IHC (Intelligent High beam Control)

IHC (Intelligent High beam Control) recognizes the traffic environment ahead through the front view camera, automatically controls the low and high beam switching, prevents dazzling to the vehicles ahead and oncoming vehicles, and improves the safety and comfort of the driver in the dark environment, especially at night.

Function enable/disable

Function enable method

Set it in the central control screen: Exterior lamps-> Lamp settings -> Turn on IHC switch.

Function disable method

The IHC can be turned off in two ways:

- Long press the lever switch of high beam headlamp and direction indicator lamp for more than 3 seconds towards the steering wheel.

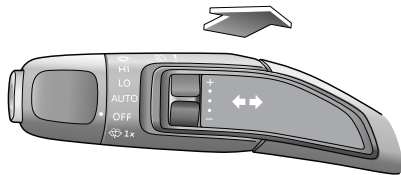

- Set it in the central control screen: Exterior lamps-> Lamp settings -> Turn off IHC switch.

Activation conditions

- The speed is higher than 40km/h.
- The lamp control switch is positioned in AUTO position.
- The low beam headlamp  has illuminated.
- The front view camera module at the front windscreen is not blocked/fogged, etc.

Note: After activated, the function does not work temporarily when the speed is below 25km/h.

Message prompt

After the IHC function is enabled, its working state can be observed by the IHC indicator on the instrument cluster.



When the "IHC indicator (blue)"  illuminates, it indicates that the conditions to turn on the high beam headlamp are met, and the system will automatically turn on the high beam headlamp.



When the "IHC indicator (grey)"  illuminates, it indicates that the conditions to turn on the high beam headlamp are not met, and the system will automatically turn off the high beam headlamp.

Starting and Driving

Caution

The front view camera module is installed on the front windscreen. It should be noted that the camera's field of view cannot be blocked by objects, which will affect its function.

IHC function can not accurately perceive the surrounding environment, which may cause the incorrect adjustment of the high beam/low beam. Please observe the local traffic regulations and use the function in a reasonable manner.

IHC is only a comfort function, and the driver needs to drive cautiously when using the function.

- The performance of IHC will be degraded in bad weather conditions, such as wind, sand, heavy rain and fog.
- See "Camera" for camera restrictions.

Use restrictions

- IHC function will be restricted by camera conditions and various restraint conditions.
- The performance of IHC will be degraded if the front view camera module has not been calibrated properly.
- The performance of IHC will be degraded by the limitation of field of view due to dust covering, rain, snow, fog, icing and other factors.
- The performance of IHC will be degraded due to the interference of the ambient light source.
- The performance of IHC will be degraded if there is any highly reflective object in the perception range of the front view camera module during driving.
- When ABS or ESC function is activated, the high beam/low beam will not be switched.

Starting and Driving

BSD and LCA (Blind Spot Assist)

Blind spot assist includes two active safety assist functions, BSD (Blind Spot Detection) and LCA (Lane Change Assist). When the subsystem detects that a vehicle is approaching at a high speed in the blind spot of the rearview mirror or from a distance, the system will warn the driver through the LED light on the left and right external rearview mirrors.

Function enable/disable

Set it in the central control screen: Settings -> Advanced driver assistance -> Blind spot assist, and select: enable/disable the blind spot assist function.

If the switch is grey and cannot be used, please contact Our Service Dealer for service.

Caution
When the blind spot assist function is enabled, if the "BSD (Blind Spot Detection) and LCA (Lane Change Assist) warning light (yellow)"  stays on, please contact Our Service Dealer for service.

Monitoring diagram



Area ① about 7m behind the vehicle's blind spot; Area ② about 70m behind the vehicle's blind spot.

Blind spot refers to the visual blind spot behind the left and right rearview mirrors of the vehicle (as shown in Figure ① below). If there is a vehicle in this area, this function will give a favorable prompt to the driver to avoid collision risk caused during turning or lane change.

If there is a vehicle running at a high speed (much faster than the vehicle) in the area shown in the following Figure ②, this function will give a favorable prompt to the driver to avoid collision risk during turning or lane change.

Warning and prompt

When the vehicle runs at a speed of more than 15km/h, if there is a vehicle in Area ① or there is a vehicle approaching at a high speed in Area ②, the system will actively prompt the driver, and

Starting and Driving

the indicator on the corresponding side will illuminate, as shown in the figure below.

If the driver has the intention to change lanes or make a turn (by turning on the direction indicator lamp on the side with a vehicle), the indicator on the corresponding side flashes to warn the driver.

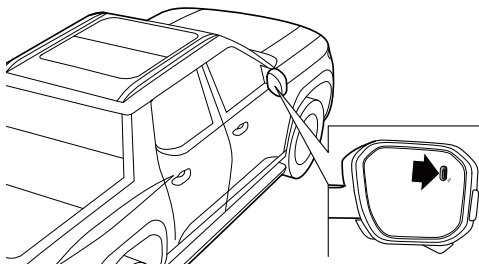

Caution

In emergency turning, the BSD and LCA will not provide warning.

The blind spot assist is a driver assistance function, which will not provide assistance in all circumstances.

The blind spot assist works with the left and right rearview mirrors to provide better assistance, but can not replace the role of rearview mirrors for rear observation.

If the indicator of the exterior rearview mirror stays on, please contact Our Service Dealer for service.

Use restrictions

- BSD cannot provide accurate alarm in all scenarios, and unnecessary and missing warnings may be caused for many reasons: such as the impact of radar principle, a large volume of moving metal objects in blind spot, complex metal walls, etc.
- The driver shall remain alert while driving, always pay attention to road conditions, and be sure to change lanes in safe conditions.
- See "Radar" for radar restrictions.

RCTA (Rear Cross Traffic Alert)

RCTA (Rear Cross Traffic Alert) is a driver assistance function, which warns the driver of the vehicles running laterally on left and right sides or the crossing pedestrians when the vehicle is reversing. The speed range of the RCTA function is between 0 and 10km/h.

Function enable/disable

Set it in the central control screen: Settings -> Advanced driver assistance -> Blind spot assist, and select: enable/disable the blind spot assist function.

If the switch is grey and cannot be used, please contact Our Service Dealer for service.

Monitoring diagram

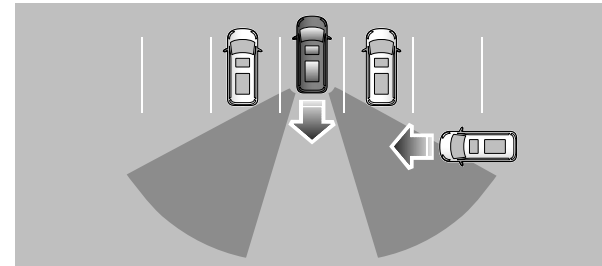
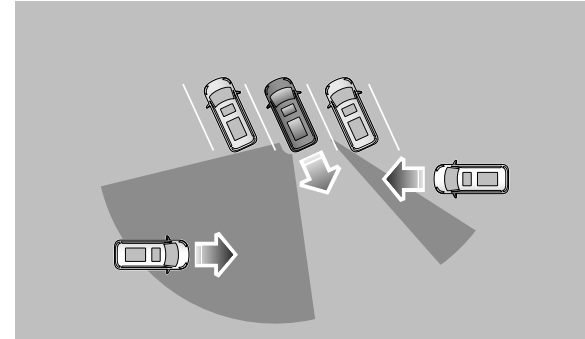
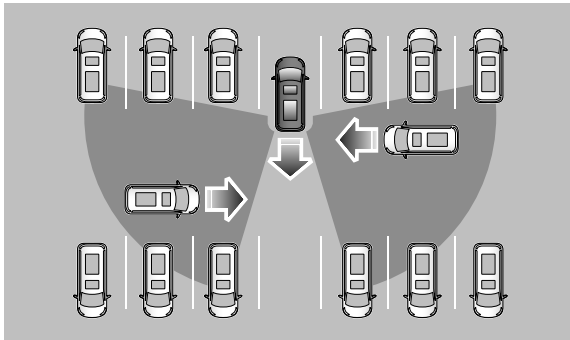

Warning and prompt

When the vehicle is in reverse mode (R gear), if there are vehicles and pedestrians moving laterally on either side behind the vehicle, the indicator of the rearview mirror on the corresponding side will flash, accompanied with prompt tone to alert the driver

Starting and Driving

Caution

RCTA cannot replace the role of rearview mirrors for rear observation.

RCTA is a driver assistance function, which will not provide assistance in all circumstances.

RCTA does not mean that the driver can be relaxed, and it is the driver's responsibility to reverse in a safe manner.

Use restrictions

- RCTA cannot provide accurate alarm in all scenarios, and unnecessary and missing warnings may be caused for many reasons: such as the impact of radar principle, a large volume of moving metal objects in blind spot, complex metal walls, etc.
- The driver shall remain alert in reversing, always pay attention to road conditions, and be sure to reverse in safe conditions.
- See "Radar" for radar restrictions.

DOW (Door Open Warning)

When the vehicle is stationary and not in R gear, the DOW function can detect the vehicles, cyclists or pedestrians and other targets approaching the vehicle from behind. If the driver or passenger opens the door when an approaching target is detected, the DOW will issue a warning prompt, so that the driver and passenger can avoid opening the door, preventing scratches with the targets.

Function enable/disable

Set it in the central control screen: Settings -> Advanced driver assistance -> Blind spot assist, and select: enable/disable the blind spot assist function.

If the switch is grey and cannot be used, please contact Our Service Dealer for service.

Monitoring diagram

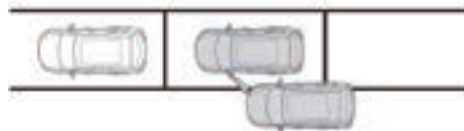

Warning and prompt

When a target is approaching the stationary vehicle, the DOW function will turn on the warning indicator, in which case the

Starting and Driving

driver or passenger should avoid opening the door, but confirm whether it is safe to open the door first.

If the driver or passenger opens the door on the warning side, the warning indicator will flash, a corresponding pop-up window will be displayed and prompt sound will be given on the instrument cluster and the door ambient light on the corresponding side will illuminate to remind the driver or passenger to open the door safely.

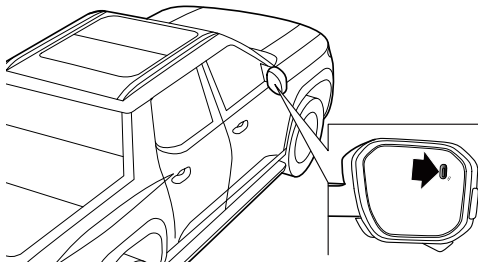

Caution

DOW is a driver assistance function, which cannot work in all conditions, or replace the role of rearview mirrors for rear observation.

DOW function may send unnecessary or missing alarm when limited to the sensor principle and the complexity of the traffic environment. The most effective measure to guarantee the personal safety of driver and passenger is to actively observe the door opening environment before getting off the car.

2

Use restrictions

- DOW function is valid only when the vehicle is stationary and not in R gear, and it will not work when the vehicle is moving.
- This function can be activated only when the vehicle is not in R gear and the speed is less than 3km/h. It gives alarms only when the speed of target vehicle is greater than 10km/h.
- DOW cannot work in all conditions, and it may give unnecessary or missing warning for many reasons, such as there is a smaller or stationary target behind the vehicle; or other vehicle changes lane suddenly to the adjacent detection area of the vehicle.

The above warnings and restrictions do not represent all conditions that may interfere with DOW. To avoid scratches during door opening, the driver and passenger should always observe if it is safe and appropriate to open the door.

Starting and Driving

Driver state monitoring

Note: *It applies to vehicles configured with driver monitoring system (DMS).*

The DMS provides the functions of driver fatigue detection, driver distraction detection, driver smoking behavior detection and driver phone use behavior detection for the driver through the camera which is installed on the steering column of the steering wheel as well as the "Algorithms for human face and fatigue" built in the entertainment mainframe.

Enter Settings -> Click on the driver status monitoring switch , which can control the alarm display of all functions as a whole, and can meanwhile individually control the prompts for various functional alarms.

Driver fatigue detection

When the driver is fatigued to some extent, the DMS will estimate the fatigue degree of the driver through common fatigue behaviors such as yawning, eyes closing, etc., and conclude the fatigue degree of the driver through estimated results. If the fatigue degree exceeds a certain standard, the DMS will remind the driver through pop-up window and alarm on the instrument pack. To ensure driving safety, when the driver has fatigue behaviors, the DMS will actively activate the functions of collision assist and lane assist and adjust the sensitivity of the corresponding function. When turning off the switch for driver fatigue monitoring, only instrument pop ups and alarms will be turned off.

This function will work with the vehicle speed not less than 10km/h, and distinguish mild fatigue, moderate fatigue and severe fatigue.

Driver distraction detection

When the driver gazes around during normal driving, the DMS will assess the overall focus direction of the driver according to the overall angle and time of head rotation or the direction and time of line of sight deviation of the driver, so as to judge the driver's distraction behavior. The system will remind the driver through instrument panel pop-up windows and alarm sounds. It should be noted that, due to existence of time assessment, observing rearview mirrors and on-board mainframe for a short period of time will not trigger the distraction detection. To ensure driving safety, when the driver has distraction behaviors, the DMS will actively activate the function of collision assist and adjust the sensitivity of the corresponding function. When the switch for driver distraction monitoring is turned off, only the instrument pop-up window and alarm will be turned off.

In addition, this function will be temporarily turned off to avoid misjudgment when it's required to call the body camera to project the scenarios to the on-board mainframe under circumstances like reversing.

This function will work with the vehicle speed not less than 10km/h.

Driver smoking behavior detection

When the DMS detects the smoking behavior of the driver during driving, the driver will be reminded through pop-up window and alarm on the instrument pack. This function will work with the vehicle speed not less than 10km/h. When the switch for monitoring driver smoking behavior is turned off, only the instrument pop-up window and alarm will be turned off.

Driver phone use behavior detection

When the DMS detects that the driver answers the phone with a hand during driving, the driver will be reminded through pop-up window and alarm on the instrument pack. This function will work with the vehicle speed not less than 10km/h. When the switch for monitoring the driver's phone behavior is turned off, only the instrument pop-up window and alarm will be turned off.

CPD (Child Presence Detection)

With the vehicle locked and powered off, when the possibility of a child being left behind is detected in the front passenger seat or the rear row, the CPD function will alert by flashing the turn signal lamp during 5 seconds.

Function ON/OFF method

The CPD function can be turned on or off via a switch on the center control screen. When the function is turned off or the vehicle is powered off, the "CPD function OFF indicator light

(yellow)"  on the instrument cluster will illuminate. After turning off the CPD function on the center control screen, the function will be turned on by default the next time the vehicle is powered on.

If you need to turn off the CPD function for a long time, please contact Our Service Dealer. After the CPD function is turned off for a long time, when the vehicle is powered on/off, the "CPD

function OFF indicator light (yellow)"  on the instrument cluster will illuminate.

Caution

When the CPD function judges that there is a possibility of child presence, an alarm reminder will be issued only as an auxiliary reminder, not a direct monitoring, and the possibility of false alarm and non-alarm is not excluded.

Starting and Driving

Tires



DEFECTIVE TIRES ARE DANGEROUS!

Do NOT drive your vehicle if any tire is excessively worn, damaged or inflated to an incorrect pressure.

Do NOT overload vehicle.

Incorrect tire inflation pressures or an unbalanced wheel and tire assembly can seriously affect the stability, especially when driving with high payloads or at high speeds. Under-inflation will increase rolling resistance and accelerate tire wear, resulting in tire damage, even an accident.

Always drive with consideration for the condition of the tires; the most common causes of tire failure are:

- Bumping against curbs.
- Driving over deep pot holes.
- Tire under-inflation or pressure overload during driving.

Uneven tread wear can be caused by faulty wheel alignment.

Winter tires



The vehicle speed shall not exceed the maximum allowable speed of the installed winter tires, otherwise the tires may suddenly lose pressure, delaminate, or even burst, which may easily cause accidents!

Be sure to adjust the speed according to the specific climate, roads and traffic conditions. Do not take risks by taking advantage of the anti-skid performance provided by winter tires and beware accidents!

Winter tires can improve the handling stability and braking performance of the vehicle when driving in a low temperature environment or on icy roads. It is suggested that winter tires should be used when the temperature is lower than 7°C.

When a vehicle is running under winter road conditions, winter tires can greatly improve the handling stability and braking performance. Non-winter tires have poor skid resistance at low temperatures or on icy roads due to their structure (tire width, rubber composition, pattern type, etc.).

It is recommended to use winter tires of the same size and load index as that of the original tires, and all the four wheels shall use winter tires.

When the tread depth of winter tires is worn to 4mm, the skid resistance will decrease obviously.

Starting and Driving

The maximum allowable speed of winter tires shall be subject to the speed code on the tires.

Speed symbol	Maximum speed (km/h)
C	60
D	65
E	70
F	80
G	90
J	100
K	110
L	120
M	130
N	140
P	150
Q	160
R	170
S	180
T	190
H	210
V	240
W	270
Y	300

In addition, it is recommended to set the overspeed alarm, which can be controlled to turn on or off via the touch button on the center console screen.

When the temperature rises above 7°C, it is recommended to replace winter tires with non-winter tires.

Anti-skid chain

When driving a vehicle in the snow, it is recommended to apply S anti-skid chain to the driving wheels.

The anti-skid chain could increase the traction when driving on roads in winter. If you want to install the anti-skid chain, please remember that:

- 1 Not all wheels and tires are suitable for an anti-skid chain.
When installing anti-skid chains, only approved tire size can be used.
- 2 Install anti-skid chains on the drive wheels. Please follow the instructions of anti-skid chain manufacturer.

It is just in the snow that you can drive the vehicle at maximum speed allowed by the anti-skid chain. Please comply with the regulatory requirements of the resident country. Remove the anti-skid chain immediately when driving on the snow-free road.

Starting and Driving

Loading

It is the driver's responsibility to ensure no overload in accordance with the laws.

Note: *The maximum allowed total mass is indicated on the vehicle identification plate which is located in the lower front of on the B pillar. This Handbook introduces the correct vehicle weight parameters, see "Vehicle weight parameters" in General Technical Parameters section.*

Load carrying

Goods shall be placed between both axles and neither deviate to the front axle loading area nor the rear axle loading area. Heavier goods shall be distributed evenly, and the heaviest goods shall be placed between both axles.

Caution

During the driving of the vehicle, the tailgate shall not be opened. When the vehicle is stopped, the total weight of people or goods on the tailgate shall be controlled below 200kg when using the tailgate to get on and off and load and unload goods. When the vehicle is stationary or in motion, the tailgate must not be used for loading goods.

Hazardous loads

There is a legal requirement to display a specific type of external warning sign on the vehicle if certain hazardous goods are being carried.

Load restraint

! Secure all loads in the vehicle to prevent personal injury due to movement of loads.

Note: *The driver is obliged to ensure all goods have been fixed correctly.*

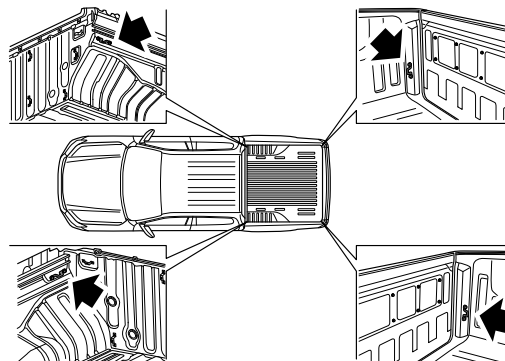

Cord hook (strapping ring) in the container can withstand the maximum vertical and 45 ° tensile force of 1500N.

Cargo box rail/rope hook

Note: It applies to vehicles configured with the cargo box slide rail/rope hook. You can choose the cargo box slide rail or the cargo box slide rail plus rope hook, if you only choose the cargo box slide rail, you need to purchase rope hook related products by yourself.

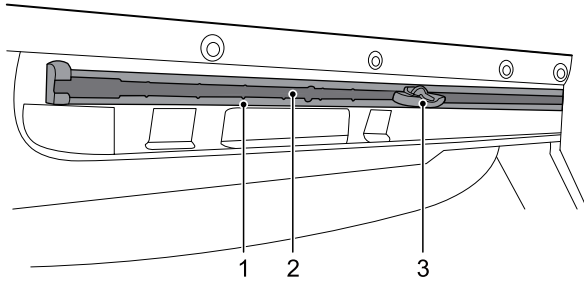

- 1 Limiting groove
- 2 Slide rail
- 3 Rope hook

Before fixing the cargo, you need to move the rope hook (3) into the semi-circular limiting groove (1) at the upper and lower position of the cargo box slide rail (2), and then tighten the rope hook knob clockwise (at the arrow in the figure below). If you need to move the rope hook, turn the knob counterclockwise (at the arrow in the figure below), loosen it and then press the knob toward the outside of the vehicle to move the rope hook back and forth.

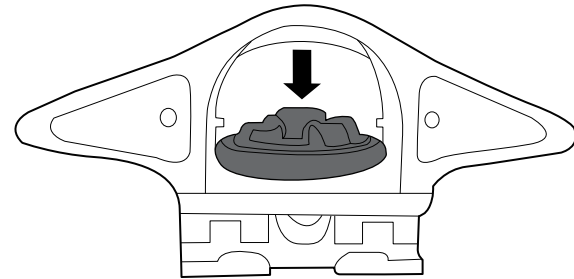

Caution

Maximum tensile load of 1000N when the rail of one side is perpendicular or 45° to the rope hook.

This device is intended for securing cargo in the container only, and is not to be used for towing operations etc.

Do not exceed the maximum load rating of the load securing device.

Before using the device, check that the rope hook is correctly fixed and that it is not damaged.

Starting and Driving

Roof rack and load device



Be sure to place your luggage properly on the roof rack, otherwise accidents may occur. Under any circumstances, the maximum roof load, maximum axle load or maximum total vehicle load shall not be exceeded, otherwise accidents may occur. The roof rack with loaded items will reduce the vehicle stability, especially during turns and crosswind. When placing heavy or bulky luggage on the roof rack, the centroid position deviation of the vehicle and the wind resistance may affect the vehicle's drivability and cause accidents. Under this circumstances, you should adjust the driving mode and speed according to the actual situation. Off-road driving with items on the roof rack is not recommended.

The drivability of the vehicle may be affected by the loading items. Only the rack system designed for your vehicle can be fitted. Please consult Our Service Dealer for more information.

For the roof rack system of aluminum alloy approved by our company, the maximum load capacity during driving is 50 kg. The weight of the approved rack system is not included in the loading capacity.

If other roof rack system is used, the system's own weight must be included in the loading capacity.

The loading items must be distributed evenly and not suspended on the rack. Check the connection between the rack and the loading items after driving 50 km.

Trailer towing

Note: *It applies to vehicles configured with the trailer towing.*

Instructions of trailer towing

The vehicles are designed for use primarily as a passenger and load bearing vehicle. Towing a trailer may create adverse effects on a number of factors including handling, durability, performance and braking. We recommend for the safety of yourself, your passengers and others that the vehicle and trailer is not overloaded.

The warranty does not cover any damages caused by or relating to towing a trailer.

- Weight limits

Establish that gross vehicle weight, trailer tow ball down load, trailer weight and axle weights are all in accordance and not exceeding their individual limits.

- Gross vehicle weight

Please refer to your vehicles data label for reference on what gross vehicle weight must not be exceeded.

Gross vehicle weight is the combined weight total of the trailer towbar, unloaded vehicle, driver, luggage and passengers. This also includes the weight of any accessories or equipment added to the vehicle.

Instructions before use

- The state specific trailer towing regulations must be followed.
- The vehicle speed should not exceed 100km/h. When driving on complex road conditions (requiring frequent lane changes and turns), it is recommended that the maximum speed should not exceed 80km/h. The stability and operational flexibility of the vehicle are reduced when it is in a towed state. When driving on unsafe road conditions, the vehicle speed needs to be reduced, and there should be margin outside the emergency handling distance.
- It is suggest using trailers equipped with sway dampers.
- It is only applicable to center axle trailers, and the load specified in "Recommended towing weight" shall not be exceeded when towing trailers.
- When a new vehicle has been driven or a vehicle has had powertrain parts changed to new parts, it is recommended not to tow a trailer until the driving distance reaches 800km.
- Place the load as close as possible to the trailer axle, fix it securely and place it as low as possible, while ensuring that the towing weight and the load allowed by the tow ball are not exceeded (Refer to "Recommended towing weight" for details). For best stability of the trailer in an unladen vehicle, place the load in the trailer towards the nose within the maximum nose load (Refer to "Recommended towing weight" for details), as this gives the best stability.
- The specified trailer loads are only applicable to an altitude less than 1,000 m. As the air density decreases with the altitude increase, causing the drive motor output and grade

Starting and Driving

ability to drop, the total mass must be reduced by 10% when the altitude increases by 1,000 m.

- The tires of towing vehicle shall be adjusted to the specified pressure, and the pressure of trailer tires shall also be checked, and on the rear tire pressure, at least 20kPa(0.2bar) above the tire pressure as recommended for normal use (i.e. without a trailer attached).
- If the traffic conditions behind the trailer are invisible through the standard outside rear view mirrors, two additional rear view mirrors must be installed on the reversible boom and adjusted to ensure sufficient rear view at any time.
- The headlamps shall be checked and adjusted if necessary after a trailer is hitched up.
- Always use a safety chain that is suitable for your vehicle and trailer. Have the safety chain passing through the hole at the lower part of the hitch and attach it to the trailer. The safety chain will prevent the trailer from dropping to the ground in the event that the hitch disengages. For proper use and installation, consult the trailer manufacturer.
- When mechanical coupling device, whether fitted or not, could (partly) obscure the space for mounting and fixing the rear registration plate, the following shall apply:
 - 1 Installation of a mechanical coupling device that cannot be easily removed or repositioned is not permitted.
 - 2 A mechanical coupling device must always be removed or repositioned when it is not in use.

Instructions for driving

- Before driving, check all the safety equipment to ensure safe operation. Ensure that the vehicle is properly maintained to avoid mechanical failure.
- Avoid non-loaded towing vehicle and loaded trailer as much as possible when driving. If it is inevitable, drive at low speed due to improper load distribution.
- As the driving stability of towing vehicle and trailer drops with the speed increase, the speed shall be as low as possible without exceeding the specified speed limit under the improper road, weather and strong wind conditions, especially when driving on a slope.
- When the trailer sways, grip the steering wheel firmly to drive straightforward, and release the accelerator pedal to decelerate the vehicle slowly. Do not attempt to eliminate sway by turning the steering wheel or by emergency braking. The higher the speed, the stronger the trailer swaying. If the sway is still not eliminated after deceleration, stop the vehicle to check if the trailer weight distribution is even and the trailer device is installed securely.
- Under any conditions, the vehicle must be decelerated immediately once minor sway is noticed on the trailer, and never try to eliminate the sway through acceleration.
- If an inertia brake is installed on the trailer, first brake slowly and then brake rapidly when braking is required. This can avoid braking impact due to trailer wheel locking.
- Clean, dry and flat concrete or asphalt (or similar) pavement is required for towing.

Starting and Driving

Trailer control module

The trailer control module provides actuation functions for the width lamp, brake lamp, reverse lamp, turn signal lamp and rear fog lamp of the trailer. The trailer control module automatically identifies if a trailer is connected by the trailer detection.

Activate the parking brake and turn off the vehicle power. Connect the trailer; refer to "Installation of Trailer Device" for details. Connect the trailer wiring harness. The harness connection points are as shown below. If the trailer wire harness is required, please contact our Service Dealers.

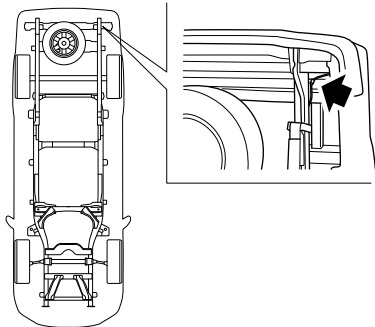

With the vehicle powered on, when the trailer is connected successfully, when the turn signal lamp is turned on, "trailer

indicator (green)"  on the instrument cluster flashes.

When the trailer connection fails, "trailer indicator (green)" on the instrument cluster goes off.

Caution

- The width lamp, turn signal lamp or both of them on the trailer must be halogen lamp. Otherwise, it may be misjudged that the trailer is not connected, and normal operation of reverse radar system will be affected.
- With the vehicle powered on, the trailer lamps may flash instantaneously. This is normal as the system is conducting self-check.

Note: For models with air suspension system, the suspension height may change after the trailer wiring harness is connected, please see "Air suspension system" in this section.

Starting and Driving

Recommended towing weight

Towing capacity

Driving type	GVW (kg)	CVW (kg)	ATM (braked trailer) (kg)	GTM (kg)
4x2	3500	2750	3500	6500
4x4	3500	2850	3500	6500
4x4	3500	2880	3500	6500

Caution

- The sum of gross vehicle weight (GVW) and aggregate trailer mass (ATM) shall not exceed the specified gross train mass (GTM) of the vehicle.
- ATM(unbraked trailer) is 750kg.

Trailer nose weight

Caution

Never exceed the maximum allowable nose weight, such as the vertical weight on the ball of the trailer. This is very important for the stability of the vehicle and trailer. The technically permissible maximum nose weight shall not be less than 4% of ATM and not be less than 25kg. The maximum nose weight is $\leq 10\% \cdot \text{ATM}$.

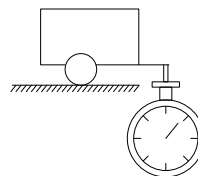

Variant	Maximum Nose Weight
All models	220 kg

Starting and Driving

Installation of trailer device

- 1 The trailer device is installed at the rear of the frame, and it shares the installation point with the rear bumper bracket. The bolt quantity is 3 on one side, 6 per vehicle, and the bolt tightening torque is $130\pm 10\text{Nm}$. If you need a towing device, please contact our Service Dealers.

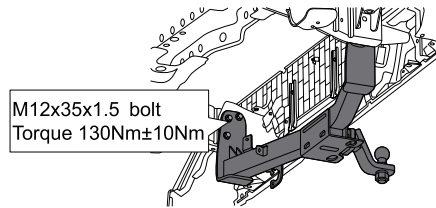

- 2 The assembly sequence of the trailer device parts is as follows. The parts have been assembled before leaving the factory. If you have any assembly requirements, please follow this operation.

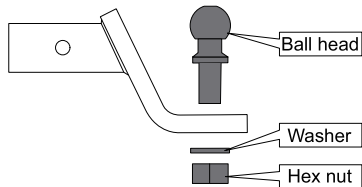

- Step 1: insert Ball head.
- Step 2: put in Washer.
- Step 3: put in Hex nut locking: M24X1.5, Torque: $300\text{Nm}\pm 20\text{Nm}$.

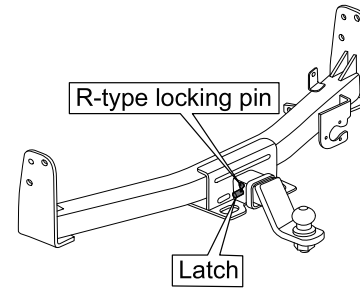

- Step 4: put in Latch.
 - Step 5: insert R-type locking pin.
- 3 Please use a trailer device that meets the requirements of ECE R55 Mechanical Coupling Components of Combinations of Vehicles. Different models of trailer devices should be selected according to the vehicle configuration to meet the towing requirements. If you want to learn more information, please contact your local Service Dealers.

Starting and Driving

- Type 1

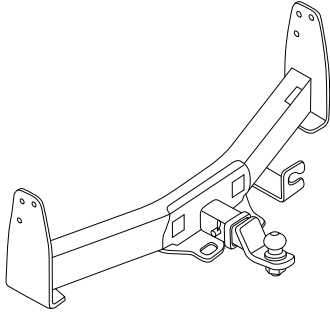

- Type 3

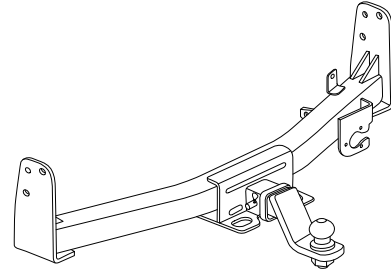

- Type 2

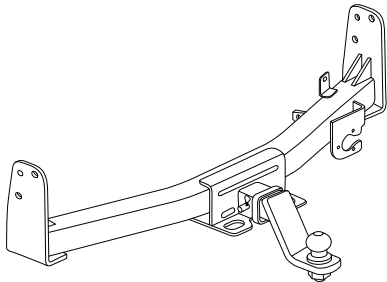

- 4 For models with air suspension configuration, the trailer device needs to be adjusted to "Towing mode" for installation and use in conjunction with the suspension. See "Air suspension system" in this section for more instructions.

Starting and Driving

- 5 There are anti sway bolts and nuts under the trailer arm. When towing, they need to be loosened. First loosen the nut, then loosen the bolt. After the bolt moves down by about 3 ~ 5mm, tighten the nut again. When not in a towing state, it is necessary to tighten the bolts and nuts to avoid abnormal noise caused by the trailer arm shaking inside the trailer bar. Loosen the nut first, then install the bolt until the end of the bolt is in contact with the lower surface of the trailer arm, and then tighten the nut again.

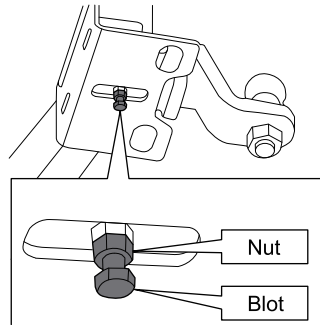

Maintenance

If the vehicle is commonly used for towing trailers, additional maintenance should be carried out on the vehicle during maintenance intervals, regular inspections should be conducted, and bolts and nuts should be tightened according to the assembly torque specified in the installation instructions to ensure continuous satisfaction with the vehicle.

The ball joints, washers, and nuts on the trailer arm are made of stainless steel and require regular cleaning and maintenance. They can be wiped with a sponge or towel to maintain cleanliness as soon as possible. After long-term use, wear and tear of parts cannot be avoided, and surface rust may appear. Sponge or towel dipped in neutral cleaner, soapy water or rust remover can be used to wipe and remove it. After treatment, it is necessary to thoroughly rinse with water. Pay attention to wearing protective gloves during the cleaning process.

Emergency Troubleshooting

210 Emergency Door Opening or Closing

212 Hazard warning lamp

212 Warning triangle

213 Wheel replacement

218 Towing a vehicle

220 Jump start

222 Fuse replacement

230 Bulb replacement

Emergency Troubleshooting

Emergency Door Opening or Closing

Emergency door opening inside the vehicle

Open the emergency door pull ring cover located below the vehicle door, pull the pull ring once to open the door.

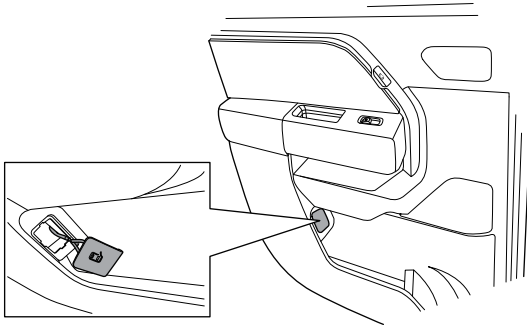

Caution

When the child lock is in the locked state, both the door opening switch and the emergency door pull ring cannot open the door from the inside.

Manually unlock and lock the driver door

When the vehicle is powered off or the doors can not be unlocked or locked electronically, the driver door can be unlocked and locked manually.

- 1 Pull the driver door handle to lift the rear end of the door handle to the maximum opening and expose the lock cylinder.
- 2 Use the mechanical key portion to manually lock and unlock the driver door through the lock cylinder on the driver door. The mechanical key portion rotates clockwise to lock and counterclockwise to unlock. After completing the action, the mechanical key portion needs to be pulled out to allow the door handle to rebound to its initial position before closing the door or pulling the door handle to open the door.

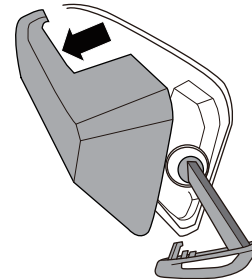

Emergency Troubleshooting

Manually lock the front occupant door and rear doors

When the vehicle is powered off or the doors can not be locked electronically, the front occupant door and rear doors can be locked manually.

For the left door, rotate the toggle in the position shown counterclockwise with a mechanical key, and for the right door, rotate the toggle in the position shown clockwise with a mechanical key, then either door can be locked by closing it.

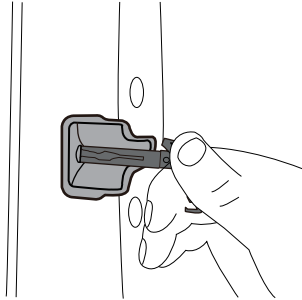

Open the driver and passenger side doors, pull the interior door emergency door pull ring once, and open the current door; To open the rear side door, you need to pull the interior door emergency door pull ring once when the child lock is unlocked to open the current door.

Caution

When the child lock is in the locked state, both the door opening switch and the emergency door pull ring cannot open the door from the inside.

Emergency Troubleshooting

Hazard warning lamp

When you encounter a problem during driving and have to stop the vehicle or slow down, you shall press the hazard warning lamp switch (1)  on the central control switch group, the "direction indicator (green)" on the instrument cluster will illuminate and flash, meanwhile all the turn signals flash to alert others and make the police know you are in trouble.

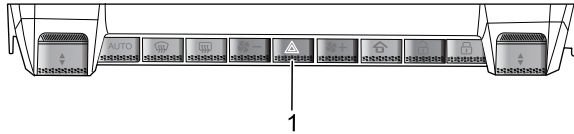

Warning triangle

The warning triangle is placed on the flat floor behind the second-row left seat. For models equipped with the openable rear quarter, the warning triangle is located below the second-row right seat.

When you encounter a problem during driving and you have to pull the vehicle over, if the situation permits, on the conventional road, please place a warning triangle about 50 ~ 150m right behind the vehicle to alert vehicles behind; On highways, a warning triangle should be placed about 150m right behind the vehicle; in rainy and foggy day with low visibility, place the warning triangle about 200m right behind the vehicle, to alert vehicles behind.

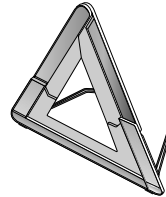

Emergency Troubleshooting

Wheel replacement

Jack

Placement

The jack is placed on the flat floor behind the second-row left seat. For models equipped with the openable rear quarter, the jack is located on the sloping floor behind the second-row left seat.

Specifications

 **This jack is just for wheel replacement. Never use it for other purposes.**

This jack is just for your vehicle and never uses it for other models.

For models with air suspension, the air suspension maintenance mode must be enabled before lifting the vehicle. For the enable method, please see "Air suspension system" in the Starting and Driving section.

Spare tire

 **Check the pressure of the spare tire regularly. Using a spare tire of incorrect tire pressure will affect the wheel stability, which may cause danger and permanent damage to the wheel.**

The spare tire is mounted at the rear bottom of the body; the wheel nut wrench in the vehicle tool kit can be used to rotate the pillar bolt of drive mechanism, thus releasing or tightening the rope for the spare wheel to achieve the function of spare tire replacement.

Removing spare tire

- 1 Rotate the securing bolt of the jack to take out the jack and the other tools. For models equipped with the openable rear quarter, the other tools are located below the second-row right seat.

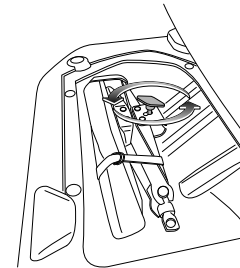

Emergency Troubleshooting

- 2 Mount the auxiliary rotary post and the wheel nut wrench.

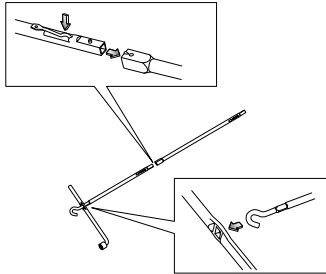

- 3 Press the left end of the cover with hand and then open the rear bumper cover.

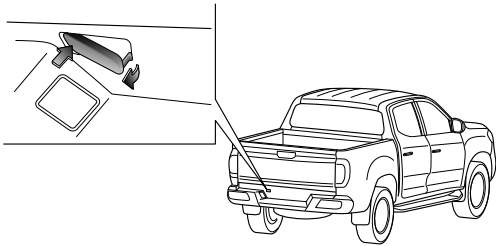

- 4 Insert the auxiliary rotary post into the spare tire loading/unloading hole through the cover, and then rotate the wheel nut wrench counterclockwise to lower the spare tire till the tire lands on the ground.

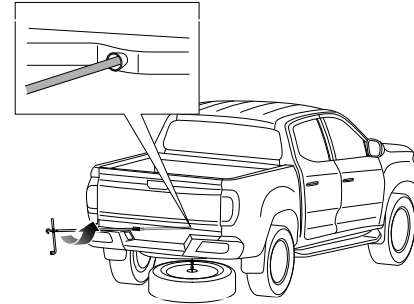

- 5 After the spare tire lands on the ground, continue to rotate the wheel nut wrench counterclockwise and, at the same time, pull out the spare tire. Excessive rotation of the wrench is prohibited, or the spare tire device will be damaged.
- 6 Remove the tray from the spare tire.

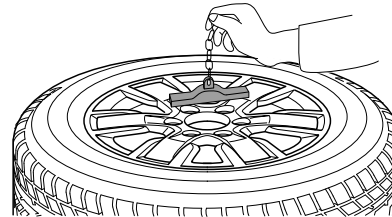

Emergency Troubleshooting

Storing the spare tire

- 1 Place the wheel on the ground with the air valve facing up.
- 2 Place the wheel at the rear bottom of the vehicle.
- 3 Place the spare tire tray in the center of the rim, and adjust it to the proper position to make it tightly connected to the spare tire.

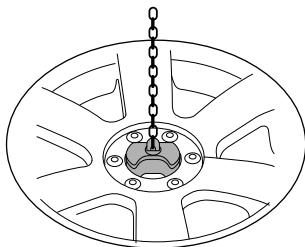

- 4 Rotate the wheel nut wrench clockwise till the nut is tightened.

Caution

After placing the wheel on the spare tire holder, check whether the wheel mounting is tight. If the wheel is loose, it may fall off owing to vibration and cause an accident.

- 5 Close the rear bumper cover.

Replacing tire

Vehicle parking

! Park your vehicle in firm and level ground without disturbing traffic or traffic hazard to yourself.

If on the public road, please turn on hazard warning light and position a warning triangle.

Ensure that the ground where the jack is located is firm enough to support the jack and the vehicle to be lifted; otherwise it will move for instability, causing damage to the vehicle and/or personal safety.

Secure other wheels with proper wheel stoppers.

Never use jack if the ground is sloping. If jack is unsuitable to use or you are unsure to complete the task safely, please ask for assistance.

Front wheels must be straight-ahead.

Turn off the vehicle power, activate the parking brake, and place the gear lever in P gear.

For models with air suspension, the air suspension maintenance mode must be enabled before lifting the vehicle. For the enable method, please see "Air suspension system" in the Starting and Driving section.

Emergency Troubleshooting

Positioning jack

! Only use jack at specified jacking points. The lifting height shall not be more than the height necessary for tire replacement (such as no more than 30cm above the ground).

Before using the jack, ensure all passengers have left the vehicle.

No person should place any portion of their body under a vehicle that is supported by a jack.

The jack shall be perpendicular to the vehicle body while lifting.

The front wheel jacking point is located on the second mount bracket of the frame behind the front wheel. The rear wheel jacking point is located on the lifting bracket in front of the rear wheel. When lifting the jack, it is necessary to insert the pin on the jack into the hole in the jacking surface of the frame.

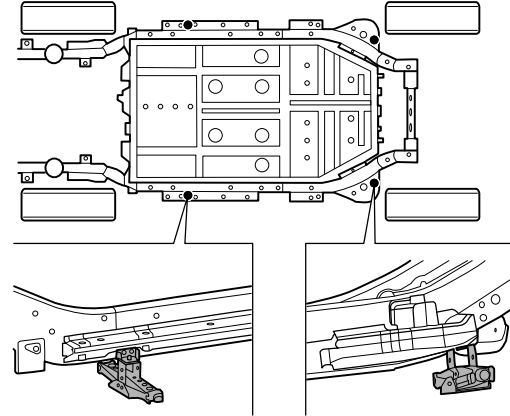

Replacing with spare tire

! During the lifting, do not start the vehicle. Never walk under the lifted vehicle.

Before removing the wheel nut, make sure the vehicle is stable and will not slide or move.

Torque wrench shall be used to check exact tightened torque of wheel nuts and tire pressure as soon as possible after replacing the wheel.

Replaced wheel, jack and vehicle tool kit must be stored in specified location. Otherwise they may cause damage or personal injury during impact or heavy braking if casually or improperly placed.

Emergency Troubleshooting

- 1 Remove the spare tire (See "Spare tire" in this section).
- 2 Check whether the jack is still perpendicular to the jacking points; Change position when necessary.
- 3 Use the wheel nut wrench in the vehicle tool kit to loosen the wheel nut counterclockwise.
- 4 Install the auxiliary rotating extension bar and turn the wheel nut wrench clockwise until the wheel to be replaced is just off the ground.

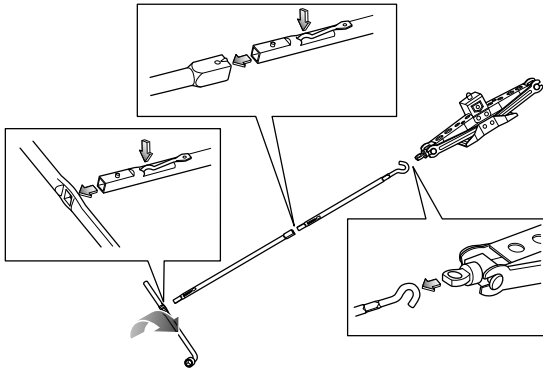

- 5 Remove the retaining nuts of the wheel and then carefully remove the wheel.
- 6 Replace it with the spare wheel and then tighten the wheel nuts clockwise.
- 7 Lower the vehicle body and remove the jack.

- 8 Fully tighten the retaining nuts of the wheel in a diagonal order (see the diagram); the wheel nut torque is $180\pm 18\text{N}\cdot\text{m}$.
- 9 Put away the replaced wheel, auxiliary rotary post of the jack, wheel nut wrench, jack and vehicle tool kit.
- 10 Mount the replaced wheel into the position of spare tire, see "Spare tire" in this section.

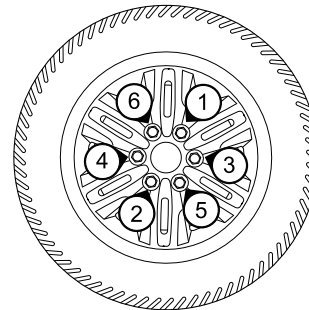

Caution

Be sure to fully lift and tighten the tray of the spare tire device even if no spare tire is mounted.

Emergency Troubleshooting

Towing a vehicle

While being towed, relative national regulations about vehicle towing shall be abided by.

Towing hitch

Front towing hitch

The front towing hitch is located at the lower right side of front bumper.

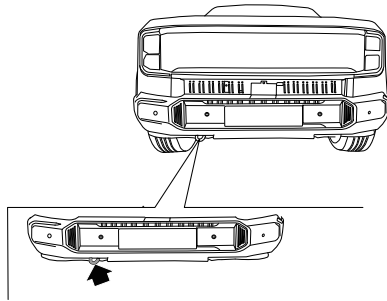

Note: For vehicles configured with the front towing hitch cover, when towing the vehicle, it is required to remove the towing hitch cover. First press the upper end of the cover inward, and rotate it to pull out the towing hitch cover. After removal, please note that the towing hitch cover shall be

placed in the vehicle in case of loss, and reinstall the towing hitch cover after vehicle towing is completed.

Caution

The mass that the front towing eye can bear is 1/2GVW (total mass). Do not tow the vehicle with a mass more than this value.

The application range of towing rope is as shown below:

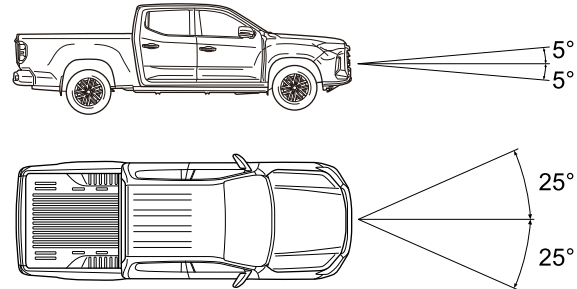

Emergency Troubleshooting

Towing

Before towed

 **To ensure the steering gear can rotate freely, be sure to power on the vehicle and keep it powered on during towing process. This is to ensure the steering is unlocked, and the turn signal lamps and brake lamps can operate.**

Being towed

When the vehicle is being towed, release the parking brake and engage N gear. For models with air suspension, the rolling surfaces of the wheels must be tied and fixed when transporting the vehicle on a flatbed truck. Otherwise, the pressure change of the air suspension during transportation may cause the vehicle to move, resulting in serious accidents or property loss.

 **There is no brake booster assist or power steering assist when the motor is not running. In this case, it requires greater effort to operate the brake pedal, and longer time and greater effort to rotate the steering wheel.**

Caution

- When towing, for 2WD models, be sure to lift the driving wheels off the ground, and maintain the towing speed less than 50km/h. When the towing distance is less than 50km, place the shift lever in N gear.
- When towing, for 4WD models, all four wheels must be off the ground, please use a flatbed truck for transportation.

 **After a severe collision, if you find it impossible to move the shift lever into N, shift from P to another gear, or turn the steering wheel, please note that the drive wheels must not be on the ground when towing. Failure to do so may lead to severe damage to the transmission and high service costs. It is recommended to tow the vehicle with a flatbed trailer. When towing, all four wheels must be off the ground.**

 **When the vehicle is pulled onto the flatbed trailer, it is prohibited to have any person or object behind the trailer, as this may lead to personal injury or death. When towing the vehicle with the front wheels lifted or on a flatbed trailer, passengers are not allowed to stay in the vehicle, otherwise an accident may occur and lead to personal injury or death.**

Emergency Troubleshooting

Jump start

Battery disconnection

! Always wear protective gloves and eye protecting glasses when working on a battery. Do not use naked light, cause sparks or smoke in the area of the battery. You can be seriously injured and the vehicle damaged.

To disconnect battery, disconnect negative (-) earth terminal first and then positive (+). To connect battery, install and secure positive cable (+) first and then negative (-) cable. Smear the terminals with petroleum jelly.

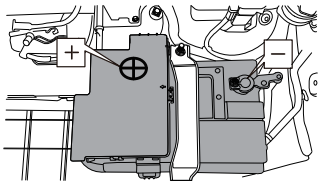

Caution

Before disconnecting the battery, always shut down the motor and all electrical devices for more than 2 minutes. While disconnecting, never allow the terminal to contact with the metal parts of vehicle body. Otherwise short circuit may cause electric spark. Electrical system will be damaged if positive and negative cables are connected reversely.

Jump start

! Never pull or tow the vehicle to start.
! Ensure the rated voltage of two batteries is the same (12V) and the jumper cable is acknowledged as the cable used for 12V vehicle battery.

Jumper

- Pull two vehicles together as possible.
- Shut down the motor and all electric equipment.
- Connect the positive terminals (+) of two batteries with red jumper cable.
- Connect black jumper cable from power supplying battery negative terminal (-) to earth point (not negative terminal) of the battery-powered vehicle that needs to be powered.
- Ensure all connection mechanisms are well connected.
- Check that the jumper cable clear of any moving parts when the motor starting.
- Check that the handbrakes of the two vehicles are applied and gear lever is in P position.

Emergency Troubleshooting

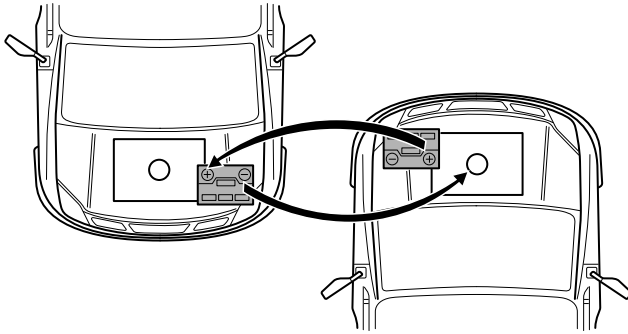

likely to need repairing. Please contact our Service Dealer for repair.

Disconnecting

- Shut down the engine or motor of the vehicle.
- Ensure the cable terminals shall not contact with each other.
- Remove the jumper cable. Removal is the reverse of connection.

Starting

Start the battery-powered vehicle to be powered and allow it to idle for several minutes.

- Start the vehicle whose battery needs to be powered.
- Allow the vehicle to idle for more than 2 minutes after started.

Note: *If it fails to start after several attempts, the vehicle may need maintenance.*

Note: *If the malfunction indicator lamp appears on the instrument cluster after starting up the vehicle, it may be due to low battery voltage. Please try to power off and power on the vehicle after the battery voltage is stable (the vehicle can be started on its own without jump start). If the malfunction indicator lamp on the vehicle's instrument cluster remains on after several attempts, the vehicle is*

Emergency Troubleshooting

Fuse replacement

Fuses of this vehicle are located in three boxes.

Caution

Spillage of liquid to any electric components in the vehicle may damage the components, so it is required to cover any electric components. The content of the fuse specification list will be constantly updated according to the vehicle configuration and technical status, please see actual state of your vehicle. The corresponding components are provided only when the actual vehicle is configured with the functions. Otherwise, the components are not provided.

Driver compartment fuse box

Driver compartment fuse box is located behind the lower storage box at driver side.

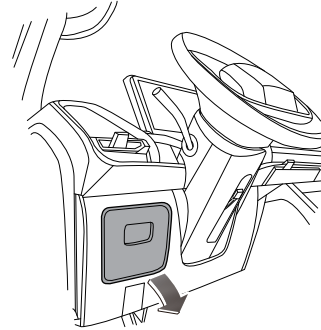

Emergency Troubleshooting

Fuses in the driver compartment fuse box can be identified by the label on the back of lower storage box cover at driver side.

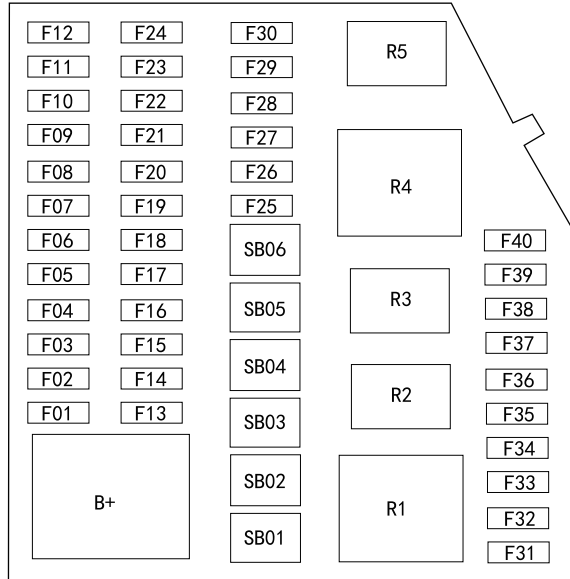

Specification

Code	Specification	Function
F01	5A	Right combination switch/electronic shift lever
F02	5A	ETC/FVCM

Code	Specification	Function
F03	15A	Steering wheel heating
F04	5A	TBOX
F05	5A	GW/ICGM
F06	5A	FICM (Front Infotainment Control Module)
F07	5A	2nd row seat heating
F08	5A	ACU (Airbag Control Unit)
F09	5A	Automatic anti-dazzle rearview mirror / streaming media rearview mirror
F10	/	Reserved
F11	5A	Front USB charging port
F12	20A	12V power socket
F13	5A	ETC/rain/solar sensor/FVCM
F14	5A	Alcolock
F15	25A	FICM (Front Infotainment Control Module)
F16	30A	Towing hook
F17	20A	Openable rear quarter lock
F18	7.5A	GW/ICGM
F19	5A	IPK (Instrument Pack)
F20	7.5A	Entertainment screen /front passenger screen
F21	10A	OBD
F22	5A	TBOX

Emergency Troubleshooting

Code	Specification	Function
F23	/	Reserved
F24	5A	Electronic shift lever
F25	10A	ACU (Airbag Control Unit)
F26	30A	ZCU_DR(KL30_10)
F27	30A	ZCU_DR(KL30_6)
F28	30A	ZCU_PR(KL30_6)
F29	30A	ZCU_DR(KL30_7)
F30	30A	ZCU PR(KL30_3)
F31	5A	Instrument panel ambient lamp
F32	5A	Sun visor vanity lamp
F33	5A	Clock spring
F34	5A	Central control switch/auxiliary fascia console switch
F35	5A	USB HUB
F36	5A	DMS(Driver Monitoring System)
F37	5A	Mobile phone wireless charging
F38	/	Reserved
F39	15A	2nd row 60% seat heater
F40	15A	2nd row 40% seat heater
SB01	40A	Front blower
SB02	40A	ZCU_PR(KL30_9)

Code	Specification	Function
SB03	40A	Rear defrost
SB04	30A	Panoramic sunroof
SB05	40A	ZCU_DR(KL30_9)
SB06	30A	2nd row seat heating
R1	40A	Front blower relay
R2	35A	Openable rear quarter lock relay
R3	35A	2nd row 60% seat heater relay
R4	40A	Rear defrost relay
R5	35A	2nd row 40% seat heater relay

Emergency Troubleshooting

Front compartment fuse box

Front compartment fuse box is located at the right of compartment wall at the front hood bottom (viewed from the front of vehicle). Fuse can be accessed by just removing the cover of front compartment fuse box.

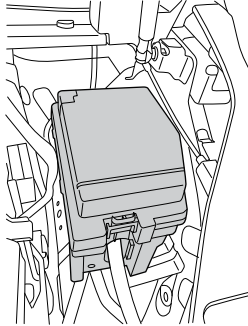

Caution

Before opening the fuse box cover, make sure its surroundings are dry and no fluid flows from any direction into the opened fuse box, otherwise the fuse box will be damaged, leading to serious consequences.

Fuses in the front compartment fuse box can be identified by the label printed at the back of the fuse box cover.

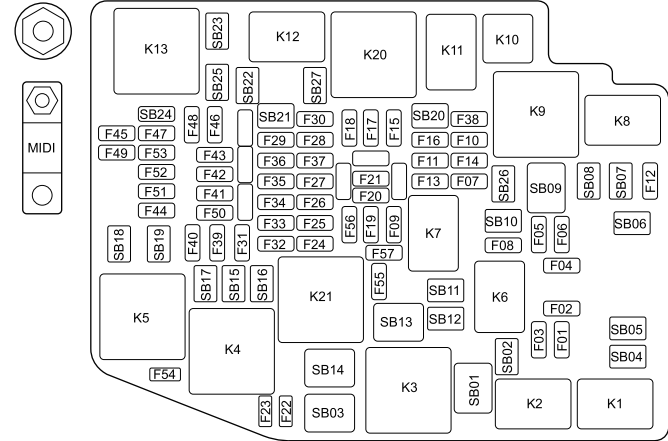

3

Specification

Code	Specification	Function
F01	20A	Fuel pump motor controller
F02	10A	EVCC/electric compressor /three way proportional water valve/multi way proportional water valve/WPTC auxiliary heating
F03	3A	UEC(Front compartment fuse box) ground 3
F04	5A	Driver seat massage

Emergency Troubleshooting

Code	Specification	Function
F05	20A	Horn
F06	/	Reserved
F07	/	Reserved
F08	10A	Cooling fan/coolant level sensor
F09	/	Reserved
F10	7.5A	KL87 power supply
F11	/	Reserved
F12	/	Reserved
F13	/	Reserved
F14	/	Reserved
F15	/	Reserved
F16	25A	Electric drive water pump
F17	15A	Battery water pump
F18	15A	Air conditioning compressor
F19	10A	IMCU KL30_2
F20	7.5A	BMS(Battery Management System)
F21	10A	IMCU KL30
F22	20A	ZCU_PR(KL30_2)
F23	30A	ZCU_DR(KL30_3)
F24	25A	IEC(Driver compartment fuse box) KL15
F25	5A	Wading radar sensor

Code	Specification	Function
F26	5A	IMCU/SAC
F27	5A	AVAS
F28	5A	Remote control parking/towing assist controller
F29	5A	EPS(Electric Power Steering)
F30	10A	ADAS Front windshield heating
F31	20A	Rear motor_parking motor
F32	10A	Driver seat ventilation
F33	5A	ESP/EBOOST
F34	5A	Headlamp regulating motor
F35	5A	ZCU IG signal
F36	5A	PDC radar
F37	5A	BMS/electronic steering column lock
F38	/	Reserved
F39	20A	ZCU_DR&PR(KL30_1)
F40	20A	Battery charger CCU
F41	10A	Remote control parking/towing assist controller
F42	10A	Front motor controller/electronic steering column lock
F43	5A	Millimeter wave radar
F44	5A	ZCU KL30S signal

Emergency Troubleshooting

Code	Specification	Function
F45	5A	Four door ambient lamp
F46	/	Reserved
F47	20A	IEC(Driver compartment fuse box) ACC
F48	10A	2nd row USB charging port
F49	/	Reserved
F50	/	Reserved
F51	5A	ZCU ACC signal
F52	/	Reserved
F53	/	Reserved
F54	30A	Driver power seat 2
F55	/	Reserved
F56	20A	ZCU_DR(KL30_2)
F57	30A	ZCU_PR(KL30_8)
MIDI01	150A	IEC(Driver compartment fuse box) main power
SB01	/	Reserved
SB02	30A	Front wiper
SB03	/	Reserved
SB04	/	Reserved
SB05	30A	Electric roller shutter cover
SB06	30A	Rear panel power window

Code	Specification	Function
SB07	/	Reserved
SB08	30A	Driver power seat 1
SB09	40A	ZCU_DR(KL30_5&KL30_8)
SB10	/	Reserved
SB11	/	Reserved
SB12	/	Reserved
SB13	60A	Ebooster(electronic vacuum booster)
SB14	60A	ESC motor
SB15	30A	ZCU_PR(KL30_5)
SB16	30A	Towing hook
SB17	30A	ZCU_DR(KL30_4)
SB18	25A	IEC(Driver compartment fuse box)KL30S
SB19	30A	Front passenger power seat
SB20	20A	Heater water pump
SB21	30A	ZCU_PR(KL30_10)
SB22	/	Reserved
SB23	30A	ZCU_PR(KL30_7)
SB24	40A	ESC solenoid valve
SB25	/	Reserved
SB26	30A	ZCU_DR(KL30_11)
SB27	40A	Air suspension compressor

Emergency Troubleshooting

Code	Specification	Function
K1	35A	Front wiper HS/LS relay
K2	35A	Front wiper ON relay
K3	/	Reserved
K4	70A	IG relay
K5	40A	Economizer relay
K6	/	Reserved
K7	/	Reserved
K8	/	Reserved
K9	70A	Main relay
K10	20A	Air conditioning compressor relay
K11	35A	Heater water pump relay
K12	/	Reserved
K13	70A	ACC relay
K14	/	Reserved
K15	/	Reserved
K16	20A	Horn relay
K17	20A	Electronic auxiliary water pump relay
K18	20A	ADAS Front windshield heating relay
K19	/	Reserved
K20	40A	Air suspension compressor relay
K21	/	Reserved

Battery fuse box

The battery fuse box is located on the battery positive terminal.

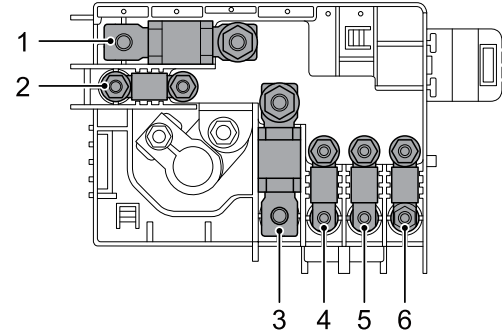
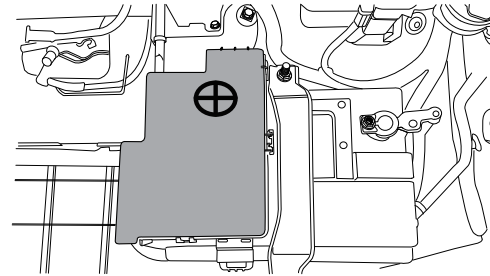

Emergency Troubleshooting

Specification

Code	Specification	Function
1	250A	UEC(Front compartment fuse box)
2	/	Reserved
3	250A	DCDC(DC-DC voltage converter)
4	80A	Cooling fan
5	100A	EPS(Electric Power Steering)
6	/	Reserved

Fuse replacement

! Only replace with fuses of the same specifications/rated current. Installing nonspecific fuse will damage electrical system and even cause fire. Before attempting to replace the fuse, the vehicle power and all electrical devices must be turned off. Any unauthorized change to vehicle electrical system will cause serious adverse effect and fire on the electronic management system.

Pull the fuse outward with puller provided in fuse box to remove the fuse. Internal wiring of the fuse can be used to identify blown fuse (arrowed).

3

Note: Repeated failure with the same fuse is the indication of circuit failure. Please contact Our Service Dealer as soon as possible.

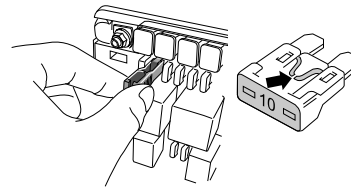

Caution

Unauthorized change to electrical system of the vehicle will invalidate the warranty.

Emergency Troubleshooting

Bulb replacement

Before replacing any bulb, turn off the ignition switch and the lamp switch, to avoid any possible short circuit.

When removing or installing the bulb, do not touch the bulb with hands. If touched, wipe away the hand print with a piece of cloth or alcohol.

Caution

The type and specification of replaced bulb must be the same as that of the original bulb.

Lamp Specification

Lamp	Specification
License plate lamp	W5W

Bulb replacement

The followings are the methods for removing the bulb; for other unlisted bulbs that need to be replaced, please contact our service dealer for repair. The bulb installation is the reverse of removal, which will not be described below.

License plate lamp

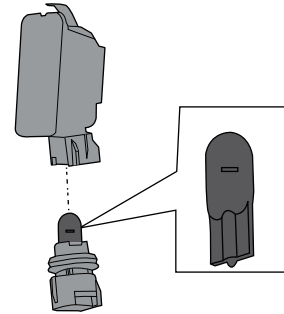

- 1 Rotate the license plate lamp bulb cover counterclockwise and remove it.
- 2 Remove the license plate lamp bulb.

Maintenance and Service

232 Regular maintenance

232 Owner's check

233 Front compartment hood

237 Front compartment

238 Coolant

239 Brake fluid

240 Washer fluid

241 Wiper blades

243 Seat belts

244 Battery

247 High voltage battery pack

249 Tires

251 Other maintenance

Maintenance and Service

Regular maintenance

Regular maintenance is the key to economy, safety and reliability for your vehicle and it must be remembered that the responsibility for maintaining your vehicle in a safe, roadworthy condition rests ultimately on you, the owner/operator.

Necessary maintenance and the intervals have been specified to maintain your vehicle properly. Regular vehicle maintenance shall be done by Our Service Dealer in accordance with Warranty & Service Handbook.

It is in your best interest to have your vehicle regularly maintained in accordance with regulations.

Our Service Dealers are recommended as they have qualified personnel, required facilities and can offer the unique pre-planned service which will give maximum vehicle reliability.

Owner's check

The following are a few simple but important checks which you shall make at regular intervals before driving to ensure reliable and economic operation:

Daily checks

- The lighting (make sure all lens are clean), horn, instrument cluster, warning lights and indicators, wipers and washers are functioning.
- The seat belts are intact.
- The brakes operates normally.
- Visually check for signs of water, fluids, exhaust and other leaks under the vehicle.

Weekly checks or check before a long journey

- Check fluid level/refill.
 - Coolant
 - Windshield washer fluid
 - Brake fluid
- Check for condition and pressure of all tires (including the spare tire).
- Check and operate A/C system.

Harsh conditions

For vehicles often used in harsh conditions, it is recommended to shorten the maintenance interval.

Regular vehicle maintenance shall be done by Our Service Dealer in accordance with Warranty & Service Handbook.

Front compartment hood

Open front compartment hood

Note: The electric front compartment hood swings upward to open. When opening/closing the front compartment hood, make sure that there are no objects or people near the front of the vehicle. Ensure that the front compartment hood is closed before driving. Driving the vehicle without closing the front compartment hood may block the vision of the driver and bring the risk of damage to the parts.

Note: Before opening the electric front compartment hood, it is required to check for any heavy objects on the surface, and remove it timely if any. If heavy objects are not removed, the electric front compartment hood may fail to open electrically due to excessive weight.

There are multiple electric opening and closing methods of the electric front compartment hood. For safety reasons, the front compartment hood can be opened only when the vehicle is powered on and engaged in P gear.

Electric front compartment hood switch in the front of the vehicle

After the vehicle is unlocked, short pressing the electric front compartment hood switch can open the front compartment hood. When the vehicle is locked, carrying PEPS remote key to approach the front compartment hood and short pressing the electric front compartment hood switch can also open the

Maintenance and Service



front compartment hood. When the front compartment hood is moving, short pressing the electric front compartment hood switch will pause the front compartment hood's motion, and short pressing the switch again will cause the front compartment hood to move reversely.

After unlocking the vehicle, short press the front compartment hood electric switch to unlock the front compartment hood, and the front compartment hood will automatically open.

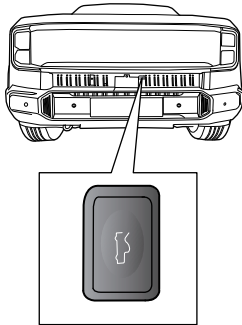
When the vehicle is in the locked state, carrying the PEPS remote control key close to the front compartment, short pressing the front compartment hood electric switch can also unlock the front compartment hood. After unlocking, the front compartment hood will automatically open.



Front compartment hood unlock and lock button on the remote key with PEPS

Long press the button  to open and close the front compartment hood. During opening and closing, short press the button  to stop the front compartment hood movement, and long press the button  again to reverse the front compartment hood movement.

Electric front compartment hood touch button on the central control screen

The electric mode and manual mode of the front compartment hood can be selected on the central control screen. In the manual mode, the front compartment hood can only be unlocked, but cannot lift up automatically; in the electric mode, the next opening height can be set by the opening preset, and the front compartment hood can be controlled by the “Open”, “Pause” and “Close” buttons on the central control screen.

Close front compartment hood

After closing the front compartment hood, check if it is completely locked by trying to lift its front edge. If the front compartment hood is not completely locked, please open it again and repeat the closing action.

Caution

Before closing, check that there is no tools, rags, equipment, etc. left in the area under the front compartment hood.



Before closing, please check for living objects, such as pets, in the storage box area, and do not close the box if any (critical).

Note: *Open the front compartment hood after the vehicle is locked. If you leave the remote key with PEPS inside the front compartment by mistake, and close the front compartment hood, the hazard warning lamp of the vehicle will flash, and the front compartment hood will automatically open. In this case, you need to take out the remote key with PEPS before closing the front compartment hood again.*

Front compartment hood unclosed alarm

If the front compartment hood has not been locked completely, the corresponding alarm icon will be displayed on the screen. If the front compartment hood is found not locked completely

when the vehicle is running, then warning tones will be sounded together.

Caution

- For safety reasons, the front compartment hood must be closed tightly before driving. Therefore, it is required to check if the latch has been inserted into the lock after closing the front compartment hood, that is, to check if the front compartment hood is aligned with the body parts.
- During driving, if the front compartment hood is found not closed completely, please pull over in a safe condition, and get off to close the front compartment hood before resuming the driving.
- Mind your hand when closing the front compartment hood.
- Prohibit standing and stacking heavy objects on the front compartment hood.

Note: *The electric front compartment hood cannot be open and closed for 10 cycles in a row, otherwise thermal protection may be activated. If your car has activated thermal protection for front compartment hood, be sure not to operate the front compartment hood, and wait for 1 minute for the thermal protection to exit before your another operation. If the front compartment hood encounters an obstacle during the electric opening or closing cycle, it will automatically move reversely to avoid the obstacle. After removing the obstacle, you can operate the electric front compartment hood again. If the front compartment*

Maintenance and Service

hood encounters an obstacle 3 times in a row during electric closing or opening, the electric function will be disabled. After removing the obstacle, closing the front compartment hood manually can restore the normal electric function. Electric follow-up strategy: When the electric front compartment hood is half open, it will automatically close or open to a set height under external force. Do not open or close the front compartment hood manually with force during the electric operating cycle. When the front compartment hood is close, it will not be open if the battery is disconnected or the voltage is too low; when the battery is reconnected or charged, the front compartment hood will restore operation. When the front compartment hood is open, it will lose electric function if the battery is disconnected or the voltage is too low, and needs to be closed manually; when the battery is reconnected or charged, the front compartment hood will restore electric function.

Caution

To close the front compartment hood manually, first slowly lower the front compartment hood to about 20 ~ 30cm away from its locked position, then apply some downward force with both hands by pressing down on the position of the front compartment hood marking in the figure below, so as to close it to the fully locked position.

Caution

When the electric front compartment hood is working, make sure that no people is in its opening and closing path, otherwise you or others may be hurt.

Front compartment hood emergency opening

When the vehicle is powered off or unable to unlock the compartment hood electronically, the front compartment hood can be manually unlocked.

Pull the emergency unlocking handle of the front compartment hood located below the driver's side dashboard upwards twice as shown in the diagram to unlock the front compartment hood, then lift the front compartment hood.

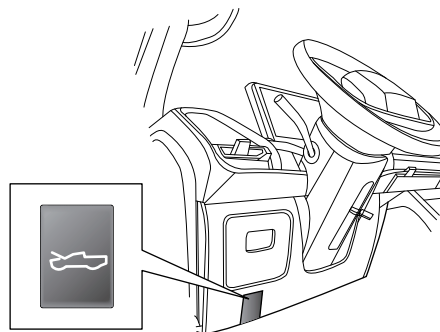

Caution

If the front compartment hood cannot be opened in an emergency by pulling its opening handle twice, the following methods can be adopted:

- Pull the front compartment hood emergency unlock handle again twice in succession.
- One person pulls and holds the front compartment hood emergency unlock handle to the maximum position while the other person walks to the front compartment hood and manually lifts its front end.
- If the front compartment hood still cannot be opened in an emergency with the above methods, it is recommended that you have it serviced at Our Service Dealer.

When manual closing of the front compartment hood is required, hold the front compartment hood with both hands and then lower it. When the front compartment hood is lowered about 20-30 cm away from its locking position, apply a certain downward force to close it with certain acceleration.

Front compartment

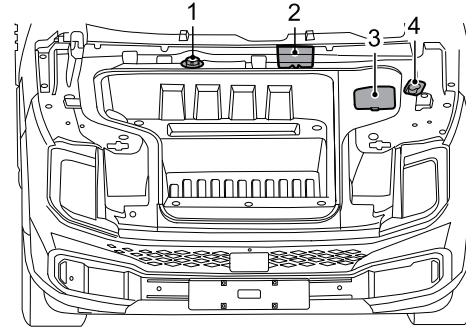

- 1 Coolant reservoir
- 2 Brake fluid reservoir maintenance cover plate
- 3 Battery maintenance cover plate
- 4 Washer fluid reservoir

Maintenance and Service

Coolant

 **Coolant is harmful if swallowed. Do not allow coolant to contact the eyes or skin. If it does, rinse immediately with plenty of water.**

Please add correct specification coolant. Never driving the vehicle if coolant of correct specification is not filled. Coolant specification see "Recommended fluid oil".

At specified intervals the cooling system shall be drained, flushed and refilled with the correct amount of coolant.

Caution

When refilling or replacing coolant, only the specified coolant can be used. The use of non-recommended coolant could cause damage to the cooling system and may invalidate the warranty.

Check and refill

 **Do not remove the expansion tank cap while the cooling system is hot, for overflowed water vapor or hot coolant may cause personal injury. If coolant has to be charged when the system is hot, wait for 10 minutes, place a thick cloth over the filler cap and turn the cap slowly anti-clockwise to release the pressure in the expansion tank before removing the cap.**

Always check the coolant level with the vehicle on level ground and the coolant system stationary (cold condition).

The level is visible in coolant expansion tank and normal level shall be between "MAX" and "MIN" marks.

If the level drops to "MIN" mark, clean area around the coolant expansion tank cap and then turn anti-clockwise to remove it. Top-up with the specified fluid between "MAX" and "MIN" marks. Install the expansion tank cap.

Note: The coolant may expand when it becomes hot, so the liquid level may be higher than the level mark.

Caution

If the level has fallen appreciably, or topping-up is required frequently, suspect leakage or overheating and contact Our Service Dealer for inspection.

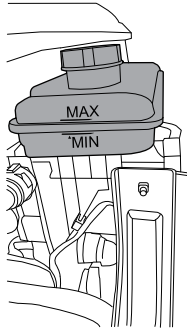

Precautions for cold weather

In order to reduce possible problems which may occur in cold weather, please consider the following suggestions:

- Since the standard freezing point of the coolant used in the vehicle is -35°C (with the mixture ratio of coolant stock solution and water of 1:1), it is necessary to park the vehicle in areas where the coolant temperature can be maintained above -35°C .
- If you are using your vehicle in extremely cold areas where the ambient temperature is below -35°C , please use the coolant of appropriate proportion based on the local temperature. (Refractometer T10007 can be used to detect the freezing point of the coolant)

Brake fluid

! If there is a significant drop in the level of the brake fluid, contact Our Service Dealer for service as soon as possible.

Use only new brake fluid of the specified type. Use of brake fluid which is old or not the specified type can cause loss of braking performance.

Brake fluid cleanliness is essential. Any dirt entering the system can cause loss of braking performance.

Do not allow brake fluid to contact your skin or eyes; If it does, rinse immediately with plenty of water. Keep brake fluid out of the reach of children.

Caution

- Only refill the brake master cylinder with brake fluid complying with specification DOT4. Do not use brake fluid of any other type.
- Brake fluid will damage the paintwork when coming in contact with it. Wipe it clean immediately and rinse with water.

Maintenance and Service

Check and refill

Be sure to check the brake fluid level after the vehicle is parked on a flat ground and the brake system is in cold state. Brake fluid level is visible on the reservoir and the normal level shall be between "MAX" and "MIN" marks. If the level drops to "MIN" mark, clean area around the filler cap and then turn anti-clockwise to remove it. Fill up specified new brake fluid between "MAX" and "MIN" marks and install the reservoir cap.

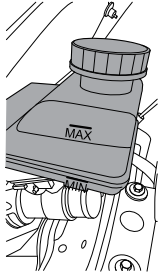

If the level falls below "MIN" mark, "brake system warning light (red)" on information cluster will light on. This indicates fault in the braking system which must be investigated immediately. If in driving, IMMEDIATELY bring the vehicle carefully to a halt. Contact Our Service Dealer for service as soon as possible. Do NOT continue driving.



Never discard used brake fluid casually to avoid the environment pollution.

Washer fluid

Check and refill



Driving with a non-operational washer system can be dangerous; always check it before driving. When refilling the washer fluid, do not let it splash onto the paint surface of body. If the washer fluid splashes onto hands or other parts of human body, immediately wash it clean with clear water.

Washer fluid is used to clean the windshield. Check the level of the water fluid on a weekly basis. When the level is too low, please refill the washer fluid. To refill the washer fluid, please open the front compartment hood, open the washer fluid reservoir lid, and then close the lid tightly after refill. For washer fluid specification please see "Recommended fluid oil" in General Technical Parameters section.

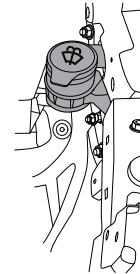

Caution

- Do not use antifreeze or vinegar/aqueous solution in reservoir - Antifreeze can damage paint surfaces and vinegar can damage washer pump. Use the washer fluid recommended and approved by our company. The improper use of washer fluid in winter may cause freezing and damage the washer pump.
- Turning on the washer switch without washer fluid will damage the washer pump.
- When the windshield is dry without washer fluid, turning on the wiper will damage the windshield and the wiper blades. Please spray the washer fluid and turn on the wiper when the washer fluid is sufficient.
- It is prohibited to use windshield cleaning solutions with an ethanol content exceeding 10%. In high-temperature environments, this type of windshield cleaning solution can cause corrosion to the rear lighting fixtures, leading to cracking of the rear lighting fixtures.

Washer nozzle

Check if the washer nozzle is clean and the direction is correct with the washer regularly. If the nozzle is blocked, insert a needle or thin wire into the hole to clear the blockage.

Wiper blades

Inspection

Inspect the edge of the blade for roughness or damage, and check that the blade rubber is secure throughout its length.

Note: Traces of grease and other impurities on the rubber can prevent the wipers from working correctly, and can also damage the windshield glass.

Maintenance and Service

Replacement of windshield wiper blade

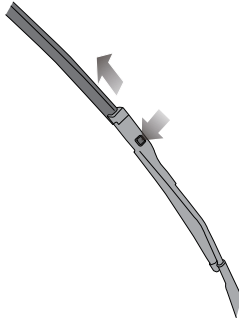

Before the replacement of windshield wiper blade, the front wiper switch needs to be adjusted to the Service position.

Within 10 seconds after the vehicle is powered off, toggle the front wiper switch from OFF to high speed HI, and then back to OFF, so that the front wiper blades are moved to the highest point (Service position), and then lift the wiper arm from the windshield, so that the blade is at about 15° to the wiper arm, and then replace the blade as follows:

Removal

- 1 Press the button on the wiper arm, and pull the upper end of the blade outward to disengage it from the wiper arm.
- 2 Remove the blade from the wiper arm, and discard it.

Installation

- 1 Put the fitting of the new wiper blade into the slot of the wiper arm.
- 2 Push the blade towards the arm until the wiper blade is fully engaged. Ensure the wiper blade is properly secured on the arm.
- 3 Place the wiper assembly back to the windshield.

Caution

Within an ignition cycle (vehicle powered off→vehicle powered on or start→vehicle powered off is a ignition cycle), the front wiper service function can be used only once.

Maintenance

Wash with high-quality cleaner or neutral detergent and wipe it clean with a dry, soft cloth that is free of lint.

Seat belts

Inspection



The belts also have a sensitive retractor which is designed to lock only during heavy acceleration, deceleration or sharp turns.

Do not test the locking device by deliberately jerking forward your upper body.

Check ALL seat belts as follows:

- Check all belt anchorage points for safety.
- Insert the locking tab into the buckle, and check whether the locking operation is clear. Push the red button and check if the locking tab pops neatly.
- With the seat belt half loosened, hold the locking tab and abruptly pull it. Check if the safety mechanism can be locked automatically and prevent further looseness.

Maintenance and service



Do not attempt to repair the retractor or buckle mechanisms, or to modify the seat belts in any way. Seat belts subjected to strain as a result of an accident shall be replaced, and the anchorage points checked, by Our Service Dealer.

Regularly inspect the belt webbing for signs of abrasion or wear, paying particular attention to the anchorage points and adjusters.

Clean the seat belt with a sponge dipped with warm water and mild soap; it can be naturally dried, and must not be dried by direct heating or exposure under sunlight. Do not allow water to penetrate into the retractor. Never bleach or dye a seat belt as its strength may be reduced.

Battery

Warnings and instructions for battery:



Wear goggles!



The battery acid is strongly corrosive. Ensure to wear protective gloves and goggles!



Open fires, electric sparks, strong lights and smoking are strictly prohibited!



Explosive gas mixture may be generated during battery recharging!



Ensure to keep any child away from the acid and the battery!



There may be risks of injury, corrosion, accident and fire during operations on the battery and any electrical appliance in the vehicle!

Ensure to wear goggles. Do not allow acid or leaded particles to get into your eyes or onto your skin or clothes.

The acid in the battery is highly corrosive. Ensure to wear protective gloves and goggles. The battery cannot be turned over, or acid may flow out of the vent. If acid gets into your eyes, immediately rinse with clean water for a few minutes, then see a doctor



immediately. If acid splashes onto your skin or clothes, immediately neutralize it with thick soap solution, and then rinse with plenty of water. If you drink acid by mistake, see a doctor immediately.

Open fires, electric sparks, strong lights and smoking are prohibited. When working on cables and electrical appliances and removing electrostatic loads, avoid the generation of electrical sparks. The electrodes of battery can **NEVER** be short-circuited, or it may cause personal injury due to large energy sparks.

Explosive gas mixture may be generated during battery recharging. The gas vent of battery should be kept unblocked to discharge the gas correctly. During recharging, the battery should be located in a space with good ventilation.

Ensure to keep any child away from the acid and the battery.

Turn off the motor, vehicle power supply and all electrical appliances before working on electrical appliances. Remove the negative cable of battery. When replacing bulbs, only the lights are required to be turned off.

Pay attention to the polarities of power supply. Before powering on, the matches of polarities must be checked.



The duration of each powering on should not be less than 5 seconds. Try to avoid powering on and off too frequently.

When removing the battery, please remove the negative cable before positive cable.

Before powering on the battery again, all electric appliances should be turned off. First connect the positive cable, then the negative one. Never connect the cables incorrectly - risk of fire!

Unauthorized removal and installation of battery is strictly prohibited since such operation may cause severe damage to the battery and fuse box in some cases. Please contact Our Service Dealer.

Do not disconnect the battery when the vehicle is powered on or the motor is running, otherwise it may damage the electrical appliances (electrical components).

To prevent the battery housing from exposing to ultraviolet ray, do not expose the battery under the sunshine.

Duration of storing the vehicle

If the vehicle is to be parked for an extended period of time, the static current electrical appliance (like clock, security devices) will drain the battery, and the battery has to be charged. To avoid

such case, charge the battery or disconnect the battery negative cable during the vehicle parking.

Note: Please pay attention to the warnings & instructions for battery before working on it.

Caution

Ensure to turn off the vehicle power supply during parking, otherwise the parking time can be reduced significantly.

Operating in winter

There are particularly strict requirements on the vehicle battery operation in winter. In addition, the starting power provided by the battery at low temperature is only a part of that at normal temperature. Therefore, we recommend to have the vehicle battery checked by Our Service Dealer before the cold season begins, and recharge it if necessary.

If the vehicle is not used for weeks in cold season, please remove the vehicle battery and store in an ice-free room, to prevent it from freezing and damage.

Charging the battery with ground equipment



Do not charge any frozen battery, there is a risk of explosion! Even if the battery has been unfrozen, there may be battery acid spilling out and cause corrosion. Any frozen battery must be replaced.

Maintenance and Service

Turn off the vehicle power supply and all electrical appliances before charging. If the vehicle has been parked for a long period and cannot be started due to lack of power (general terminal voltage \leq 12V), the battery must be removed from the vehicle and charged with a ground equipment (follow the instructions provided by the manufacturer of the charging equipment).

During charging with small current (e.g., a small charging equipment), it is unnecessary to remove the connecting cables of battery. However, please ensure to read the instructions from the manufacturer of the charging equipment.

Before fast charging (i.e., large current charging), both of the connecting cables must be removed.

Note: Please pay attention to the warnings & instructions for battery before working on it. During the charging, the charging equipment can only be powered on after the electrode clamps of charging equipment is connected to the electrodes of battery as required. After the charging is finished, turn off the charging equipment first, remove the power cable, and then remove the electrode clamps of charging equipment from the battery. When charging the external device, the electrodes must be connected accordingly. Do not connect the positive electrode of the battery to the negative electrode of the charging device, and do not connect the electrodes in reverse.

Caution

- Keep any child away from the battery, battery acid and charging equipment.
- The battery can only be charged in a space with good ventilation. Smoking is prohibited, and keep away from open fires and electric sparks, as explosive gas mixture may be generated when the battery is charged.
- Protect your eyes and face, never be too close to the battery. If acid splashes onto your eyes or skin, immediately rinse with clean water for several minutes before seeing the doctor.
- The fast charging of the battery is dangerous, which should be done by Our Service Dealer, because it requires professional charging equipment and knowledge.
- Any frozen or unfrozen battery must be replaced. Because cracks may be found on the frozen battery housing. It may cause leak of battery acid and damage to the vehicle.

Removing the battery

Turn off the vehicle power supply and all electrical appliances before the battery removal. To remove the battery, firstly remove the negative cable and then the positive cable. And then remove the bolt on the mounting bracket of battery to remove the battery.

Replacing the battery

The battery installed on your vehicle is designed for the corresponding mounting location. To replace the battery, please

ensure to use one with the same voltage (12V), structure and safety label. The current strength and capacity should be same with the original battery. Our Service Dealer can offer you with genuine batteries.

When installing the battery, please ensure that the vehicle power supply is turned off and all electric appliances are turned off.



Concerning the disposal of used battery, it is suggested to have the battery replaced by Our Service Dealer. Additionally, the battery can never be treated as household garbage because it contains sulfuric acid and lead.

Installing the battery

Before installing the battery, turn off the vehicle power supply and all electrical appliances. Put the battery in the installation position prepared for it, and fix it with the battery bracket. When connecting the battery, please fix the positive cable before the negative cable.

Caution

To prevent the battery from discharging, please turn off the vehicle power supply when you leave the vehicle.

High voltage battery pack

Instructions and restricted conditions



According to the characteristics of the lithium battery, the vehicle must be charged and discharged every 30 days in storage period(not limited to fast or slow charging), a long time parking easily results in damage of battery, thereby affects the running of whole vehicle. Failure to do so may result in loss or damage of the power battery, which may affect your enjoyment of the free warranty!

Pure electric vehicle is different from the conventional vehicle, therefore it has particularity on aspects of operation, storage and maintenance, and now some cautions are informed to you.

1 The vehicle cannot be parked for over eight hours in a place where temperature is over 60°C. Vehicle cannot be parked for over 20 hours in a place where temperature is lower than -30°C. Vehicle shall not be parked for more than 7 days in a place where temperature is above 45°C. If it exceeds maximum limit of the storage environment of vehicle, it will directly affect performance of vehicle and lifetime of high voltage battery pack.

Vehicle cannot be parked in high-temperature places.

2 To better extend the service life of high-voltage battery pack, it is recommended adopting slow charging. Fast charging is mainly used for emergency and long-distance driving.

Maintenance and Service

- 3 When using the vehicle, it is recommended to avoid frequent hard acceleration and deceleration, and choose flat and dry roads as much as possible when driving. If necessary, turning off high-power electrical appliances such as the air conditioning, or adjusting the A/C temperature to reduce the power consumed by high-power electrical appliances and to increase the driving range. Deep discharge will reduce the battery service life, shallow charge and shallow discharge will extend the battery service life. In low temperature, the available power of the high-voltage battery pack may be reduced, and the available power will decrease with the drop of temperature; when the vehicle with high power level is charged in a low temperature environment, the power may jump to 100%.
- 4 Vehicle will be kept dry and cannot be placed in damp environment for long time such as parking place with ponding. If the vehicle is immersed in water or waded into the water, it shall be parked in dry place.
- 5 When the vehicle is not used for a long time (more than 7 days), it is recommended to keep the high-voltage battery pack power at 40% ~ 60% to prolong the service life of the high-voltage battery pack; do not allow the vehicle to be parked for more than 7 days with the high-voltage battery pack power below 20%, please charge immediately when the power is below 5%, and parking for more than 12h is strictly prohibited, otherwise there may be a risk of over discharge of the high-voltage battery pack; it is recommended to use the vehicle at least once a month, and a slow full charge must be conducted every 3 months for the high-voltage battery pack, and then have it discharged to 40% ~ 60%, otherwise it may cause the high-voltage battery pack over discharge, which will lead to lower battery performance, or even damage, the resulting vehicle failure and damage will not be covered by the warranty.
- 6 Do not disassemble the high-voltage battery pack and related components for repair without approval, otherwise our Service Dealer will not fulfill the warranty terms.
- 7 It is recommended that a slow full charge is conducted for the vehicle every week or every 2,000 kilometers, waiting for active charging stop when charging to 100% power (that is, not actively stop the charging, waiting until the charging pile charges the vehicle high-voltage battery pack to the cut-off voltage and automatically stops charging).
- 8 High voltage battery pack is easily damaged at chassis position through scraping and collision. Therefore, you shall timely contact our Service Dealer if the vehicle has driven on abnormal pavement to check whether the high voltage battery pack has deformation or not and whether enclosure has crack or not.
- 9 If the vehicle encounters collision and scraping in the utilization process, the vehicle will be timely checked by our Service Dealer to confirm whether the high-voltage battery pack has deformation or not and whether the enclosure has crack or not; if serious accident occurs, after accident

has been disposed, you shall contact our Service Dealer to transfer the vehicle to our Service Dealer for check.

- 10 After a serious vehicle accident, personnel in the vehicle need leave the vehicle as soon as possible and contact our Service Dealer for disposal at once.
- 11 If the vehicle body need be repaired or painted due to damaged in an accident, you must contact our Service Dealer to avoid manual damage or fire disaster of high-voltage battery pack and relevant operation can be conducted after dismantling the high-voltage battery pack.
- 12 when the vehicle is used for the first time or re-used after parking for a long time, the instrument displayed power may have deviations, a full charge needs to be conducted for the vehicle.
- 13 In high or low temperature, prolonged charging time and weakened power performance may occur for the high-voltage battery pack, which is a normal phenomenon.
- 14 he power performance of high-voltage battery pack will be reduced under low battery condition, and the vehicle feedback performance will be reduced under high battery condition.

Tires

 **DEFECTIVE TIRES ARE DANGEROUS! Do NOT drive your vehicle if any tire is excessively worn, damaged or inflated to an incorrect pressure.**

Frequently inspect the tires and sidewalls for any sign of distortion (bulges), cuts or wear. Gravels and other sharp objects should be removed with a suitable blunt tool. If neglected, they may work through the tire.

Tire pressure

 **Driving with incorrectly inflated tires can affect vehicle stability, increase rolling resistance, and cause rapid tire wear and possible permanent damage to the cords of the tire casing.**

Remember tire wear and inflation pressure regulations. It is the driver's responsibility to ensure that the tires meet these requirements.

Check the tire pressures weekly, including the spare tire, and adjust the tire pressure according to the requirements on the tire pressure identification at the front lower part of vehicle B-pillar. This Handbook introduces the correct tire pressure in cold condition, see "Wheel and tire" in General Technical Parameters section.

Maintenance and Service

The spare tire should be maintained at the highest recommended pressure and adjusted before use. Pressure should be checked with an accurate Tire Pressure Gauge when the tire is cold instead of decreasing the value under warm condition as the pressure will be higher than normal pressure due to temperature. Be sure to install the valve caps to prevent dirt entry into the valve mechanism.

A natural pressure loss will occur with time; any unusual pressure loss should be investigated and rectified.

Note: *Specified pressure applies to a cold tire, while the pressure of hot tire should be higher.*

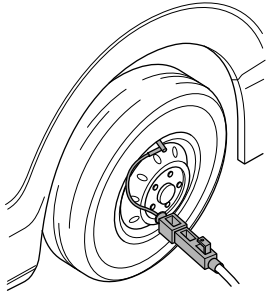

Wear indicator

There are wear indicators in the tread of all original tires. When the tire has worn down until 1.6 mm of the tread is remaining the wear indicators will appear across the full width of the tread pattern.

A tire should be replaced immediately where any part of the wear indicator becomes visible. However it is in your interest to note that tire safety and performance tends to reduce before the legal limit is reached. For example, badly worn tires will increase the risk of aquaplaning.

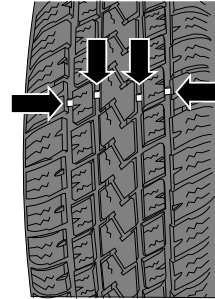

Tire check and rotation

In order to achieve even tire wear, it is recommended to check the tires every 5,000km, and check the wheel alignment parameters under the curb weight of the entire vehicle as required. If irregular wear is found, the tires position should be changed, and wheel alignment adjustments should be made if necessary. During the tire rotation, check the tires for correct dynamic balance.

During the tire rotation, check for uneven wear and damage. Abnormal wear is usually caused by incorrect tire pressure, poor wheel alignment, poor wheel dynamic balance, emergency braking or cornering. Check the tread or the side of the tire for collision damage or bulges. If one of these conditions is found, the tire shall be replaced. If fabric or cord is visible, the tire shall also be replaced. After the tire rotation, adjust the inflation pressure of the front and rear tires as shown on the tire pressure label on the vehicle and check the tightness of the wheel nuts.

Tire rotation method

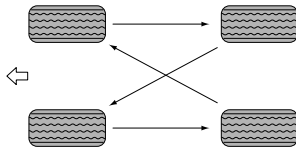

Other maintenance

Vehicle wash

! When driving for the first time after washing the vehicle, gently depress the brake pedal several times to remove moisture from the brake discs.

Carefully wash the tires. Never use a high pressure nozzle as it may damage tires. If any damage is found, replace the tire.

Water flushing is prohibited in the front part of the interior (near the dashboard area) to avoid unnecessary damage to related parts.

Do not flush the front compartment, battery compartment and peripheral inserts with water.

Careful attention to the following will help to retain the value of your vehicle:

- Clean the vehicle with cold or lukewarm water. Hot water may cause damage to vehicle paintwork under extreme cold conditions.
- No vehicle washing under strong direct sunlight during hot weather.

Maintenance and Service

- Use special vehicle cleaner to remove grease and tar spots on vehicle body and while still wet, wash the paintwork using a soft sponge and generous quantities of water containing car shampoo. Rinse thoroughly and dry off with a chamois leather.
- When cleaning the vehicle with a hose, it is prohibited to spray the water directly to the window, the door, or the brake parts through the gap of the wheel.
- After cleaning, inspect the paintwork for damage and stone chips; apply touch-up paint if necessary. Use polishing wax to protect the paintwork from time to time.
- When using high pressure cleaning equipments, the water jet shall be kept moving. Do not direct it at the door gaps, seals, electrical components or their connections.

Note: *Please timely remove the substances on the surface of the paint which seem harmless but in fact corrosive, such as bird droppings, resin, insect wreckage, tar spots, road salt and industrial dust. Otherwise permanent staining or damage will be produced.*

Seat and trim

Often use vacuum sweeper or soft brush to clean dirt and dust accumulated on fibers. Often use clean cloth to wipe the trim. Use special cleaner to remove general trim dust, staining or spots. Use special cleaner to clean leather parts.

Door seals

To prevent rubber door seals from freezing in a cold weather, a rubber maintenance product or a silicone spray shall be used for its protection.

Window glass

Often use glass cleaner to clean window glass.

Use high-quality cleaner or neutral detergent rather than abrasives or chemical solvents to wash.

Exterior trimming

Do not use chemical solvents to wipe, especially avoid using reagents containing benzene and naphtha solvents.

Anti-corrosion of vehicle

The main reasons for vehicle corrosion mainly have:

- Salt, sand, dust, ice and snow or chemicals, etc., are accumulated on underbody.
- Damage to the coating or other protective layers (such as paint damage, paint peeling, etc.) due to stone and gravel impact abrasion or minor accidents.
- Industrial pollution, excessive salt in the air in coastal areas, or excessive use of road de-icing salts can all accelerate the corrosion rate of the vehicle.
- If a vehicle or any part of it is exposed to a damp and high-temperature environment for a long time, it will also accelerate the corrosion of the vehicle.

Maintenance and Service

To properly protect against vehicle corrosion, the following rules shall be observed:

- Park your car in a well-ventilated and dry place. If conditions permit, indoor parking environment is recommended to avoid exposure to direct sunlight.
- Regularly wash your car using clean cold water and a neutral car detergent to maintain cleanliness.
- Periodically check the body paint for damage. If the surface paint layer is damaged or peeling off, repair the damaged area promptly to prevent corrosion once the metal is exposed. Paint repairs should be done at Our Service Dealer for standard restoration.
- If bird droppings, resin, insect carcasses, iron filings, cement, industrial dust, coal tar, gasoline, benzene, or other similar chemical substances adhere to the body surface, clean them as soon as possible.
- Regularly check the door drain holes to ensure that they are unobstructed and avoid corrosion caused by water accumulation.
- Prolonged accumulation of moisture, dust, mud, and sand under the carpet may cause vehicle corrosion. Regularly check the interior of the vehicle to ensure the area under the carpet is dry and clean.
- When transporting chemicals, detergents, fertilizers, salt, or other items, use appropriate dedicated containers. After transportation, wash the vehicle immediately and keep it dry (it is necessary to clean especially if there are spills or leaks).
- If you frequently drive on roads with de-icing salt, saline areas, near the beach, or on roads with coal tar, regularly check the underbody parts of your vehicle. Rinse off mud, snow, ice, salt stains, and other deposits from the underbody to reduce corrosion. Additional special protective measures are also recommended.
- If you often drive on gravel roads, consider installing mudguard behind the wheels.

General Technical Parameters

256 Major vehicle dimension parameters

257 Vehicle weight parameters

258 Dynamic performance parameters

259 Main parameters of drive motor

260 Chassis technical parameters

261 Recommended fluids

262 Wheels and tires

263 Wheel alignment parameters

General Technical Parameters

Major vehicle dimension parameters

Model	EKK1C-A000	EKK1C-A110
Driving type	4X2, RWD	4X4, 4WD
Length of outline dimension, mm	5500	5500
Width of outline dimension, mm	1997	1997
Height of outline dimension, mm	1860	1860
	1874(with luggage rack)	1874(with luggage rack)
Length of cargo bar board, mm	1561	1561
Width of cargo bar board, mm	1600	1600
	1500(with cargo box treasure)	1500(with cargo box treasure)
Height of cargo bar board, mm	535	535
Wheel base, mm	3300	3300
Front/Rear overhang, mm	953/1247	953/1247
Front/rear wheel track, mm	1685/1685	1685/1685
Minimum turning circle diameter, m	13.3	13.3

General Technical Parameters

Vehicle weight parameters

Model	EKK1C-A000	EKK1C-A110	EKK1C-A110
Maximum allowable total mass, kg	3500	3500	3500
Curb weight, kg	2750	2850	2880
Axle load (front/rear axle load under gross vehicle weight), kg	1425/2075	1510/1990	1550/1950
Number of seats	5	5	5

General Technical Parameters

Dynamic performance parameters

Item	Parameters	
Model	EKK1C-A000	EKK1C-A110
Maximum design speed, km/h	170	190
Maximum gradeability, %	30	50
Accelerating ability (Accelerating time from 0 to 100 km/h), second	9.2	5.9
Driving range (WLTP condition), km	450	430

General Technical Parameters

Main parameters of drive motor

Driving type	4X2, RWD	4X4, 4WD
Model of drive motor	TZ230XY1301	TZ180XS0951(Front drive motor) TZ230XY1301(Rear drive motor)
Type of drive motor	Permanent magnet synchronous motor	Permanent magnet synchronous motor
Maximum 30 minutes power	97kW@154.5Nm&6000rpm	54kW@64.5Nm&8000rpm(Front drive motor) 97kW@154.5Nm&6000rpm(Rear drive motor)
Maximum power	200kW@5000rpm	125kW@7000rpm(Front drive motor) 200kW@5000rpm(Rear drive motor)
Peak speed, r/min	17000	17000
Peak torque, Nm	450	250(Front drive motor) 450(Rear drive motor)
Working voltage of motor, V	328	328

General Technical Parameters

Chassis technical parameters

Item	Parameters
Front suspension	Double wishbone independent suspension / Air suspension
Rear suspension	Multi link independent suspension / Air suspension
Requirements for steel wheel dynamic balance	Residual dynamic unbalance on both sides of steel wheel assembly is less than 10g
Requirements for aluminum wheel dynamic balance	Residual dynamic unbalance on both sides of aluminum wheel assembly is less than 8g
Reasonable free travel range of brake pedal	Within 20mm
Reasonable application range of brake friction pair	For single friction plate, the friction material shall remain at least 2mm The wear on each side of the brake disc shall be less than 1mm

General Technical Parameters

Recommended fluids

Item	Grade	Capacity
Coolant (electric drive system), L	D-35(-35°C)	14.3
Brake fluid, L	aika 901-4 DOT 4	0.8
Washer fluid, L	Universal low freezing point washer fluid	3.7
Air conditioning refrigerant, g	R-1234yf / HFC-1234yf (CF ₃ CF=CH ₂) GWP=0.501	760
Front reducer lubricating fluid, L	Shell SL2808	0.95±0.05
Rear reducer lubricating fluid, L	Shell SL2808	1.8±0.05

General Technical Parameters

Wheels and tires

Item			Parameters			
Wheel specification			8.5Jx20		8Jx18	
Tire specifications			275/55R20		265/65R18	
Tire pressure (cold state)	Front wheel	Half load	260kPa/2.6bar/38psi		260kPa/2.6bar/38psi	
		Full load	260kPa/2.6bar/38psi		260kPa/2.6bar/38psi	
	Rear wheel	Half load	260kPa/2.6bar/38psi		260kPa/2.6bar/38psi	
		Full load	260kPa/2.6bar/38psi		260kPa/2.6bar/38psi	
Spare wheel specification			275/55R20	255/60R18	265/65R18	255/60R18
Tire pressure of spare wheel(cold condition)			290kPa/2.9bar/42psi		290kPa/2.9bar/42psi	
Wheel nut torque			180±18N·m			

General Technical Parameters

Wheel alignment parameters

Item		Parameters
Front suspension	Toe-in (single side)	0.1°±0.083° 0.15°±0.10°(It applies to vehicles with long-term full load)
	Camber	-0.083°±0.75° Difference between left and right ≤0.75°
	Kingpin inclination angle	6.8°
	Kingpin caster angle	3.8°±0.75° Difference between left and right ≤0.75°
Rear suspension	Toe-in (single side)	0°±0.05°(It applies to vehicles with air suspension) -0.117°±0.05°(It applies to vehicles without air suspension)
	Camber	0°±0.75°(It applies to vehicles with air suspension) 0.3°±0.75°(It applies to vehicles without air suspension) Difference between left and right ≤0.75°
	Thrust angle	0°±0.15°